



**KENTUCKY DEPARTMENT OF EDUCATION  
2023 BLUE BIRD SCHOOL BUS PURCHASE AUTHORIZATION**

The Board of Education \_\_\_\_\_, Kentucky, on \_\_\_\_\_, 20\_\_\_\_, in a legally called and constituted meeting, did vote to purchase school buses through the Kentucky State Contract price procedure.

This Board of Education took this official action in order to authorize the Chief State School Officer to procure 2023 school buses. This action, as spread upon the minutes of the meeting of this Board of Education on the above date, should be construed as evidence of obligation of this Board of Education to purchase the above school buses through State Price Contract agreements established in accordance with statutory authority.

Signed  
\_\_\_\_\_, Secretary  
\_\_\_\_\_, Superintendent  
Of \_\_\_\_\_, Board of Education  
Date \_\_\_\_\_.

**BODY SIDE NUMBERS:** Indicate the body side number the Board of Education wants painted on the body side of each school bus. Match body side number to individual item numbers. Example: Item 1 - Side number - 5, 6, 7, 8

---



---



---



---

**DUE TO SUPPLY CHAIN ISSUES, CURRENT LEAD TIMES FOR BUS COMPLETION IS 240-270 DAYS**

ATTACH ADDITIONAL INFORMATION IF NECESSARY

All Blue Bird Type A buses are Hydraulic Brakes and have a left side center fuel tank. All Blue Bird Type C have Center Rear fuel tanks.

**Special Needs Diesel**

Item #	Quantity	Bus Type	Capacity	Engine	Chassis	HP	Transmission	Wheel Base	Rear Axle Overhang	Base Price
BB1		C	22	Cummins	Blue Bird	220	Allison 2500	189	125	\$122,850
BB2		C	23	Cummins	Blue Bird	220	Allison 2500	217	132	\$122,270
BB3		C	28	Cummins	Blue Bird	220	Allison 2500	273	153	\$126,550
BB4		C	28	Cummins	Blue Bird	250	Allison 3000	273	153	\$133,830

**Special Needs Propane**

Item #	Quantity	Bus Type	Capacity	Engine	Chassis	HP	Transmission	Wheel Base	Rear Axle Overhang	Base Price
BB5		A	8+2	Ford	Blue Bird	262	Ford	158	91	\$127,190
BB6		C	22	Ford	Blue Bird	320	Ford	189	125	\$129,480
BB7		C	23	Ford	Blue Bird	320	Ford	217	132	\$131,080
BB8		C	28	Ford	Blue Bird	320	Ford	273	153	\$136,590
BB9		C	28 EXT	Ford	Blue Bird	320	Ford	273	153	\$138,160

**Special Needs Electric**

Item #	Quantity	Bus Type	Capacity	Engine	Chassis	HP	Transmission	Wheel Base	Rear Axle Overhang	Base Price
BB10		A	8+2	Borg-Warner	Blue Bird	Elect	Electric	158	91	\$299,790

**Type A/C – Diesel**

Blue Bird Type A diesel has a left side middle fuel tank. All others have center rear fuel tank.

Item #	Quantity	Bus Type	Capacity	Engine Manufacturer	Chassis Manufacturer	HP	Transmission Manufacturer	Wheel Base	Rear Axle Overhang	Base Price
BB11		C	34	Cummins	Blue Bird	220	Allison 2500	169	125	\$111,590
BB12		C	34	Cummins	Blue Bird	220	Allison 2500	189	125	\$113,120
BB13		C	52	Cummins	Blue Bird	220	Allison 2500	217	132	\$115,000
BB14		C	66	Cummins	Blue Bird	220	Allison 2500	273	153	\$119,280
BB15		C	66	Cummins	Blue Bird	250	Allison 3000	273	153	\$126,570
BB16		C	72	Cummins	Blue Bird	220	Allison 2500	273	160	\$120,790
BB17		C	72	Cummins	Blue Bird	250	Allison 3000	273	160	\$128,070
BB18		C	75	Cummins	Blue Bird	250	Allison 3000	280	174	\$132,000

All Blue Bird Type A buses are Hydraulic Brakes and have a left side center fuel tank. All Blue Bird Type C have Center Rear fuel tanks.

**Type A/C Propane**

Item #	Quantity	Bus Type	Capacity	Engine	Chassis	HP	Transmission	Wheel Base	Rear Axle Overhang	Base Price
BB19		A	22	Ford	Blue Bird	362	Ford	158	91	\$119,790
BB20		C	34	Ford	Blue Bird	320	Ford	189	125	\$119,570
BB21		C	52	Ford	Blue Bird	320	Ford	217	132	\$123,500
BB22		C	66	Ford	Blue Bird	320	Ford	273	139	\$128,820
BB23		C	72	Ford	Blue Bird	320	Ford	273	160	\$130,420
BB24		C	72 EXT	Ford	Blue Bird	320	Ford	273	160	\$132,780
BB25		C	75	Ford	Blue Bird	320	Ford	280	174	\$135,890

**Type A/C Electric**

Item #	Quantity	Bus Type	Capacity	Engine	Chassis	HP	Transmission	Wheel Base	Rear Axle Overhang	Base Price
BB26		A	22	Borg-Warner	Blue Bird	Elect	Electric	158	91	\$299,970
BB27		C	72	Cummins	Blue Bird	Elect	Electric	273	160	\$389,390

**Type D Diesel**

Item #	Quantity	Bus Type	Capacity	Engine	Chassis	HP	Transmission	Wheel Base	Rear Axle Overhang	Base Price
BB28		D/RE	72	Cummins	Blue Bird	250	Allison 3000	245	121	\$148,020
BB29		D/RE	78	Cummins	Blue Bird	250	Allison 3000	273	122	\$149,800
BB30		D/FE	70	Cummins	Blue Bird	250	Allison 3000	232	153	\$140,650
BB31		D/FE	74	Cummins	Blue Bird	250	Allison 3000	232	153	\$141,790
BB32		D/FE	78	Cummins	Blue Bird	250	Allison 3000	232	153	\$141,730

**Type D Electric**

Item #	Quantity	Bus Type	Capacity	Engine	Chassis	HP	Transmission	Wheel Base	Rear Axle Overhang	Base Price
BB33		D/RE	78	Cummins	Blue Bird	Elect	Electric	273	122	\$404,200

**RADIO**

Option	Bus Type	Option	Extended Description	Price
BBO1	ALL	Radio	Radio, AM/FM/PA	\$725
BBO2	ALL	Radio	Radio, AM/FM/PA (w/ external speaker)	\$775

**CAMERAS**

Option	Bus Type	Option	Extended Description	Price
BBO3	ALL	Camera	REI- 6 channel DVR-HD5-600 w/ 1 camera and 500 GB Hard Drive (includes install)	\$1950
BBO4	ALL	Camera	REI- 1 TB Hard Drive Upgrade	\$300
BBO5	ALL	Camera	REI- Additional Camera Head (includes install)	\$350
BBO6	ALL	Camera	REI- Installation Cost for customer supplied single camera system	\$600
BBO7	ALL	Camera	REI- GPS Sensor (for speed) (includes install)	\$150
BBO8	ALL	Camera	REI- Inertial Sensor (includes install)	\$150
BBO9	ALL	Camera	REI- 500 GB Hard Drive (Spare)	\$450
BBO10	ALL	Camera	REI- 1 TB Hard Drive (Spare)	\$550
BBO11	ALL	Camera	REI- Stop Arm Camera (includes install)	\$500
BBO12	ALL	Camera	REI- In Bus Video System Lock Box	\$175
BBO13	ALL	Camera	REI- LCD Monitor Kit 5.6" (battery, charger and case)	\$250
BBO14	ALL	Camera	REI- Installation Cost for each additional camera head	\$200
BBO15	ALL	Camera	REI- Event Market, cable and panic button (includes install)	\$150
BBO16	ALL	Camera	Perimeter View 360 Degree Camera (see sales rep for installation cost)	\$2400

**LUGGAGE (see chart for compatibility)**

Option	Bus Type	Option	Extended Description	Price
BBO17	C, D/RE, D/FE	Luggage	14.5 Cu Ft Left Hand Overhang	\$1150
BBO18	C, D/RE, D/FE	Luggage	20.7 Cu Ft Left Hand Overhang	\$1,675
BBO19	C, D/RE, D/FE	Luggage	16 Cu Ft Left Hand Mid Mount	\$875
BBO20	C, D/RE, D/FE	Luggage	22.7 Cu Ft Left Hand Mid Mount	\$1300
BBO21	C, D/RE, D/FE	Luggage	28.4 Cu Ft Left Hand Mid Mount	\$1,400
BBO22	C, D/RE, D/FE	Luggage	14.5 Cu Ft Right Hand Overhang	\$1,150
BBO23	C, D/RE, D/FE	Luggage	16 Cu Ft Right Hand Overhang	\$875
BBO24	C, D/RE, D/FE	Luggage	20.7 Cu Ft Right Hand Overhang	\$1,675
BBO25	C, D/RE, D/FE	Luggage	22.7 Cu Ft Right Hand Overhang	\$1300
BBO26	C, D/RE, D/FE	Luggage	16 Cu Ft Right Hand Mid Mount	\$875
BBO27	C, D/RE, D/FE	Luggage	22.7 Cu Ft Right Hand Mid Mount	\$1300
BBO28	C, D/RE, D/FE	Luggage	28.4 Cu Ft Right Hand Mid Mount	\$1,400
BBO29	D/RE	Luggage	122 Cu Ft Pass Through	\$5,750
BBO30	C, D/RE, D/FE	Luggage	Gas Shock (single door)	\$125
BBO31	C, D/RE, D/FE	Luggage	Gas Shock (dual door)	\$250

**AIR CONDITIONING (A/C)**

Option	Bus Type	Option	Extended Description	Price
BBO32	A	A/C	Type A Air Conditioning	\$6,000
BBO33	C	A/C	Type C- 95,000 BTU; Skirt Mounted (34 Pax)	\$10,500
BBO34	C	A/C	Type C- 110,000 BTU; Skirt Mounted (52-66 Pax)	\$10,700
BBO35	C	A/C	Type C- 126,000 BTU; Skirt Mounted (70-75 Pax)	\$10,900
BBO36	C	A/C	Type C- 126,000 BTU; Roof Mounted	\$11,750
BBO37	D/RE, D/FE	A/C	Type D- 136,000 BTU; Roof Mounted	\$13,500
BBO38	D/RE, D/FE	A/C	Type D- 126,000 BTU; Skirt Mounted	\$11,500

**TIRES**

Option	Bus Type	Option	Extended Description	Price
BBO39	C	Tires	LRH in lieu of LRG Tires	\$1000
BBO40	C	Tires	LRH in lieu of LRG Tires	\$1000

**HORSE POWER UPGRADE**

Option	Bus Type	Option	Extended Description	Price
BBO41	C	HP Upgrade	200-HP Cummins Engine (deduction) on Type C Buses (34-52P Shell)	-\$450
BBO42	C	HP Upgrade	250-HP Cummins Engine with Allison 2500	\$2,750
BBO43	D/FE	HP Upgrade	260-HP Cummins Engine with Allison 3000	\$600
BBO44	D/RE	HP Upgrade	280-HP Cummins Engine with Allison 3000	\$2,750
BBO45	C	HP Upgrade	240-HP Cummins Engine with Allison 2500	\$600

**SEATING**

Option	Bus Type	Option	Extended Description	Price
BBO46	ALL	Seating	(1) 39" CE White Child Safety Restraint Seat in lieu of Standard 39" HB Seat	\$875
BBO47	ALL	Seating	(1) 30" CE White Child Safety Restraint Seat in lieu of Standard 30" HB Seat	\$800
BBO48	C	Seating	(1) Track Mounted Barrier	\$300
BBO49	C	Seating	(1) 30" Track Mounted Seat w/Lap and Shoulder Belts	\$650
BBO50	C	Seating	(1) additional W/C position	\$850
BBO51	C	Seating	Delete (1) W/C Position and add (2) standard HB Seats	\$400

**OTHER OPTIONS**

Option	Bus Type	Option	Extended Description	Price
BBO52	C, D/RE, D/FE	Brakes	Air Disc Brakes	\$1,750
BBO53	C, D/RE, D/FE	Tinting	Light Transmittance Tinted Windows	\$600
BBO54	C, D/RE, D/FE	Heater	Espar Series Heater (includes 7 day timer)	\$1850
BBO55	C, D/RE, D/FE	Ceiling	Full Length Perforated Ceiling	\$950
BBO56	C	Pedals	Adjustable Pedals	\$1250
BBO57	C	Axles	23.5k Rear Axle Upgrade (may be required w/100 gallon tank or certain luggage configurations)	\$1000
BBO58	C, D/RE, D/FE	Arm Rest	Console Mounted Driver Left Hand Armrest	\$50
BBO59	C, D/RE, D/FE	Glove Box	In Dash Glove Box	\$100
BBO60	C, D/RE, D/FE	Cruise	Cruise Control	\$50
BBO61	C, D/RE, D/FE	Trash Can	Trash Can	\$75
BBO62	C, D/RE, D/FE	Mirrors	Rosco Breakaway Mirrors	\$225
BBO63	C	Fuel Tank	100-gallon diesel tank	\$650
BBO64	C, D/RE, D/FE	Mud Flaps	Blue Bird Logo Rear Mudflaps	\$100

## 2022 - 2023 School Bus Luggage Compartment Options

LUGGAGE OPTIONS													
BLUE BIRD LUGGAGE COMPARTMENT OPTIONS & COMPATIBILITY													
LOCATION	LHOH	LHOH	LHMM	LHMM	LHMM	RHOH	RHOH	RHOH	RHOH	RHMM	RHMM	RHMM	Pass Thru
SIZE	14.5 CuFt	20.7 CuFt	16 CuFt	22.7 CuFt	28.4 CuFt	14.5 CuFt	16 CuFt	20.7 CuFt	22.7 CuFt	16 CuFt	22.7 CuFt	28.4 CuFt	122 CuFt
<b>CAPACITY/MODEL</b>													
34/1910 Vision	N/A	N/A	N/A	N/A	N/A	N/A	N/A	N/A	N/A	N/A	N/A	N/A	N/A
34/2311 Vision	\$1,150	N/A	\$875	N/A	N/A	N/A	N/A	N/A	N/A	\$875	N/A	N/A	N/A
52/2610 Vision	\$1,150	N/A	\$875	\$1,300	N/A	N/A	\$875	N/A	N/A	\$875	\$1,300	N/A	N/A
66/3201 Vision	\$1,150	N/A	\$875	\$1,300	N/A	\$1,150	\$875	\$1,675	N/A	\$875	\$1,300	\$1,400	N/A
72/3310 Vision	\$1,150	\$1,675	\$875	\$1,300	\$1,400	\$1,150	\$875	N/A	N/A	\$875	\$1,300	\$1,400	N/A
22/2311 Vision	\$1,150	N/A	\$875	N/A	N/A	\$1,150	N/A	N/A	N/A	N/A	N/A	N/A	N/A
23/2610 Vision	\$1,150	N/A	\$875	\$1,300	N/A	\$1,150	\$875	N/A	N/A	N/A	N/A	N/A	N/A
28/3303 Vision	\$1,150	\$1,675	\$875	\$1,300	\$1,400	\$1,150	\$875	\$1,675	N/A	N/A	N/A	N/A	N/A
70/3909 FE	\$1,150	\$1,675	N/A	N/A	N/A	N/A	\$875	\$1,675	\$1,300	\$875	\$1,300	\$1,400	N/A
74/3909 FE	\$1,150	\$1,675	N/A	N/A	N/A	N/A	\$875	\$1,675	\$1,300	\$875	\$1,300	\$1,400	N/A
78/4004 FE	\$1,150	\$1,675	\$875	\$1,300	\$1,400	N/A	\$875	\$1,675	\$1,300	\$875	\$1,300	\$1,400	N/A
78/4006 RE	N/A	N/A	\$875	\$1,300	\$1,400	N/A	N/A	N/A	N/A	\$875	\$1,300	\$1,400	\$5,750

LHOH - Left hand overhang behind rear axle LHMM - Left hand midmount between axles RHOH - Right hand overhang behind rear axle RHMM - Right hand midmount between axles

\*All luggage boxes are subject to engineering approval

\*Some luggage options may require that the triangle box be moved or deleted

# Blue Bird Floor Plans 2023

## Contact Information

	Phone	Email
Mark Parsons - KY General Manager	866-376-1644	<a href="mailto:mparsons@centralstatesbus.com">mparsons@centralstatesbus.com</a>
Chuck Harvill - General Manager	877-307-0322	<a href="mailto:charvill@centralstatesbus.com">charvill@centralstatesbus.com</a>
Jeff Reitz - President/CEO	800-825-8273	<a href="mailto:jreitz@centralstatesbus.com">jreitz@centralstatesbus.com</a>





**BLUE BIRD**

Quote Id: 213589      Body Plan / Seat Plan Information

Body Plan: 5014601

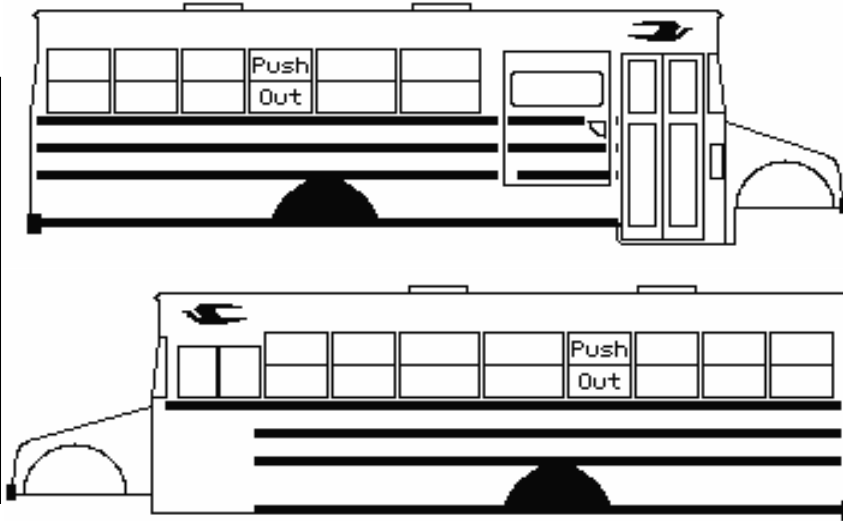

**AT A GLANCE**

**ENGINE-** Cummins  
**FUEL TYPE-** Diesel  
**HP-** 220  
**TRANS-** Allison  
**SIZE-** 2311  
**CAP-** 22  
**WHEELBASE -** 189"  
**ITEM #**BB1

Seat Plan: 27937

SP: 27937 BBCV 2311, 22 CAP

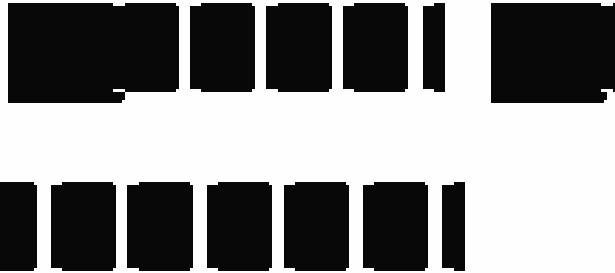

Quote Id: 213589      Seat Plan Spacing Chart

SP: 27937 BBCV 2311, 22 CAP

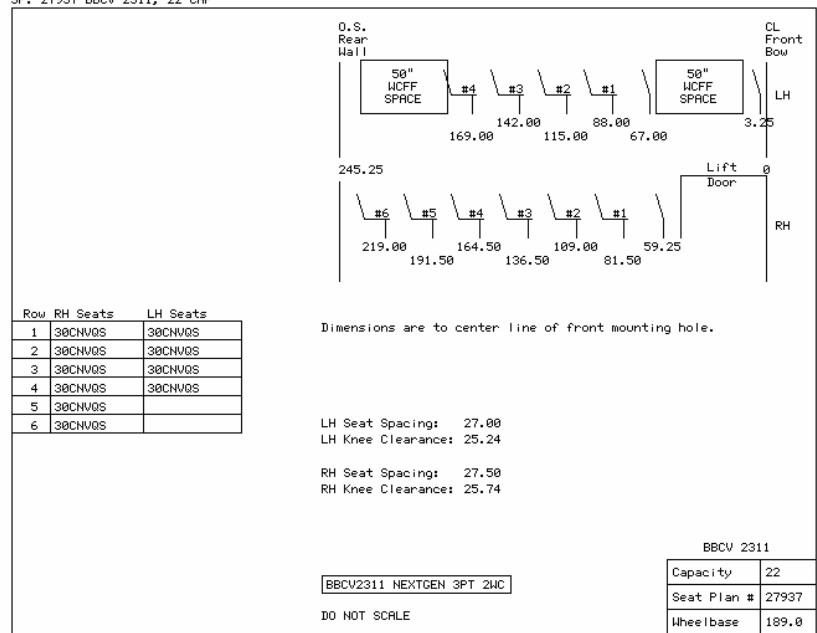

Quote Id: 213590      Body Plan / Seat Plan Information

Body Plan: 5014629

**AT A GLANCE**

**ENGINE-** Cummins ISB  
**FUEL TYPE-** Diesel  
**HP-** 220  
**TRANS-** Allison  
**SIZE-** 2610  
**CAP-** 23  
**WHEELBASE -** 217"  
**ITEM #**BB2

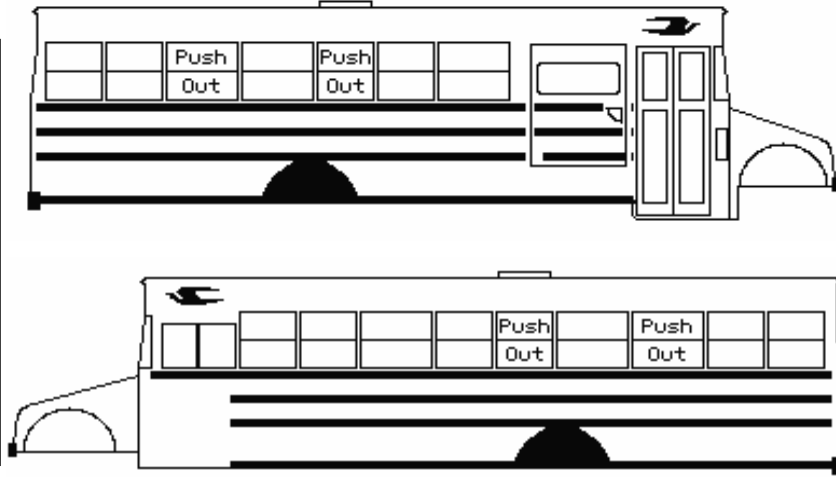

Seat Plan: 27130

SP: 27130 BBCV 2610, 23 CAP



Quote Id: 213590      Seat Plan Spacing Chart

SP: 27130 BBCV 2610, 23 CAP

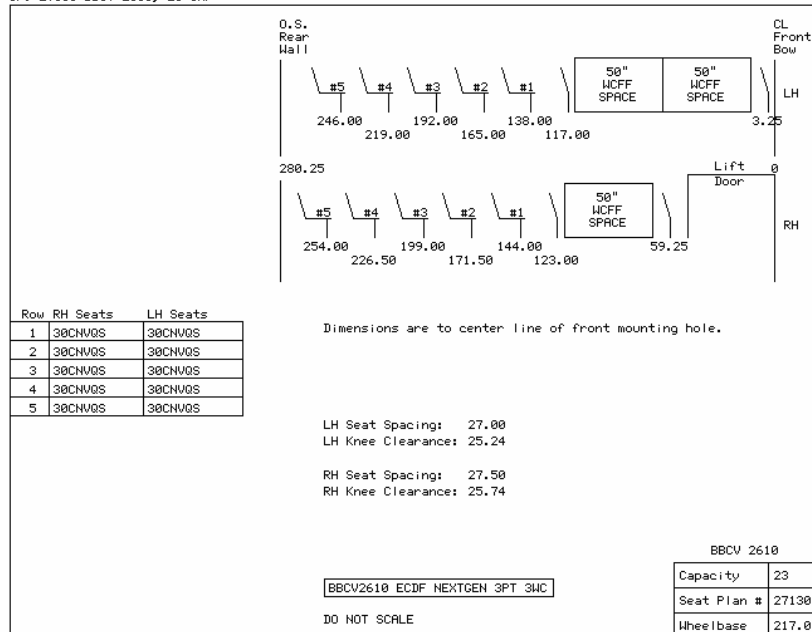



Quote Id: 213591 | Body Plan / Seat Plan Information

Body Plan: 5014628

**AT A GLANCE**

**ENGINE-** Cummins ISB  
**FUEL TYPE-** Diesel  
**HP-** 220  
**TRANS-** Allison  
**SIZE-** 3303  
**CAP-** 28  
**WHEELBASE -** 273"  
**ITEM #**BB3

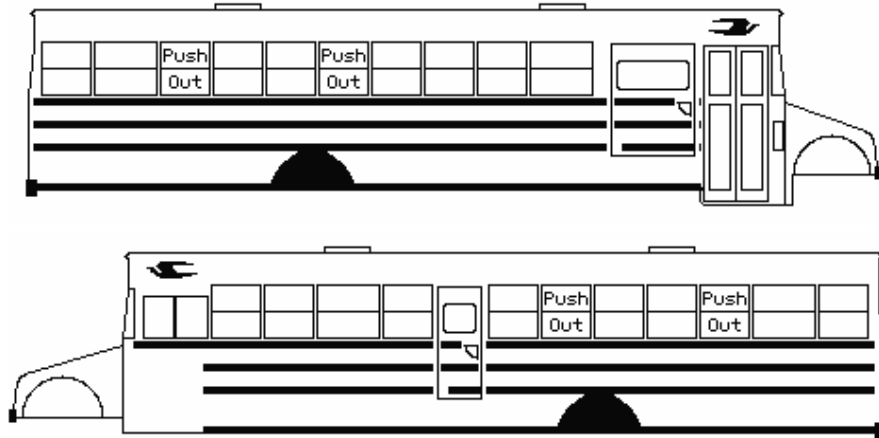

Seat Plan: 29268

SP: 29268 BBCV 3303, 28 CAP



Quote Id: 213591 | Seat Plan Spacing Chart

SP: 29268 BBCV 3303, 28 CAP

Row	RH Seats	LH Seats
1	30CNVQS	30CNVQS
2	30CNVQS	30CNVQS
3	30CNVQS	30CNVQS
4	30CNVQS	30CNVQS
5	30CNVQS	30CNVQS
6	30CNVQS	30CNVQS

Dimensions are to center line of front mounting hole.

LH Seat Spacing: 28.50  
 LH Knee Clearance: 26.74

RH Seat Spacing: 27.25  
 RH Knee Clearance: 25.49

BBCV 3303

BBCV3303 ECDF SED5L NEXTGEN 3PT 4WC	Capacity	28
	Seat Plan #	29268
	Wheelbase	273.0

DO NOT SCALE

Quote Id: 213592      Body Plan / Seat Plan Information

Body Plan: 5014628

**AT A GLANCE**

**ENGINE-** Cummins ISB  
**FUEL TYPE-** Diesel  
**HP-** 250  
**TRANS-** Allison  
**SIZE-** 3303  
**CAP-** 28  
**WHEELBASE -** 273"  
**ITEM #**BB4

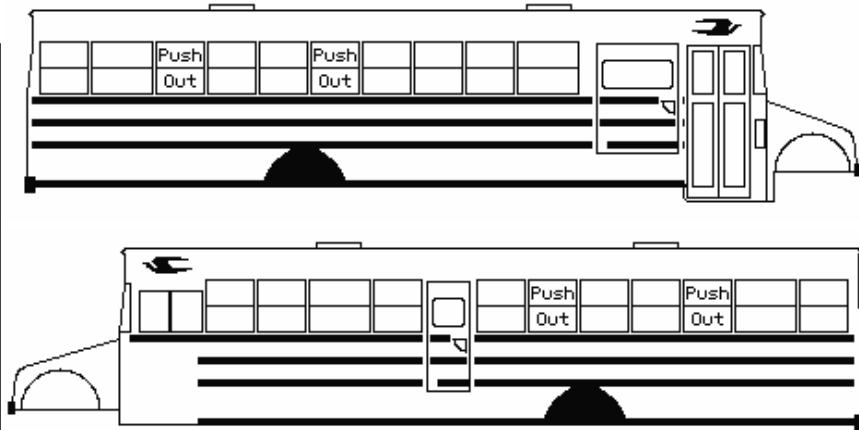

Seat Plan: 29268

SP: 29268 BBCV 3303, 28 CAP



Quote Id: 213592      Seat Plan Spacing Chart

SP: 29268 BBCV 3303, 28 CAP

Row	RH Seats	LH Seats
1	30CNVQS	30CNVQS
2	30CNVQS	30CNVQS
3	30CNVQS	30CNVQS
4	30CNVQS	30CNVQS
5	30CNVQS	30CNVQS
6	30CNVQS	30CNVQS

Dimensions are to center line of front mounting hole.

LH Seat Spacing: 28.50  
 LH Knee Clearance: 26.74  
 RH Seat Spacing: 27.25  
 RH Knee Clearance: 25.49

BBCV 3303

BBCV3303 ECDF SED5L NEXTGEN 3PT 4HC	Capacity	28
	Seat Plan #	29268
	Wheelbase	273.0

DO NOT SCALE

NOTE: The wheelchair restraint configuration for this bus is as shown below:

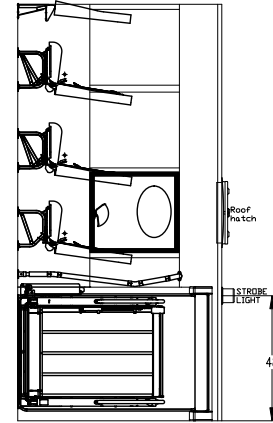
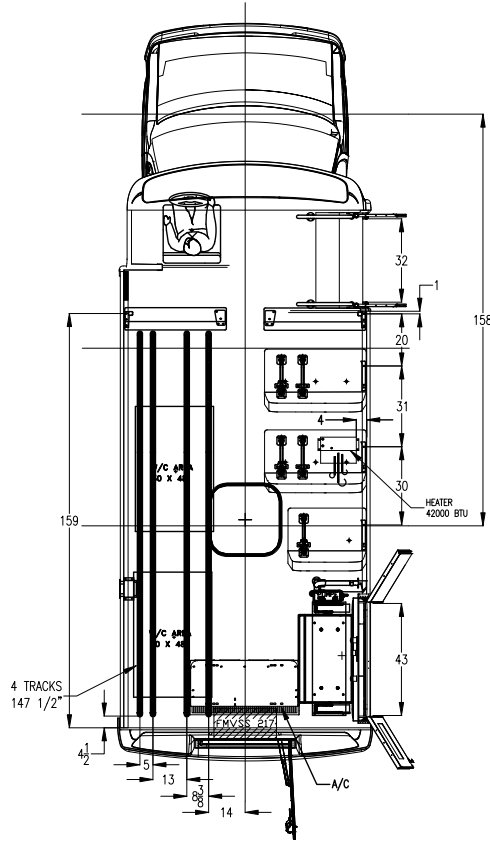
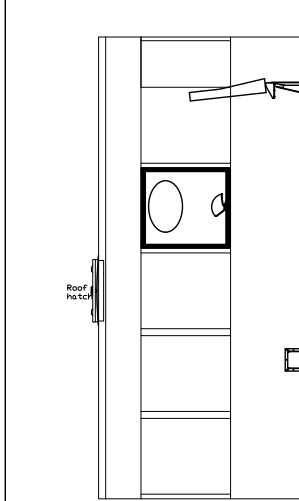
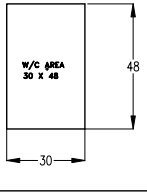

**AT A GLANCE**

**BODY-** Micro Bird  
**ENGINE-** Ford  
**FUEL TYPE-** Propane  
**HP-** 262  
**TRANS-** Ford  
**CAP-** 8+2  
**WHEELBASE -** 158"  
**ITEM #BB5**

SEAT	DIM.	SIDE	QTY
S3	39	RH	2
S3	30	RH	1

Seat spacing = See drawing      D.O.D.: 32"

APPROVED CONFIGURATIONS

Total ambulatory passengers :	8	Total wheel chair passengers :	2
Load cap. (pass. + cargo) :		**kg	**lbs

2021/05/27	LR	CREATION DRAWING	Drawn by : LINE ROY	
REV. YYY/MM/DD	BY	DESCRIPTION	MODEL: UFH5 CRH WSS	
Stock Number:			UNIT = INCHES	Drawing no.
Customer Approval:			SCALE = DO NOT SCALE	053307
Date:			NOTE: Any option added to this floorplan shall be approved by the Corporation Micro Bird Inc. technical department.	

Quote Id: 213601      Body Plan / Seat Plan Information

Body Plan: 5014601

**AT A GLANCE**

**ENGINE-** Ford  
**FUEL TYPE-** Propane  
**HP-** 320  
**TRANS-** Ford  
**SIZE-** 2311  
**CAP-** 22  
**WHEELBASE -** 189"  
**ITEM #**BB6

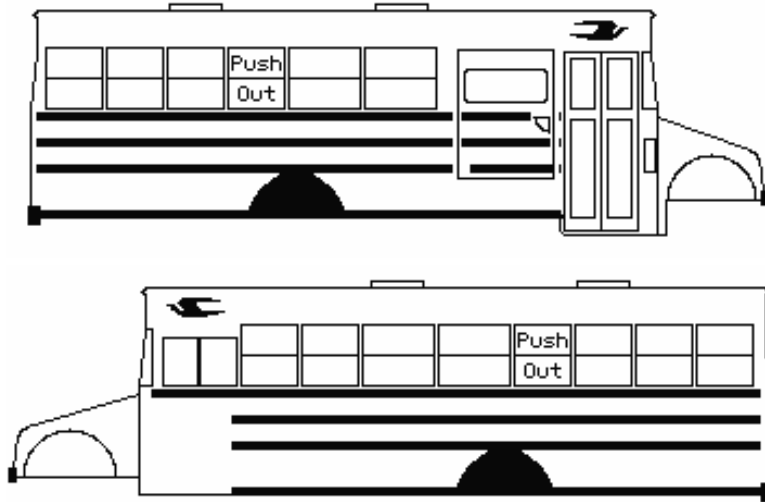

Seat Plan: 27937

SP: 27937 BBCV 2311, 22 CAP



Quote Id: 213601      Seat Plan Spacing Chart

SP: 27937 BBCV 2311, 22 CAP

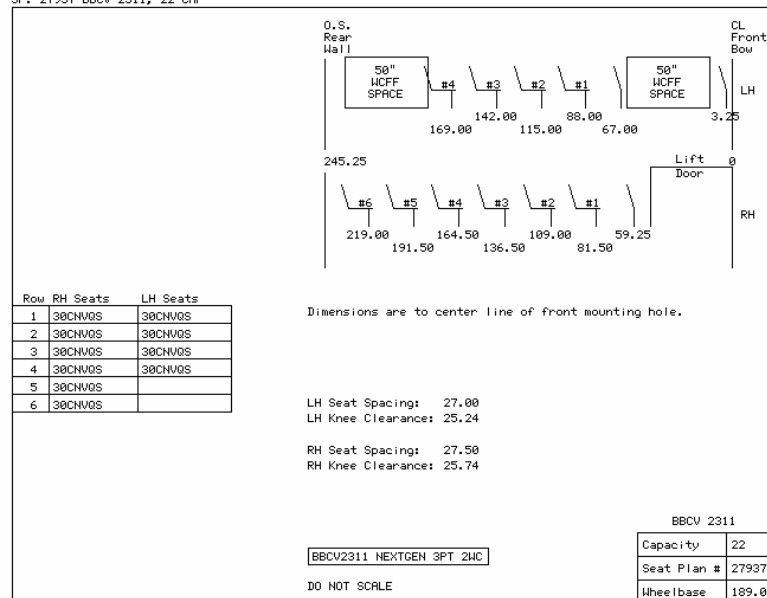



Quote Id: 213602      Body Plan / Seat Plan Information

Body Plan: 5014629

**AT A GLANCE**

**ENGINE-** Ford  
**FUEL TYPE-** Propane  
**HP-** 320  
**TRANS-** Ford  
**SIZE-** 2610  
**CAP-** 23  
**WHEELBASE -** 217"  
**ITEM #**BB7

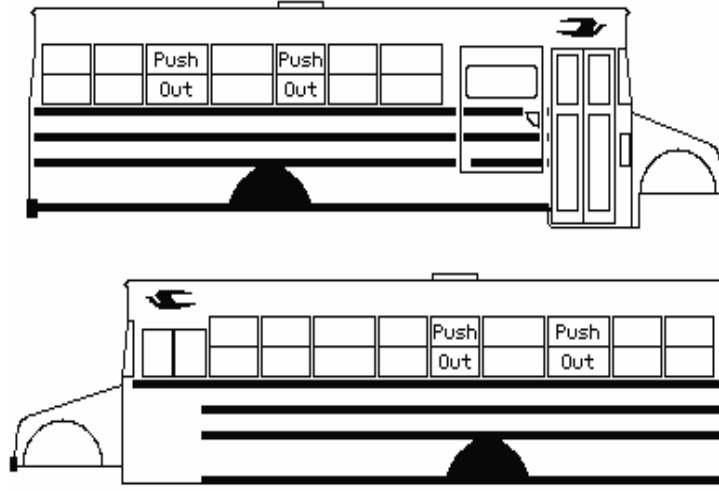

Seat Plan: 27130

SP: 27130 BBCV 2610, 23 CAP



Quote Id: 213602      Seat Plan Spacing Chart

SP: 27130 BBCV 2610, 23 CAP

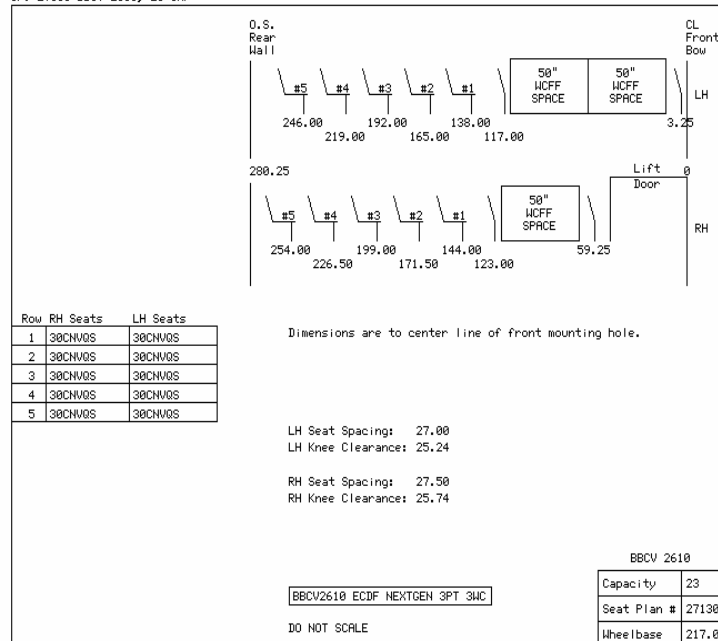



Quote Id: 213603      Body Plan / Seat Plan Information

Body Plan: 5014628

**AT A GLANCE**

**ENGINE-** Ford  
**FUEL TYPE-** Propane  
**HP-** 320  
**TRANS-** Ford  
**SIZE-** 3303  
**CAP-** 28  
**WHEELBASE -** 273"  
**ITEM #**BB8

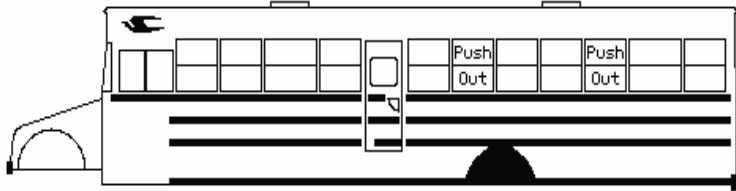
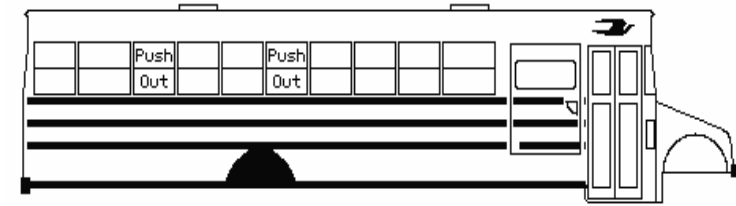

Seat Plan: 29268

SP: 29268 BBCV 3303, 28 CAP



Quote Id: 213603      Seat Plan Spacing Chart

SP: 29268 BBCV 3303, 28 CAP

O.S. Rear Wall      Emergency Door      CL Front Bow

LH

RH

Lift Door

50" WCFF SPACE      50" WCFF SPACE

50" WCFF SPACE      50" WCFF SPACE

Row	RH Seats	LH Seats
1	30CNVGS	30CNVGS
2	30CNVGS	30CNVGS
3	30CNVGS	30CNVGS
4	30CNVGS	30CNVGS
5	30CNVGS	30CNVGS
6	30CNVGS	30CNVGS

Dimensions are to center line of front mounting hole.

LH Seat Spacing: 28.50  
 LH Knee Clearance: 26.74

RH Seat Spacing: 27.25  
 RH Knee Clearance: 25.49

BBCV 3303

BBCV3303 EDCF SED5L NEXTGEN 3PT 4HC	Capacity	28
	Seat Plan #	29268
	Wheelbase	273.0

DO NOT SCALE





**BLUE BIRD**

Quote Id: 213604      Body Plan / Seat Plan Information

Body Plan: 5014628

## AT A GLANCE

**ENGINE-** Ford  
**FUEL TYPE-** Propane  
**HP-** 320  
**TRANS-** Ford  
**SIZE-** 3303  
**CAP-** 28 EXT  
**WHEELBASE -** 273"  
**ITEM #**BB9

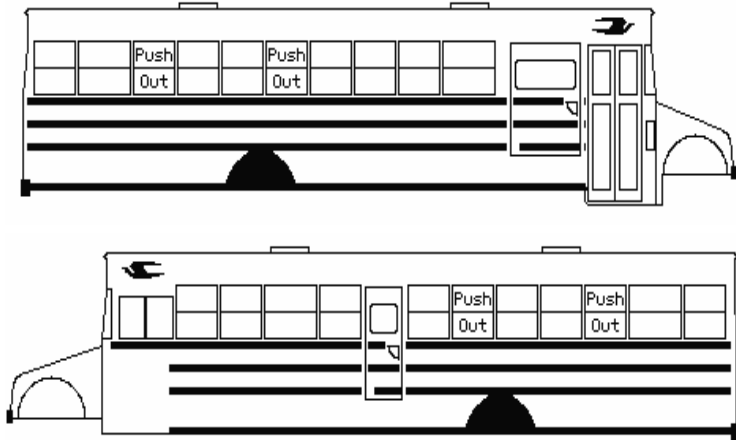

Seat Plan: 29268

SP: 29268 BBCV 3303, 28 CAP



Quote Id: 213604      Seat Plan Spacing Chart

SP: 29268 BBCV 3303, 28 CAP

Row	RH Seats	LH Seats
1	30CNV0S	30CNV0S
2	30CNV0S	30CNV0S
3	30CNV0S	30CNV0S
4	30CNV0S	30CNV0S
5	30CNV0S	30CNV0S
6	30CNV0S	30CNV0S

Dimensions are to center line of front mounting hole.

LH Seat Spacing: 28.50  
 LH Knee Clearance: 26.74

RH Seat Spacing: 27.25  
 RH Knee Clearance: 25.49

BBCV 3303	
Capacity	28
Seat Plan #	29268
Wheelbase	273.0

BBCV3303 EDCF SED5L NEXTGEN 3PT 4NC

DO NOT SCALE

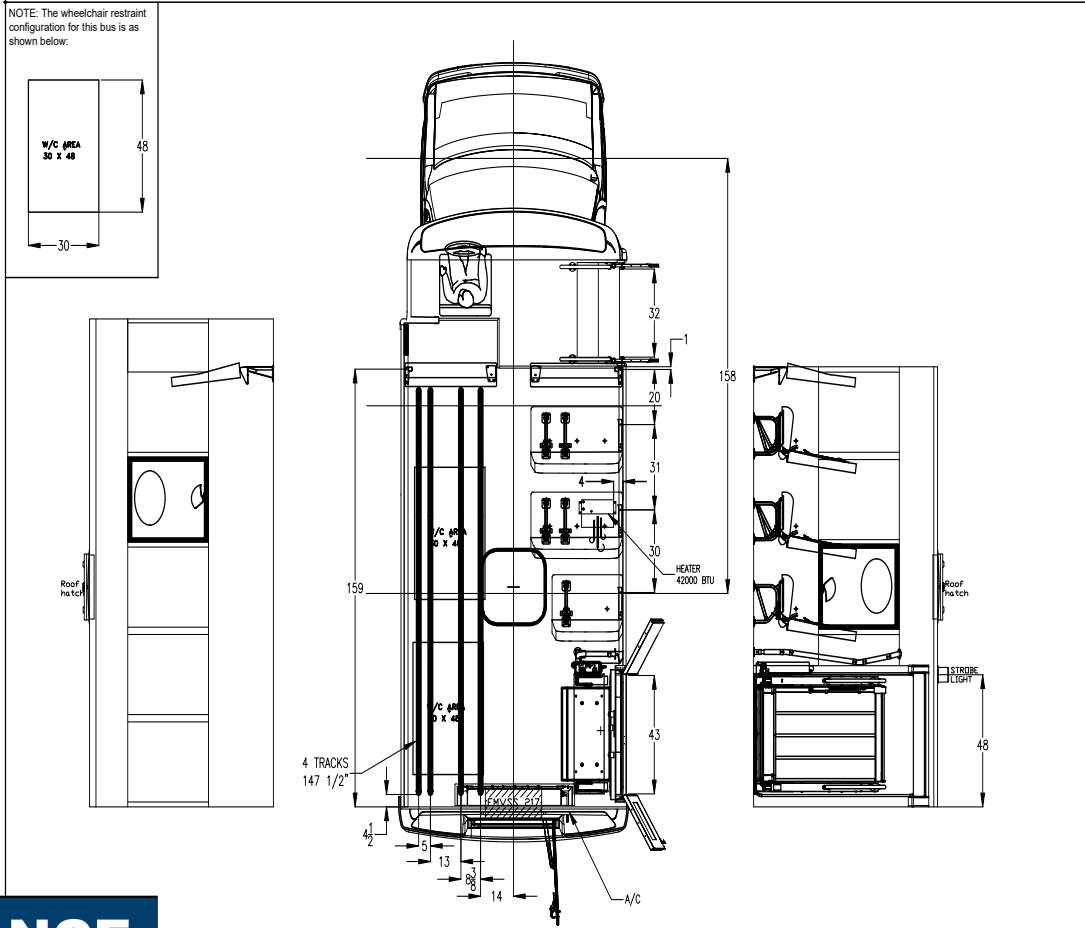

**AT A GLANCE**

**BODY-** MicroBird  
**ENGINE-** Borg-Warner Remy  
**FUEL TYPE-** Electric  
**HP-** Electric  
**TRANS-** Electric  
**CAP-** 8+2  
**WHEELBASE -** 158"  
**ITEM #**BB10

SEAT	DIM.	SIDE	QTY	REV.	DATE	BY	DESCRIPTION	Drawn by :	LINE ROY
S3	39	RH	2	2021/05/27	LR		CREATION DRAWING		MICRO BIRD
S3	30	RH	1						CAPRIUM
Seat spacing = See drawing				D.O.D.: 32"		MODEL: UFH5 CRH WSS			
APPROVED CONFIGURATIONS								UNIT = INCHES	
Total ambulatory passengers : 8				Total wheel chair passengers : 2				Drawing no. 053359	
Load cap. (pass. + cargo) : **kg **lbs				Customer Approval:				Date:	
								NOTE: Any option added to this floorplan shall be approved by the Corporation Micro Bird Inc. technical department.	

Quote Id: 213593      Body Plan / Seat Plan Information

Body Plan: 5014365

**AT A GLANCE**

**ENGINE-** Cummins ISB  
**FUEL TYPE-** Diesel  
**HP-** 220  
**TRANS-** Allison  
**SIZE-** 1910  
**CAP-** 34  
**WHEELBASE -** 169"  
**ITEM #**BB11

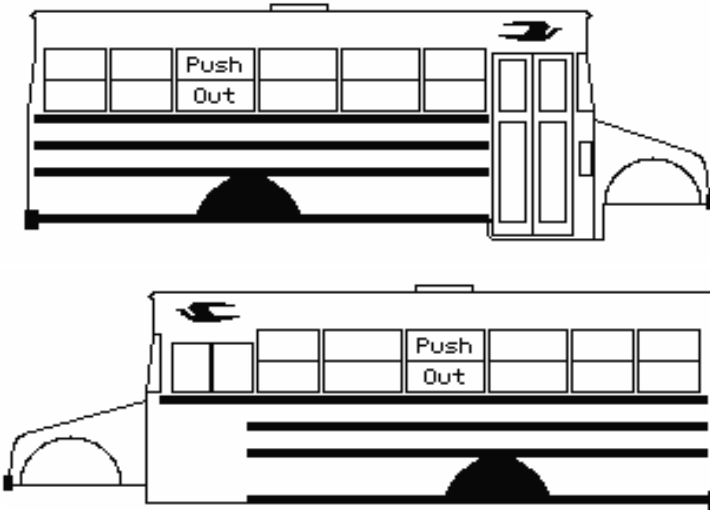

Seat Plan: 23136

SP: 23136 BBCV 1910, 34 CAP



Quote Id: 213593      Seat Plan Spacing Chart

SP: 23136 BBCV 1910, 34 CAP

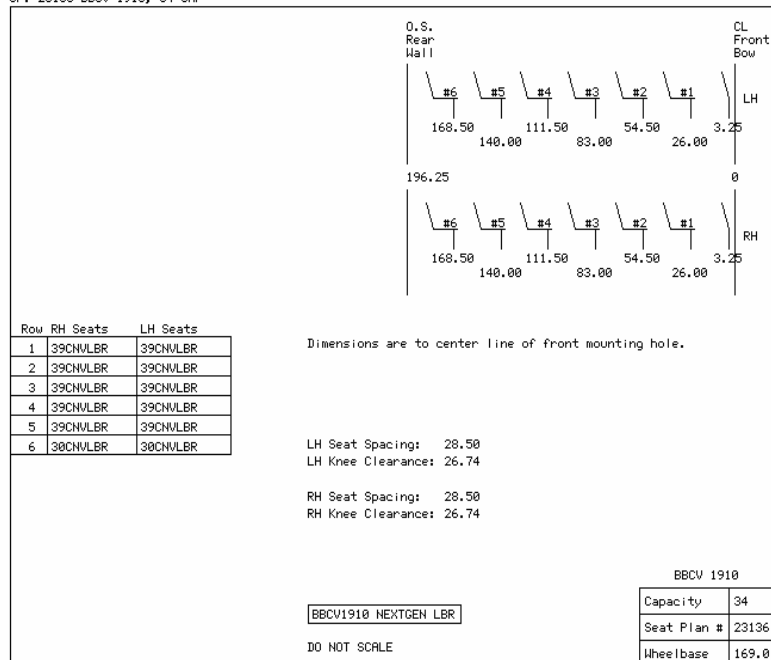

Quote Id: 213594      Body Plan / Seat Plan Information

Body Plan: 5014346

## AT A GLANCE

**ENGINE-** Cummins ISB  
**FUEL TYPE-** Diesel  
**HP-** 220  
**TRANS-** Allison  
**SIZE-** 2311  
**CAP-** 34  
**WHEELBASE -** 189"  
**ITEM #**BB12

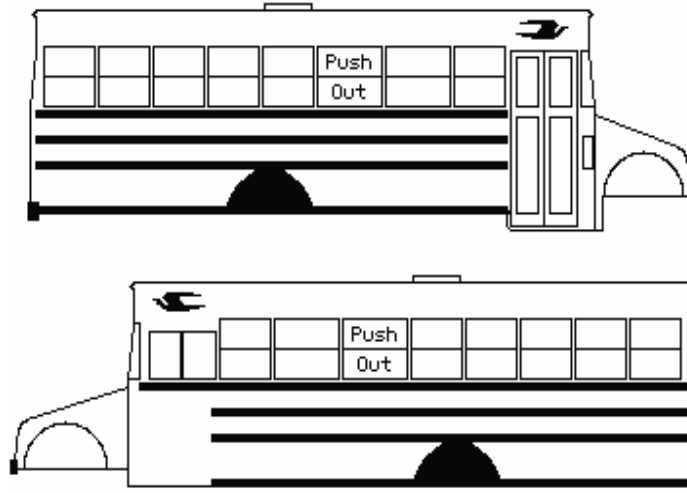

Seat Plan: 23137

SP: 23137 BBCV 2311, 34 CAP



Quote Id: 213594      Seat Plan Spacing Chart

SP: 23137 BBCV 2311, 34 CAP

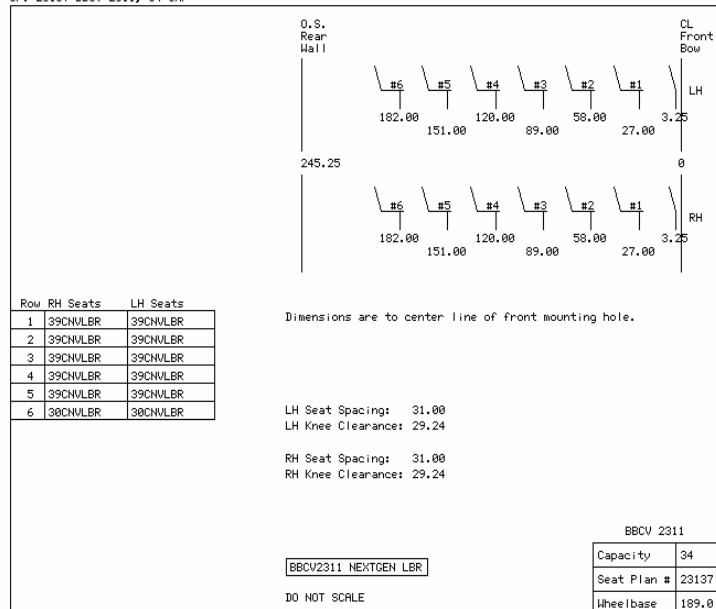

Quote Id: 213595      Body Plan / Seat Plan Information

Body Plan: 5014494

## AT A GLANCE

**ENGINE-** Cummins ISB  
**FUEL TYPE-** Diesel  
**HP-** 220  
**TRANS-** Allison  
**SIZE-** 2610  
**CAP-** 52  
**WHEELBASE -** 217"  
**ITEM #**BB13

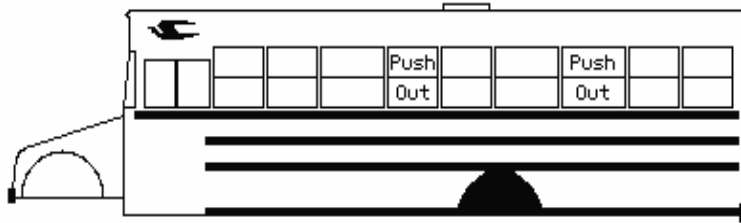
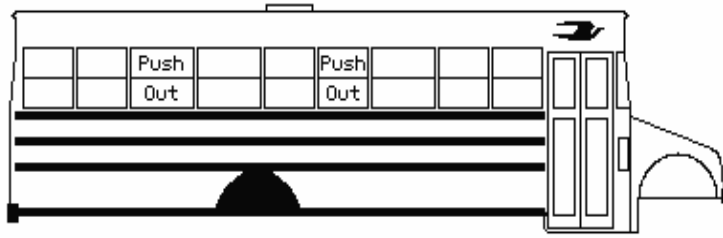

Seat Plan: 23138

SP: 23138 BBCV 2610, 52 CAP



Quote Id: 213595      Seat Plan Spacing Chart

SP: 23138 BBCV 2610, 52 CAP

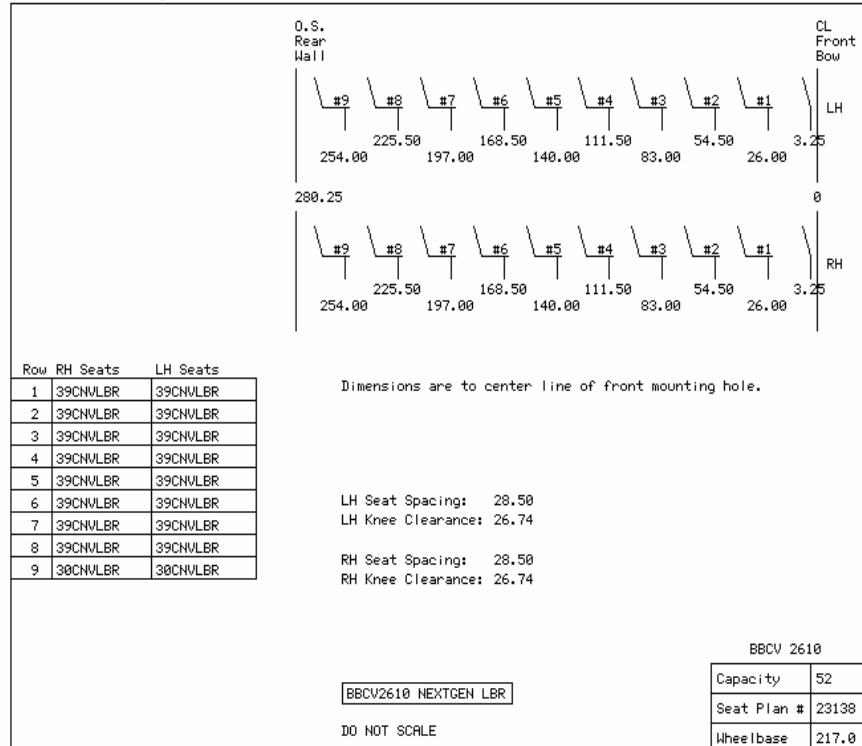



**BLUE BIRD**

Quote Id: 213596      Body Plan / Seat Plan Information

Body Plan: 5014345

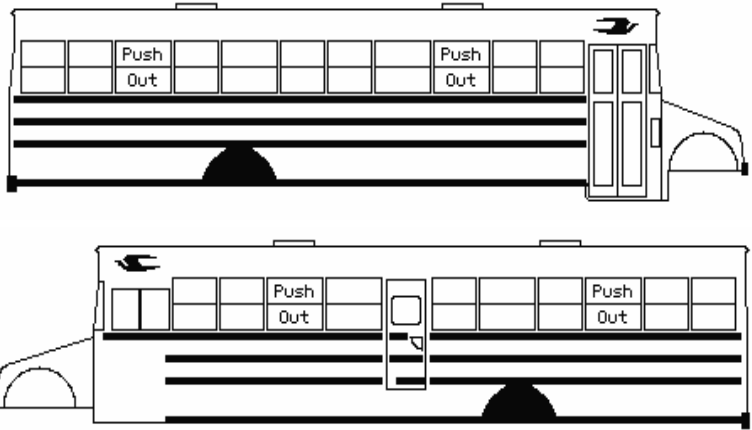

## AT A GLANCE

**ENGINE-** Cummins ISB  
**FUEL TYPE-** Diesel  
**HP-** 220  
**TRANS-** Allison  
**SIZE-** 3201  
**CAP-** 66  
**WHEELBASE -** 273"  
**ITEM #**BB14

Seat Plan: 25141

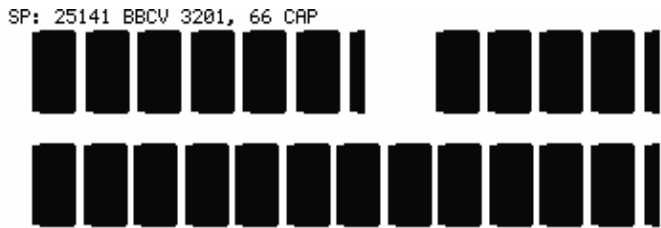

Quote Id: 213596      Seat Plan Spacing Chart

SP: 25141 BBCV 3201, 66 CAP

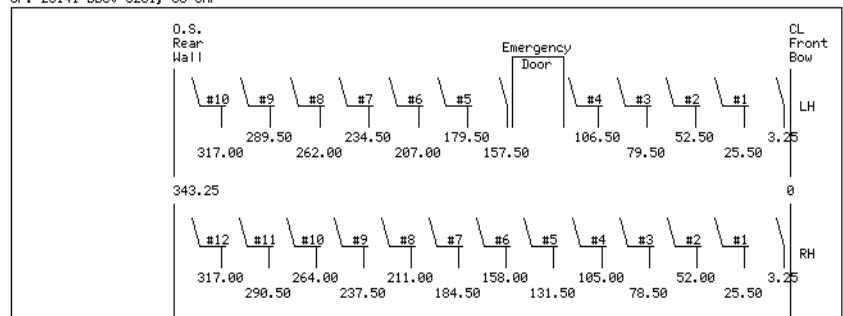

Row	RH Seats	LH Seats
1	39CHVLBR	39CHVLBR
2	39CHVLBR	39CHVLBR
3	39CHVLBR	39CHVLBR
4	39CHVLBR	39CHVLBR
5	39CHVLBR	39CHVLBR
6	39CHVLBR	39CHVLBR
7	39CHVLBR	39CHVLBR
8	39CHVLBR	39CHVLBR
9	39CHVLBR	39CHVLBR
10	39CHVLBR	39CHVLBR
11	39CHVLBR	
12	39CHVLBR	

Dimensions are to center line of front mounting hole.

LH Seat Spacing: 27.00, 27.50  
 LH Knee Clearance: 25.24, 25.74  
 RH Seat Spacing: 26.50  
 RH Knee Clearance: 24.74

BBCV3201 SEDSL NEXTGEN LBR

DO NOT SCALE

BBCV 3201	
Capacity	66
Seat Plan #	25141
Wheelbase	273.0

Quote Id: 213597      Body Plan / Seat Plan Information

Body Plan: 5014345

**AT A GLANCE**

**ENGINE-** Cummins ISB  
**FUEL TYPE-** Diesel  
**HP-** 250  
**TRANS-** Allison  
**SIZE-** 3201  
**CAP-** 66  
**WHEELBASE -** 273"  
**ITEM #**BB15

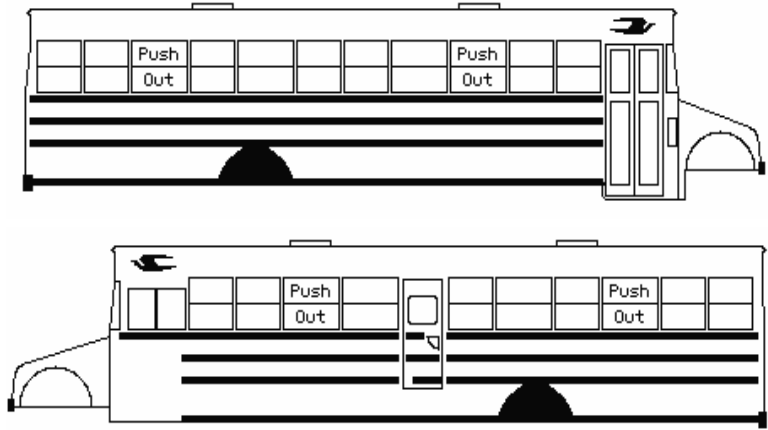

Seat Plan: 25141

SP: 25141 BBCV 3201, 66 CAP



Quote Id: 213597      Seat Plan Spacing Chart

SP: 25141 BBCV 3201, 66 CAP

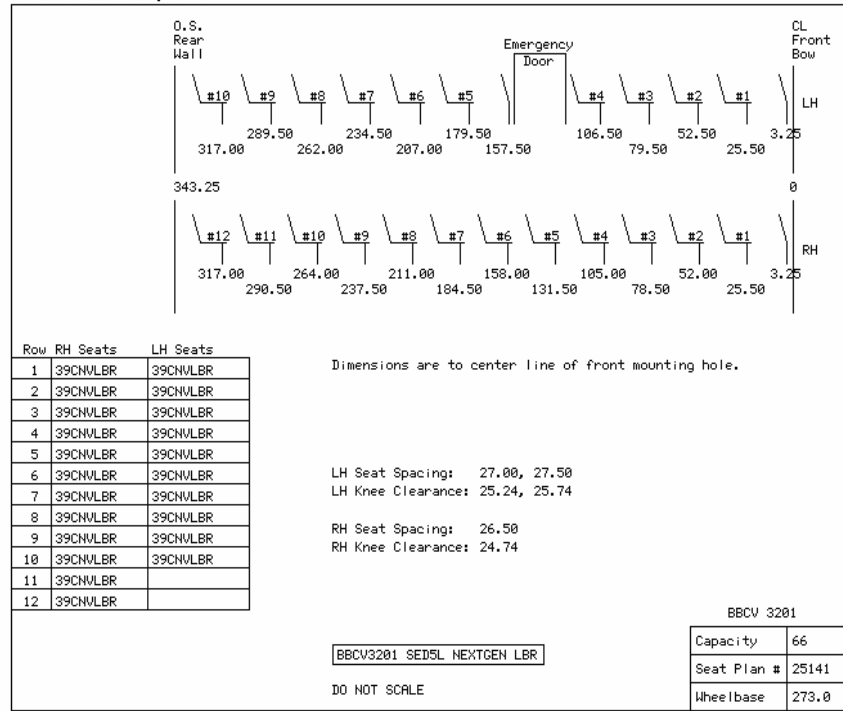



**BLUE BIRD**

Quote Id: 213598      Body Plan / Seat Plan Information

Body Plan: 5014318

**AT A GLANCE**

**ENGINE-** Cummins ISB  
**FUEL TYPE-** Diesel  
**HP-** 220  
**TRANS-** Allison  
**SIZE-** 3310  
**CAP-** 72  
**WHEELBASE -** 273"  
**ITEM #**BB16

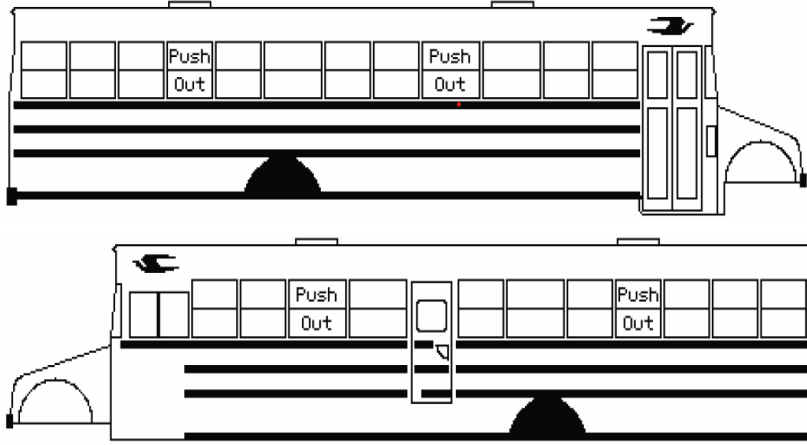

Seat Plan: 30325

SP: 30325 BBCV 3310, 72 CAP

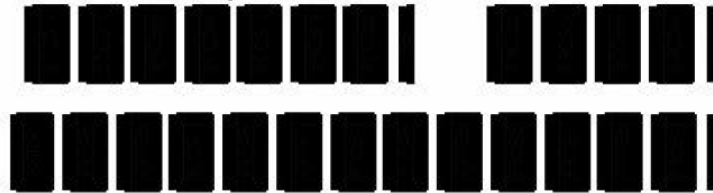

Quote Id: 213598      Seat Plan Spacing Chart

SP: 30325 BBCV 3310, 72 CAP

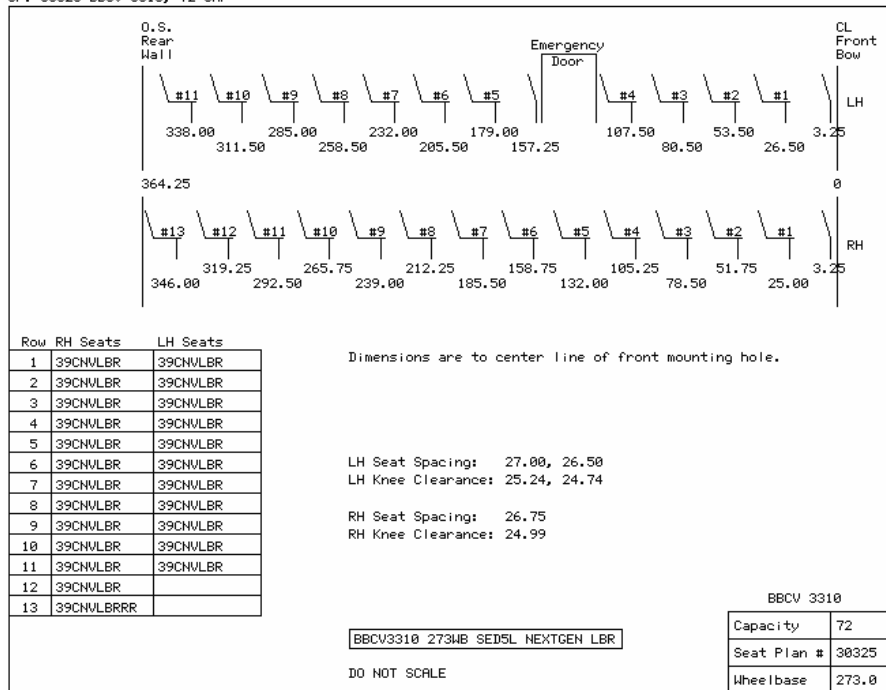



Quote Id: 213599      Body Plan / Seat Plan Information

Body Plan: 5014318

**AT A GLANCE**

**ENGINE-** Cummins ISB  
**FUEL TYPE-** Diesel  
**HP-** 250  
**TRANS-** Allison  
**SIZE-** 3310  
**CAP-** 72  
**WHEELBASE -** 273"  
**ITEM #**BB17

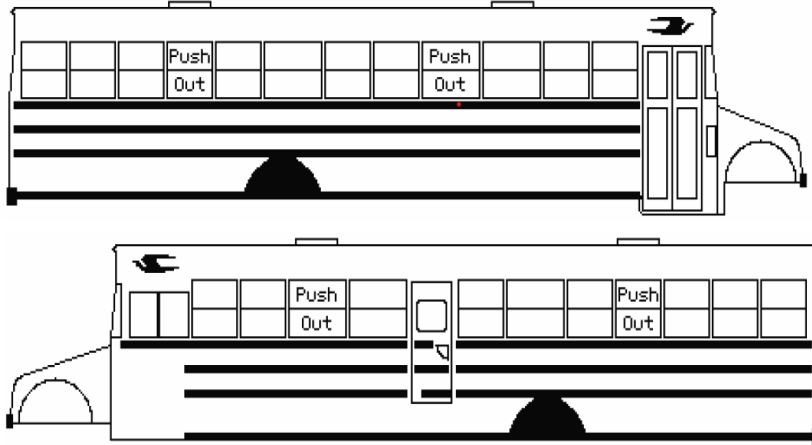

Seat Plan: 30325

SP: 30325 BBCV 3310, 72 CAP

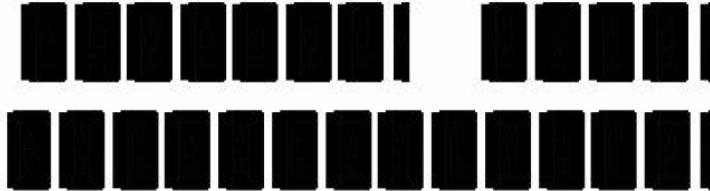

Quote Id: 213599      Seat Plan Spacing Chart

SP: 30325 BBCV 3310, 72 CAP

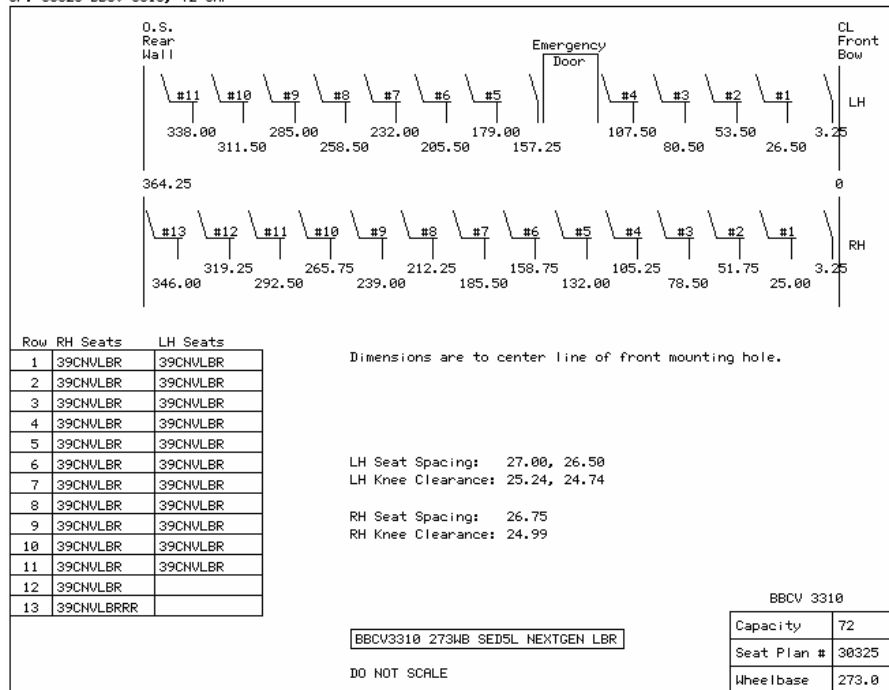

Quote Id: 213600      Body Plan / Seat Plan Information

Body Plan: 5014550

## AT A GLANCE

**ENGINE-** Cummins ISB  
**FUEL TYPE-** Diesel  
**HP-** 250  
**TRANS-** Allison  
**SIZE-** 3507  
**CAP-** 75  
**WHEELBASE -** 280"  
**ITEM #**BB18

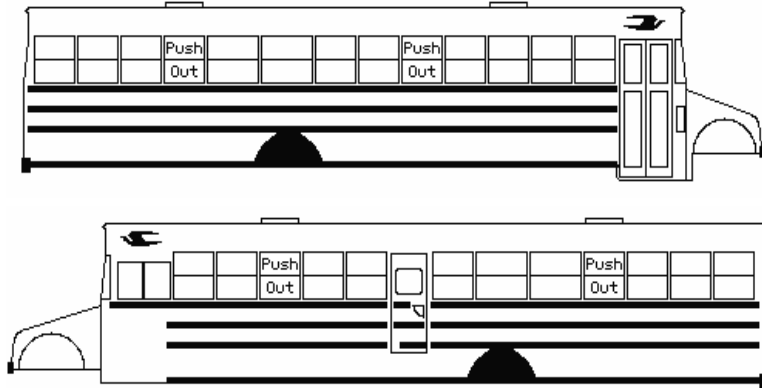

Seat Plan: 27624

SP: 27624 BBCV 3507, 75 CAP



Quote Id: 213600      Seat Plan Spacing Chart

SP: 27624 BBCV 3507, 75 CAP

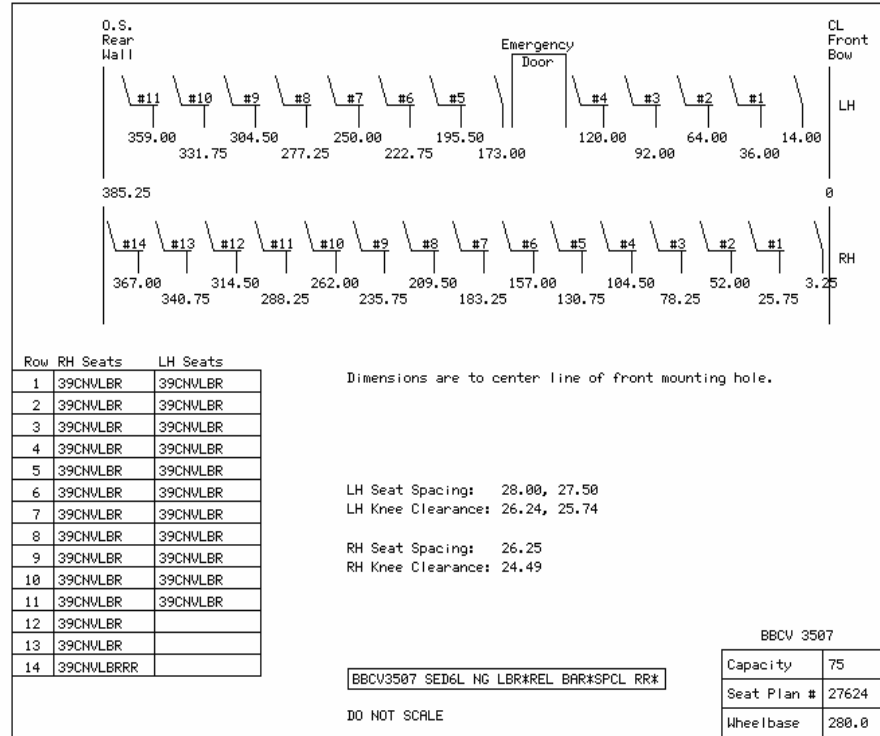

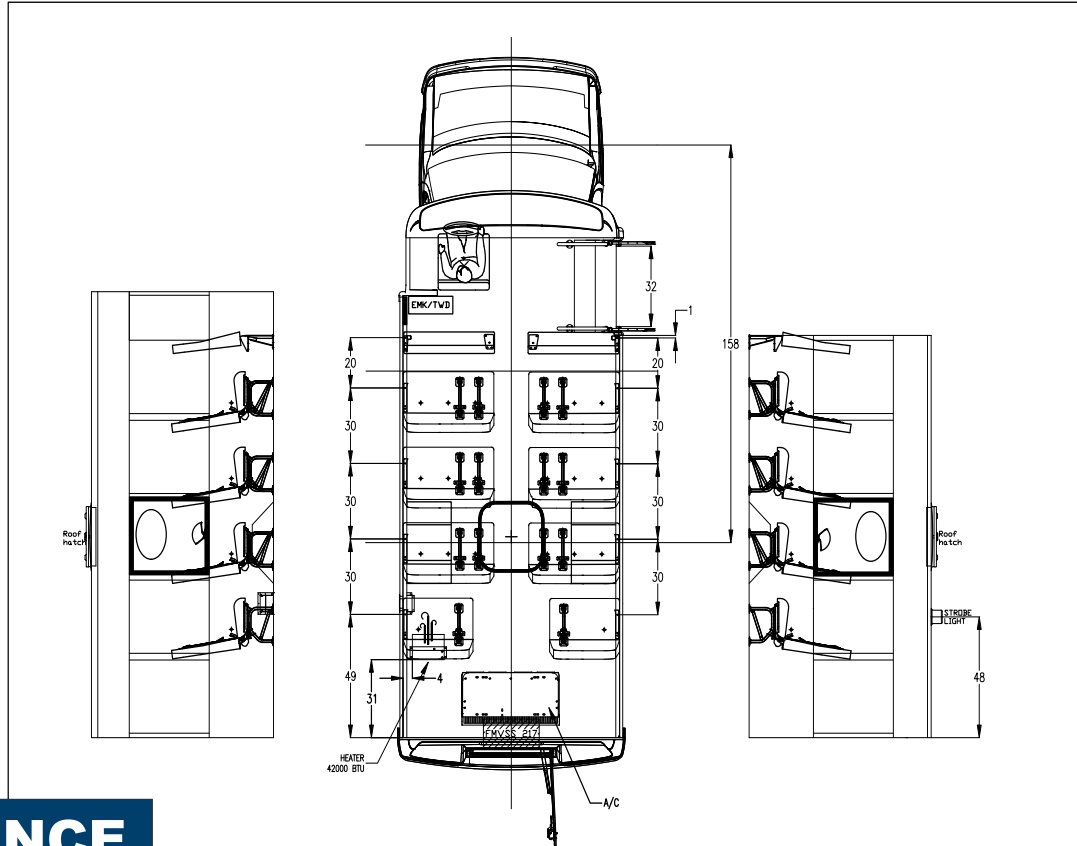

**AT A GLANCE**

**BODY-** Micro Bird  
**ENGINE-** Ford  
**FUEL TYPE-** Propane  
**HP-** 362  
**TRANS-** Ford  
**CAP-** 22  
**WHEELBASE -** 158"  
**ITEM #**BB19

SEAT	DIM.	SIDE	QTY
S3	39	LH	3
S3	30	LH	1
S3	39	RH	3
S3	30	LH	1

Seat spacing = See drawing D.O.D.: 32"

**APPROVED CONFIGURATIONS**

Total ambulatory passengers: 22 Total wheel chair passengers: 0

Load cap. (pass. + cargo): \*\*kg \*\*lbs

REV.	2021/05/27	LR	CREATION DRAWING
REV.	YYYY/MM/DD	BY	DESCRIPTION
Stock Number:			
Customer Approval:			
Date:			

Drawn by:	
LINE ROY	MICRO BIRD *GARDIN
MODEL:	UFHS 2NH WSS
UNIT = INCHES	Drawing no.
SCALE = DO NOT SCALE	053306
NOTE: Any option added to this floorplan shall be approved by the Corporation Micro Bird Inc. technical department.	

Quote Id: 213605      Body Plan / Seat Plan Information

Body Plan: 5014346

**AT A GLANCE**

**ENGINE-** Ford  
**FUEL TYPE-** Propane  
**HP-** 320  
**TRANS-** Ford  
**SIZE-** 2311  
**CAP-** 34  
**WHEELBASE -** 189"  
**ITEM #**BB20

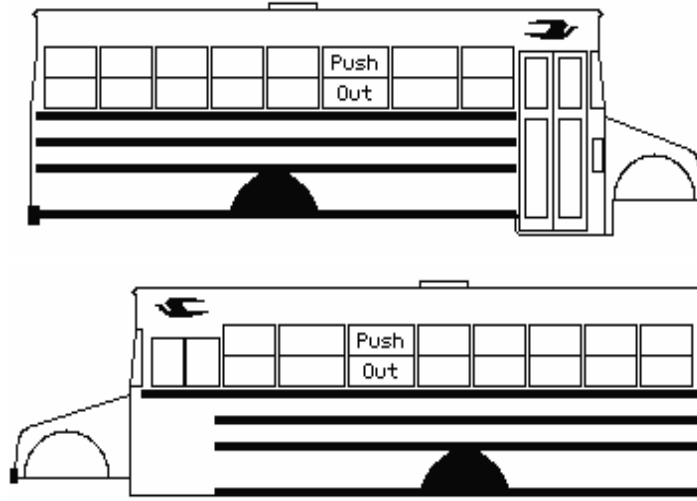

Seat Plan: 23137

SP: 23137 BBCV 2311, 34 CAP



Quote Id: 213605      Seat Plan Spacing Chart

SP: 23137 BBCV 2311, 34 CAP

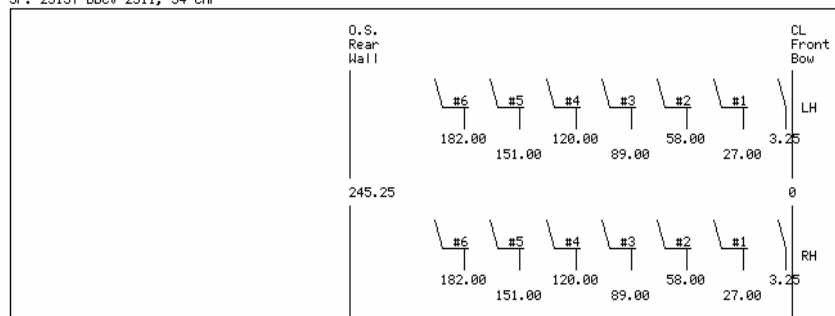

Row	RH Seats	LH Seats
1	39CNVLBR	39CNVLBR
2	39CNVLBR	39CNVLBR
3	39CNVLBR	39CNVLBR
4	39CNVLBR	39CNVLBR
5	39CNVLBR	39CNVLBR
6	30CNVLBR	30CNVLBR

Dimensions are to center line of front mounting hole.

LH Seat Spacing: 31.00  
 LH Knee Clearance: 29.24

RH Seat Spacing: 31.00  
 RH Knee Clearance: 29.24

BBCV 2311

BBCV2311 NEXTGEN LBR

Capacity	34
Seat Plan #	23137
Wheelbase	189.0

DO NOT SCALE

Quote Id: 213607      Body Plan / Seat Plan Information

Body Plan: 5014494

**AT A GLANCE**

**ENGINE-** Ford  
**FUEL TYPE-** Propane  
**HP-** 320  
**TRANS-** Ford  
**SIZE-** 2610  
**CAP-** 52  
**WHEELBASE -** 217"  
**ITEM #**BB21

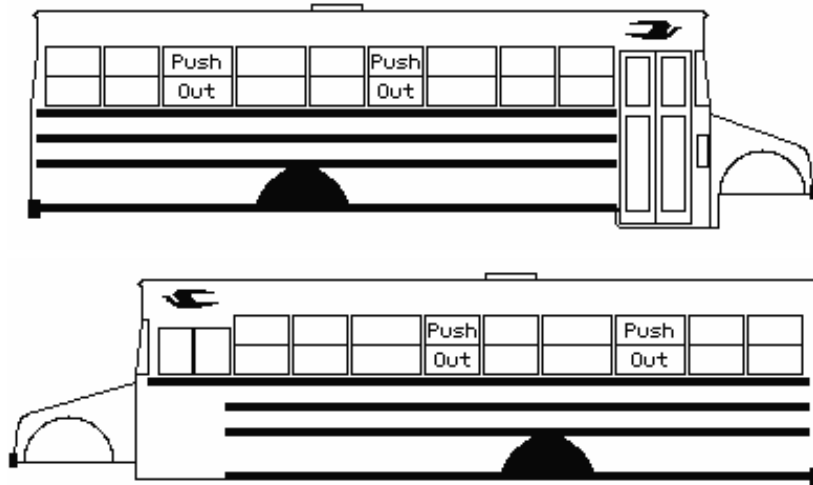

Seat Plan: 23138

SP: 23138 BBCV 2610, 52 CAP



Quote Id: 213607      Seat Plan Spacing Chart

SP: 23138 BBCV 2610, 52 CAP

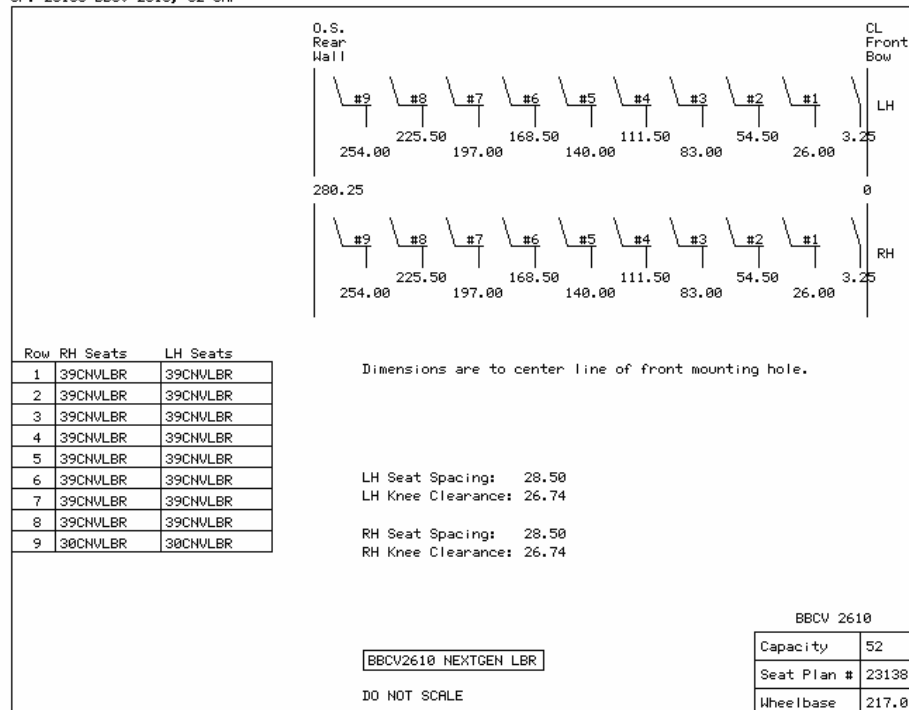

Quote Id: 213608      Body Plan / Seat Plan Information

Body Plan: 5014345

**AT A GLANCE**

**ENGINE-** Ford  
**FUEL TYPE-** Propane  
**HP-** 320  
**TRANS-** Ford  
**SIZE-** 3201  
**CAP-** 66  
**WHEELBASE -** 273"  
**ITEM #**BB22

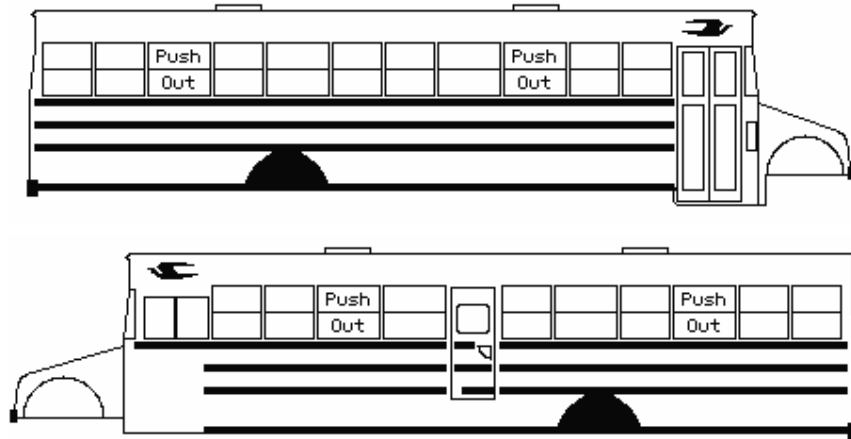

Seat Plan: 25141

SP: 25141 BBCV 3201, 66 CAP



Quote Id: 213608      Seat Plan Spacing Chart

SP: 25141 BBCV 3201, 66 CAP

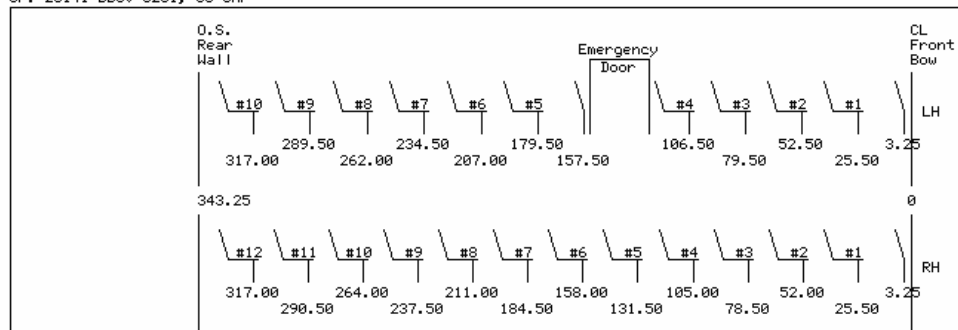

Row	RH Seats	LH Seats
1	39CNVLR	39CNVLR
2	39CNVLR	39CNVLR
3	39CNVLR	39CNVLR
4	39CNVLR	39CNVLR
5	39CNVLR	39CNVLR
6	39CNVLR	39CNVLR
7	39CNVLR	39CNVLR
8	39CNVLR	39CNVLR
9	39CNVLR	39CNVLR
10	39CNVLR	39CNVLR
11	39CNVLR	
12	39CNVLR	

Dimensions are to center line of front mounting hole.

LH Seat Spacing: 27.00, 27.50  
 LH Knee Clearance: 25.24, 25.74  
 RH Seat Spacing: 26.50  
 RH Knee Clearance: 24.74

BBCV3201 SED5L NEXTGEN LBR

DO NOT SCALE

BBCV 3201	
Capacity	66
Seat Plan #	25141
Wheelbase	273.0



**BLUE BIRD**

Quote Id: 213609      Body Plan / Seat Plan Information

Body Plan: 5014318

## AT A GLANCE

**ENGINE-** Ford  
**FUEL TYPE-** Propane  
**HP-** 320  
**TRANS-** Ford  
**SIZE-** 3310  
**CAP-** 72  
**WHEELBASE -** 273"  
**ITEM #BB23**

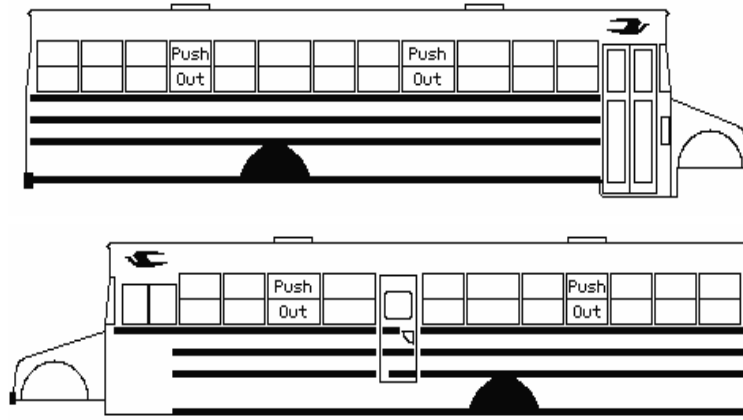

Seat Plan: 30325

SP: 30325 BBCV 3310, 72 CAP



Quote Id: 213609      Seat Plan Spacing Chart

SP: 30325 BBCV 3310, 72 CAP

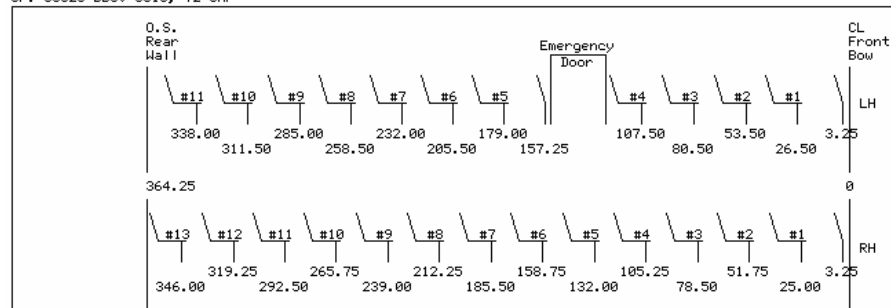

Row	RH Seats	LH Seats
1	39CNVLBR	39CNVLBR
2	39CNVLBR	39CNVLBR
3	39CNVLBR	39CNVLBR
4	39CNVLBR	39CNVLBR
5	39CNVLBR	39CNVLBR
6	39CNVLBR	39CNVLBR
7	39CNVLBR	39CNVLBR
8	39CNVLBR	39CNVLBR
9	39CNVLBR	39CNVLBR
10	39CNVLBR	39CNVLBR
11	39CNVLBR	39CNVLBR
12	39CNVLBR	
13	39CNVLRBR	

Dimensions are to center line of front mounting hole.

LH Seat Spacing: 27.00, 26.50  
 LH Knee Clearance: 25.24, 24.74  
 RH Seat Spacing: 26.75  
 RH Knee Clearance: 24.99

BBCV3310 273WB SED5L NEXTGEN LBR

DO NOT SCALE

BBCV 3310	
Capacity	72
Seat Plan #	30325
Wheelbase	273.0

Quote Id: 213610      Body Plan / Seat Plan Information

Body Plan: 5014318

**AT A GLANCE**

**ENGINE-** Ford  
**FUEL TYPE-** Propane  
**HP-** 320  
**TRANS-** Ford  
**SIZE-** 3310  
**CAP-** 72 EXT  
**WHEELBASE -** 273"  
**ITEM #**BB24

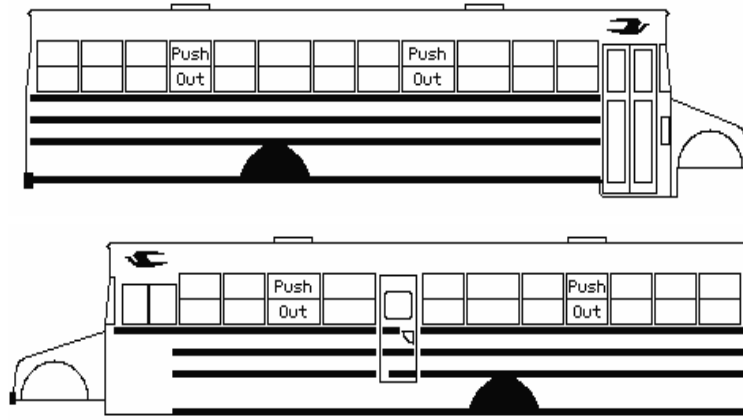

Seat Plan: 30325

SP: 30325 BBCV 3310, 72 CAP



Quote Id: 213610      Seat Plan Spacing Chart

SP: 30325 BBCV 3310, 72 CAP

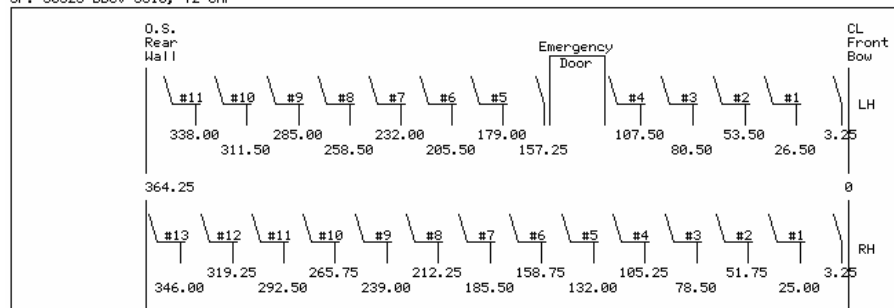

Row	RH Seats	LH Seats
1	39CNVLR	39CNVLR
2	39CNVLR	39CNVLR
3	39CNVLR	39CNVLR
4	39CNVLR	39CNVLR
5	39CNVLR	39CNVLR
6	39CNVLR	39CNVLR
7	39CNVLR	39CNVLR
8	39CNVLR	39CNVLR
9	39CNVLR	39CNVLR
10	39CNVLR	39CNVLR
11	39CNVLR	39CNVLR
12	39CNVLR	
13	39CNVLR	

Dimensions are to center line of front mounting hole.

LH Seat Spacing: 27.00, 26.50  
 LH Knee Clearance: 25.24, 24.74

RH Seat Spacing: 26.75  
 RH Knee Clearance: 24.99

BBCV3310 273WB SED5L NEXTGEN LBR

DO NOT SCALE

BBCV 3310	
Capacity	72
Seat Plan #	30325
Wheelbase	273.0



Quote Id: 213611      Body Plan / Seat Plan Information

Body Plan: 5014550

## AT A GLANCE

**ENGINE-** Ford  
**FUEL TYPE-** Propane  
**HP-** 320  
**TRANS-** Ford  
**SIZE-** 3507  
**CAP-** 75  
**WHEELBASE -** 280"  
**ITEM #**BB25

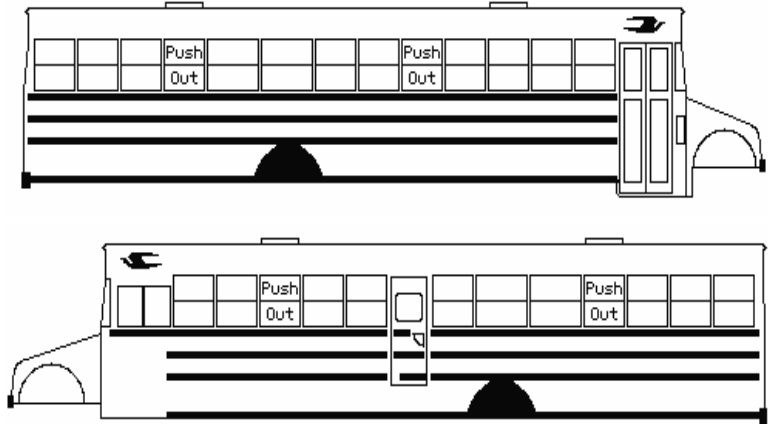

Seat Plan: 27624

SP: 27624 BBCV 3507, 75 CAP



Quote Id: 213611      Seat Plan Spacing Chart

SP: 27624 BBCV 3507, 75 CAP

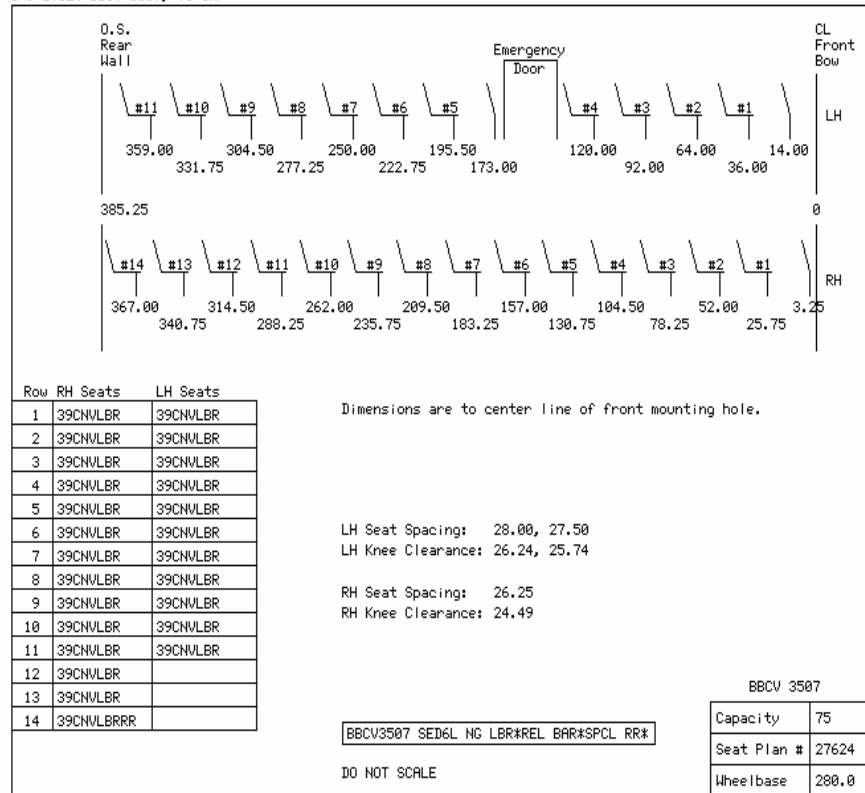

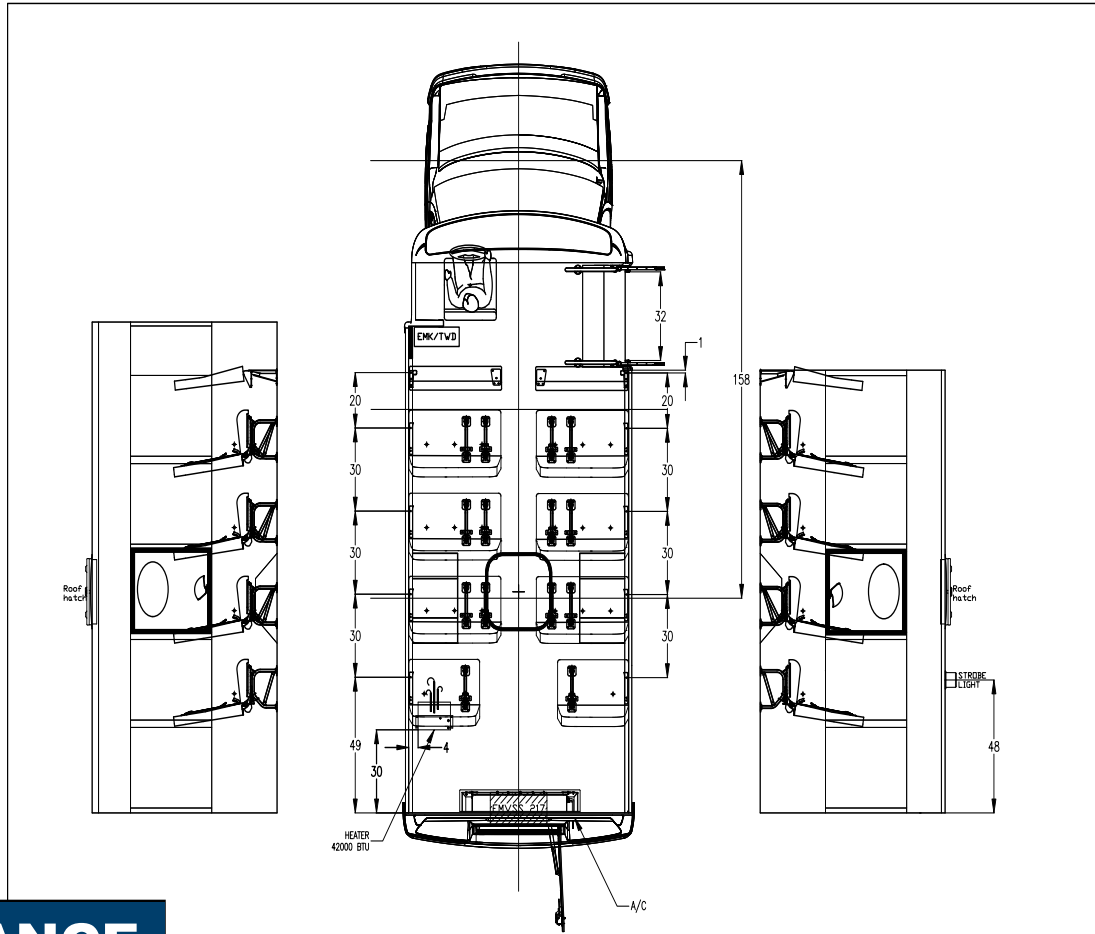

**AT A GLANCE**

**BODY-** MicroBird  
**ENGINE-** Borg-Warner Remy  
**FUEL TYPE-** Electric  
**HP-** Electric  
**TRANS-** Electric  
**CAP-** 22  
**WHEELBASE -** 158"  
**ITEM #**BB26

SEAT	DIM.	SIDE	QTY
S3	39	LH	3
S3	30	LH	1
S3	39	RH	3
S3	30	LH	1

Seat spacing = See drawing D.O.D.: 32"

APPROVED CONFIGURATIONS

Total ambulatory passengers : 22	Total wheel chair passengers : 2
Load cap. (pass. + cargo) : **kg **lbs	

REV.	2021/05/27	LR	DESCRIPTION
	YYYY/MM/DD	BY	
Stock Number:		Customer Approval:	
Date:			

Drawn by : LINE ROY	MICRO BIRD *GARDIN
MODEL: UFH5 2NH WSS	Drawing no. 053358
UNIT = INCHES SCALE = DO NOT SCALE	
NOTE: Any option added to this floorplan shall be approved by the Corporation Micro Bird inc. technical department.	



**BLUE BIRD**

Quote Id: 213617      Body Plan / Seat Plan Information

Body Plan: 5015525

## AT A GLANCE

**ENGINE-** Cummins  
**FUEL TYPE-** Electric  
**HP-** Electric  
**TRANS-** Electric  
**SIZE-** 3310  
**CAP-** 72  
**WHEELBASE -** 273"  
**ITEM #**BB27

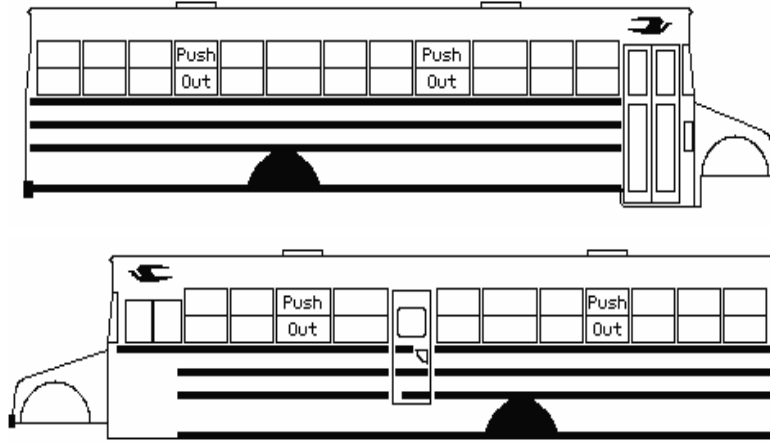

Seat Plan: 30325

SP: 30325 BBCV 3310, 72 CAP



Quote Id: 213617      Seat Plan Spacing Chart

SP: 30325 BBCV 3310, 72 CAP

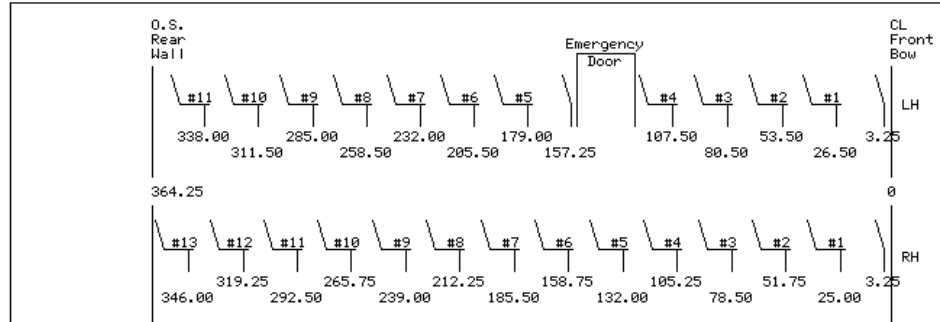

Row	RH Seats	LH Seats
1	39CNVLR	39CNVLR
2	39CNVLR	39CNVLR
3	39CNVLR	39CNVLR
4	39CNVLR	39CNVLR
5	39CNVLR	39CNVLR
6	39CNVLR	39CNVLR
7	39CNVLR	39CNVLR
8	39CNVLR	39CNVLR
9	39CNVLR	39CNVLR
10	39CNVLR	39CNVLR
11	39CNVLR	39CNVLR
12	39CNVLR	
13	39CNVLR	

Dimensions are to center line of front mounting hole.

LH Seat Spacing: 27.00, 26.50  
 LH Knee Clearance: 25.24, 24.74  
 RH Seat Spacing: 26.75  
 RH Knee Clearance: 24.99

BBCV 3310

BBCV3310 273WB SEDSL NEXTGEN LBR

DO NOT SCALE

Capacity	72
Seat Plan #	30325
Wheelbase	273.0

Quote Id: 213615      Body Plan / Seat Plan Information

Body Plan: 5013879

**AT A GLANCE**

**ENGINE-** Cummins ISB  
**FUEL TYPE-** Diesel  
**HP-** 250  
**TRANS-** Allison  
**SIZE-** 3802  
**CAP-** 72  
**WHEELBASE -** 245"  
**ITEM #**BB28

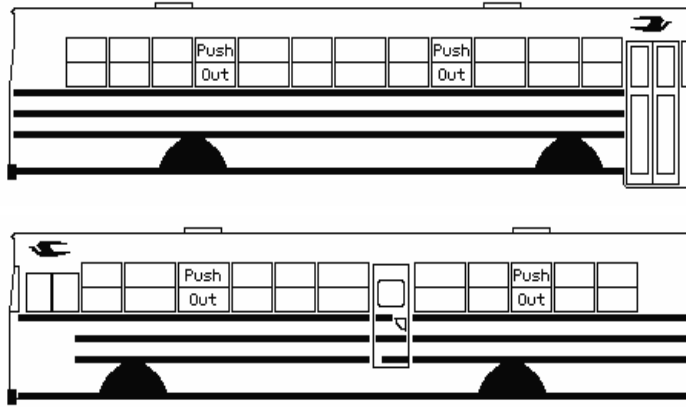

Seat Plan: 29740

SP: 29740 T3RE 3802, 72 CAP



Quote Id: 213615      Seat Plan Spacing Chart

SP: 29740 T3RE 3802, 72 CAP

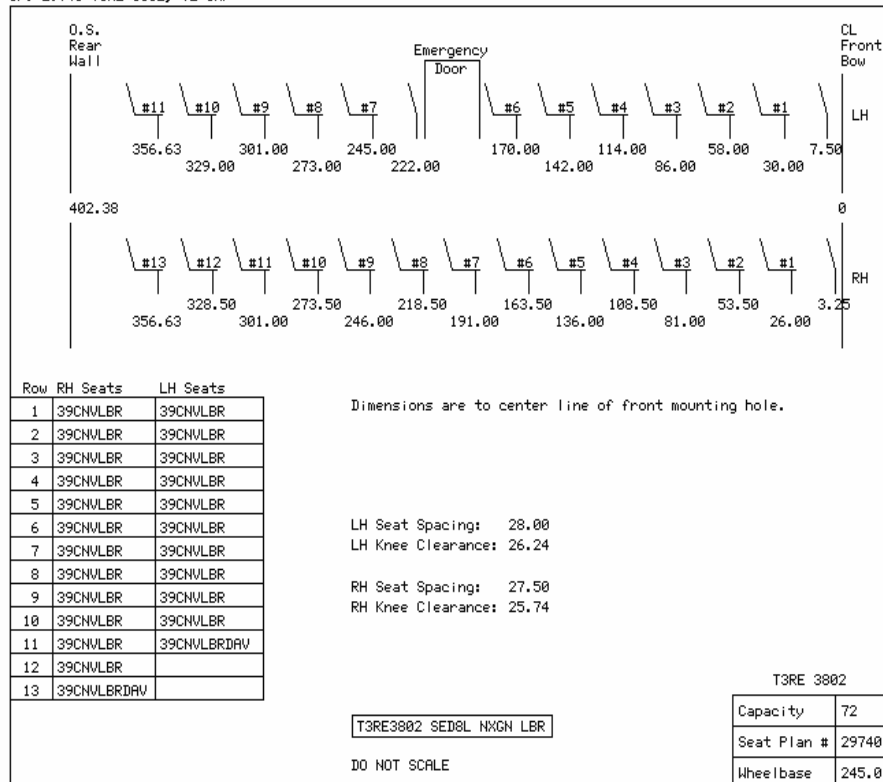



Quote Id: 213616      Body Plan / Seat Plan Information

Body Plan: 5013675

**AT A GLANCE**

**ENGINE-** Cummins ISB  
**FUEL TYPE-** Diesel  
**HP-** 250  
**TRANS-** Allison  
**SIZE-** 4006  
**CAP-** 78  
**WHEELBASE -** 273"  
**ITEM #**BB29

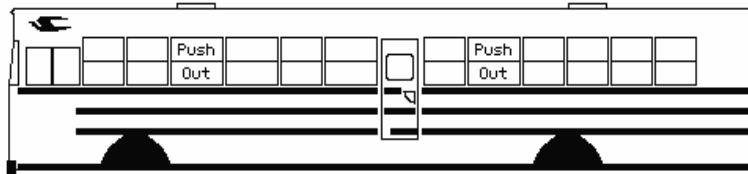
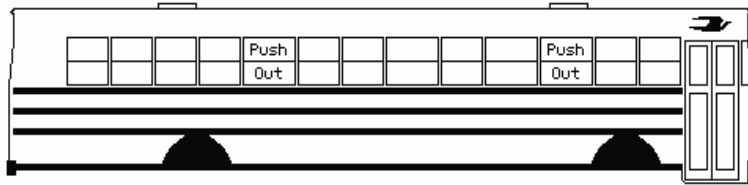

Seat Plan: 25142

SP: 25142 T3RE 4006, 78 CAP



Quote Id: 213616      Seat Plan Spacing Chart

SP: 25142 T3RE 4006, 78 CAP

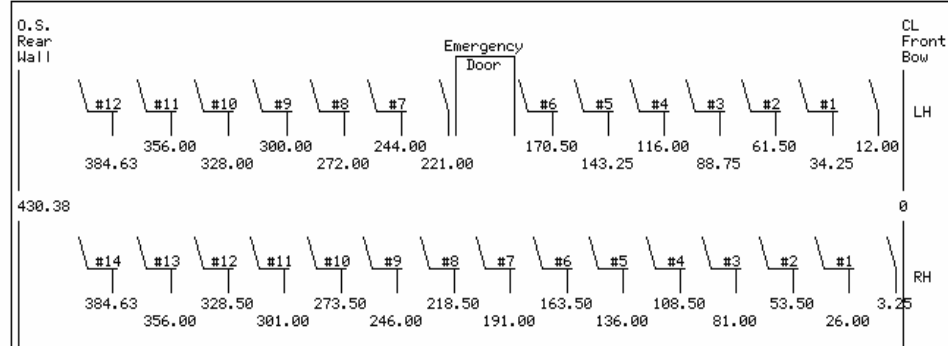

Row	RH Seats	LH Seats
1	39CNVLBR	39CNVLBR
2	39CNVLBR	39CNVLBR
3	39CNVLBR	39CNVLBR
4	39CNVLBR	39CNVLBR
5	39CNVLBR	39CNVLBR
6	39CNVLBR	39CNVLBR
7	39CNVLBR	39CNVLBR
8	39CNVLBR	39CNVLBR
9	39CNVLBR	39CNVLBR
10	39CNVLBR	39CNVLBR
11	39CNVLBR	39CNVLBR
12	39CNVLBR	39CNVLBRDAV
13	39CNVLBR	
14	39CNVLBRDAV	

Dimensions are to center line of front mounting hole.

LH Seat Spacing: 27.25, 28.00  
 LH Knee Clearance: 25.49, 26.24

RH Seat Spacing: 27.50  
 RH Knee Clearance: 25.74

T3RE4006 SED7L NEXTGEN LBR

DO NOT SCALE

T3RE 4006	
Capacity	78
Seat Plan #	25142
Wheelbase	273.0



BLUE BIRD

Quote Id: 213612 Body Plan / Seat Plan Information

Body Plan: 5010770

## AT A GLANCE

**ENGINE-** Cummins ISB  
**FUEL TYPE-** Diesel  
**HP-** 250  
**TRANS-** Allison  
**SIZE-** 3909  
**CAP-** 70  
**WHEELBASE -** 232"  
**ITEM #**BB30

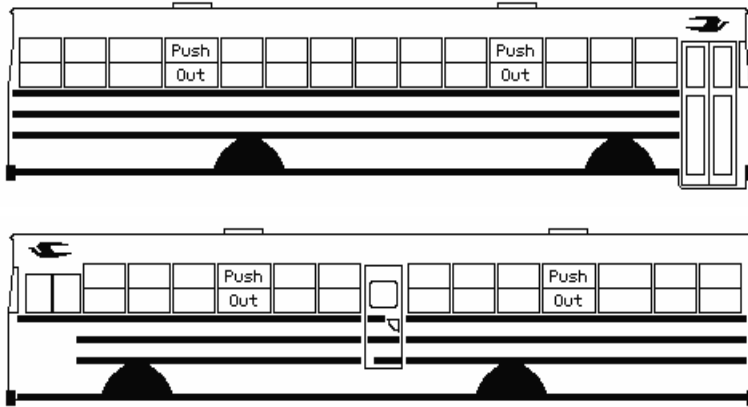

Seat Plan: 23141

SP: 23141 T3FE 3909, 70 CAP



Quote Id: 213612 Seat Plan Spacing Chart

SP: 23141 T3FE 3909, 70 CAP

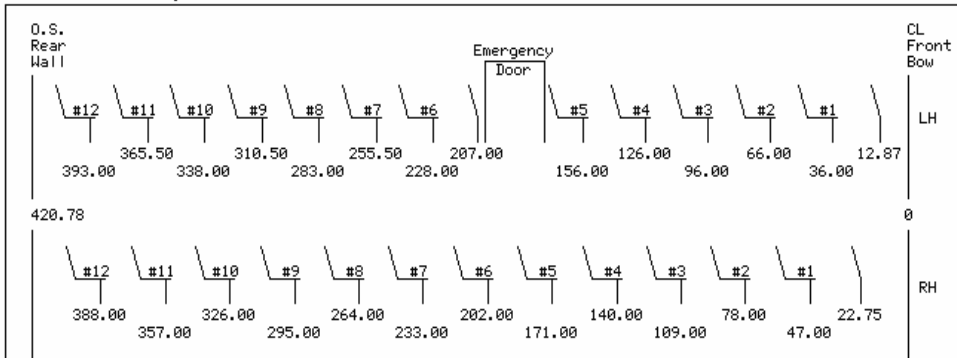

Row	RH Seats	LH Seats
1	39CNVLR	39CNVLR
2	39CNVLR	39CNVLR
3	39CNVLR	39CNVLR
4	39CNVLR	39CNVLR
5	39CNVLR	39CNVLR
6	39CNVLR	39CNVLR
7	39CNVLR	39CNVLR
8	39CNVLR	39CNVLR
9	39CNVLR	39CNVLR
10	39CNVLR	39CNVLR
11	39CNVLR	39CNVLR
12	30CNVLR	30CNVLR

Dimensions are to center line of front mounting hole.

LH Seat Spacing: 30.00, 27.50  
 LH Knee Clearance: 28.24, 25.74  
 RH Seat Spacing: 31.00  
 RH Knee Clearance: 29.24

T3FE 3909

T3FE3909 SED7L NEXTGEN LBR

DO NOT SCALE

Capacity	70
Seat Plan #	23141
Wheelbase	232.0

Quote Id: 213613      Body Plan / Seat Plan Information

Body Plan: 5010767

**AT A GLANCE**

**ENGINE-** Cummins ISB  
**FUEL TYPE-** Diesel  
**HP-** 250  
**TRANS-** Allison  
**SIZE-** 3909  
**CAP-** 74  
**WHEELBASE -** 232"  
**ITEM #**BB31

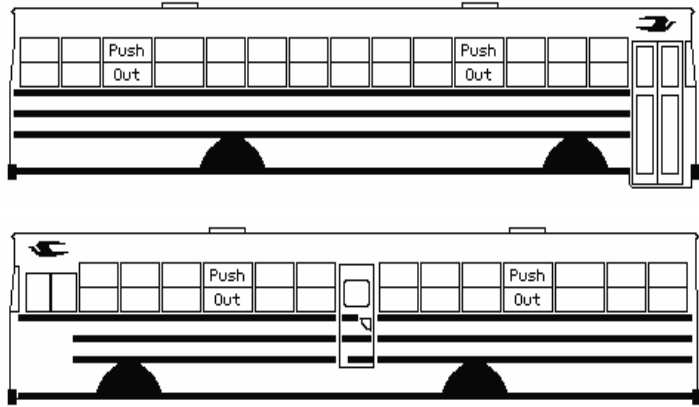

Seat Plan: 23142

SP: 23142 T3FE 3909, 74 CAP



Quote Id: 213613      Seat Plan Spacing Chart

SP: 23142 T3FE 3909, 74 CAP

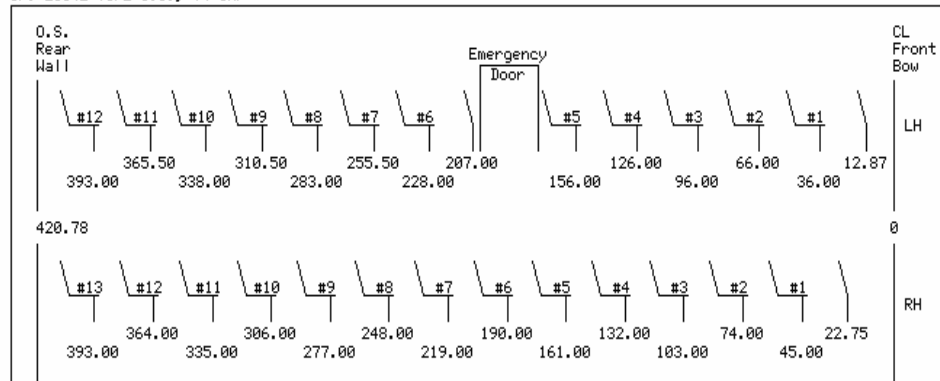

Row	RH Seats	LH Seats
1	39CNVLR	39CNVLR
2	39CNVLR	39CNVLR
3	39CNVLR	39CNVLR
4	39CNVLR	39CNVLR
5	39CNVLR	39CNVLR
6	39CNVLR	39CNVLR
7	39CNVLR	39CNVLR
8	39CNVLR	39CNVLR
9	39CNVLR	39CNVLR
10	39CNVLR	39CNVLR
11	39CNVLR	39CNVLR
12	39CNVLR	39CNVLR
13	30CNVLR	

Dimensions are to center line of front mounting hole.

LH Seat Spacing: 30.00, 27.50  
 LH Knee Clearance: 28.24, 25.74  
 RH Seat Spacing: 29.00  
 RH Knee Clearance: 27.24

T3FE3909 SED7L NEXTGEN LBR

DO NOT SCALE

T3FE 3909	
Capacity	74
Seat Plan #	23142
Wheelbase	232.0



Quote Id: 213614 Body Plan / Seat Plan Information

Body Plan: 5011609

**AT A GLANCE**

**ENGINE-** Cummins ISB  
**FUEL TYPE-** Diesel  
**HP-** 250  
**TRANS-** Allison  
**SIZE-** 4004  
**CAP-** 78  
**WHEELBASE -** 232"  
**ITEM #**BB32

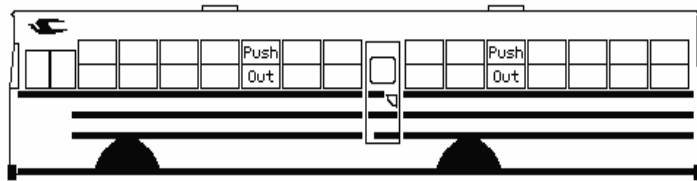
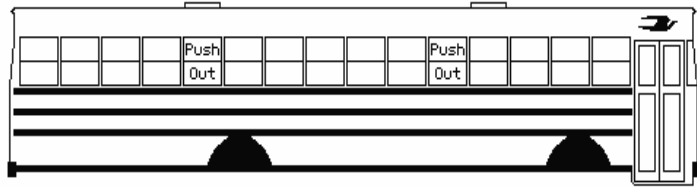

Seat Plan: 23143

SP: 23143 T3FE 4004, 78 CAP



Quote Id: 213614 Seat Plan Spacing Chart

SP: 23143 T3FE 4004, 78 CAP

O.S. Rear Wall | Emergency Door | CL Front Bow

LH | RH

400.00 370.00 340.00 310.00 280.00 250.00 228.00 177.75 148.75 119.75 90.75 61.75 32.75 12.87

427.78

399.75 372.50 345.25 318.00 290.75 263.50 236.25 209.00 181.75 154.50 127.25 100.00 72.75 45.00

Row	RH Seats	LH Seats
1	39CNVLR	39CNVLR
2	39CNVLR	39CNVLR
3	39CNVLR	39CNVLR
4	39CNVLR	39CNVLR
5	39CNVLR	39CNVLR
6	39CNVLR	39CNVLR
7	39CNVLR	39CNVLR
8	39CNVLR	39CNVLR
9	39CNVLR	39CNVLR
10	39CNVLR	39CNVLR
11	39CNVLR	39CNVLR
12	39CNVLR	39CNVLR
13	39CNVLR	
14	39CNVLR	

Dimensions are to center line of front mounting hole.

LH Seat Spacing: 29.00, 30.00  
 LH Knee Clearance: 27.24, 28.24

RH Seat Spacing: 27.25  
 RH Knee Clearance: 25.49

T3FE 4004

Capacity	78
Seat Plan #	23143
Wheelbase	232.0

T3FE4004 SED8L NEXTGEN LBR

DO NOT SCALE





Quote Id: 213618      Body Plan / Seat Plan Information

Body Plan: 5013682

**AT A GLANCE**

**ENGINE-** Cummins  
**FUEL TYPE-** Electric  
**HP-** Electric  
**TRANS-** Electric  
**SIZE-** 4006  
**CAP-** 78  
**WHEELBASE -** 273"  
**ITEM #**BB33

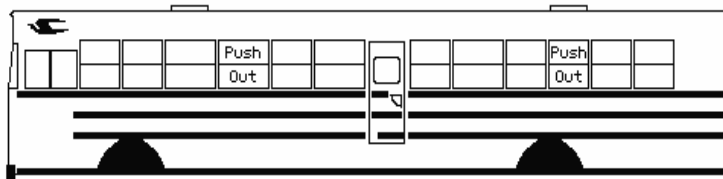

Seat Plan: 25142

SP: 25142 T3RE 4006, 78 CAP



Quote Id: 213618      Seat Plan Spacing Chart

SP: 25142 T3RE 4006, 78 CAP

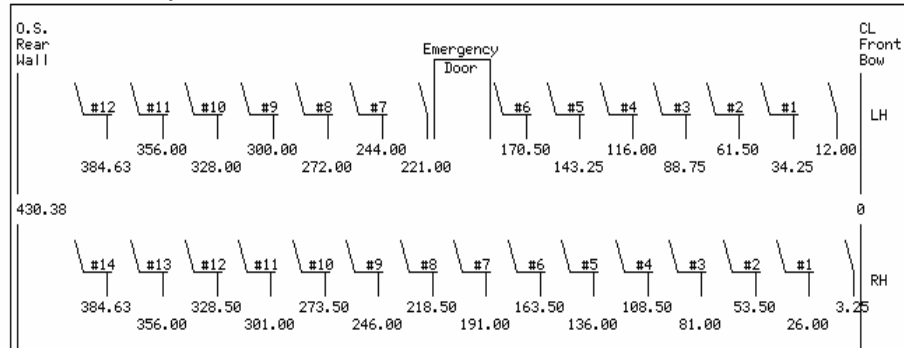

Row	RH Seats	LH Seats
1	39CNVLBR	39CNVLBR
2	39CNVLBR	39CNVLBR
3	39CNVLBR	39CNVLBR
4	39CNVLBR	39CNVLBR
5	39CNVLBR	39CNVLBR
6	39CNVLBR	39CNVLBR
7	39CNVLBR	39CNVLBR
8	39CNVLBR	39CNVLBR
9	39CNVLBR	39CNVLBR
10	39CNVLBR	39CNVLBR
11	39CNVLBR	39CNVLBR
12	39CNVLBR	39CNVLBRDAV
13	39CNVLBR	
14	39CNVLBRDAV	

Dimensions are to center line of front mounting hole.

LH Seat Spacing: 27.25, 28.00  
 LH Knee Clearance: 25.49, 26.24

RH Seat Spacing: 27.50  
 RH Knee Clearance: 25.74

T3RE4006 SED7L NEXTGEN LBR

DO NOT SCALE

T3RE 4006	
Capacity	78
Seat Plan #	25142
Wheelbase	273.0



**KENTUCKY DEPARTMENT OF EDUCATION  
2023 INTERNATIONAL SCHOOL BUS PURCHASE AUTHORIZATION**

The Board of Education \_\_\_\_\_, Kentucky, on \_\_\_\_\_, 20\_\_\_\_, in a legally called and constituted meeting, did vote to purchase school buses through the Kentucky State Contract price procedure.

This Board of Education took this official action in order to authorize the Chief State School Officer to procure 2023 school buses. This action, as spread upon the minutes of the meeting of this Board of Education on the above date, should be construed as evidence of obligation of this Board of Education to purchase the above school buses through State Price Contract agreements established in accordance with statutory authority.

Signed

\_\_\_\_\_, Secretary  
\_\_\_\_\_, Superintendent  
Of \_\_\_\_\_, Board of Education  
Date \_\_\_\_\_.

**BODY SIDE NUMBERS:** Indicate the body side number the Board of Education wants painted on the body side of each school bus. Match body side number to individual item numbers. Example: Item 1 - Side number - 5, 6, 7, 8

---



---



---



---

**DUE TO SUPPLY CHAIN ISSUES, CURRENT LEAD TIMES FOR BUS COMPLETION IS 240-270 DAYS**

ATTACH ADDITIONAL INFORMATION IF NECESSARY



**2023 International Corp Purchase Authorization**  
**BOARD OF EDUCATION**



**Special Needs Diesel**

**All International buses have air brakes. All Type C buses have rear fuel tank locations.**

Item #	Quantity	Bus Type	Capacity	Engine	Chassis	HP	Transmission	Wheel Base	Rear Axle Overhang	Base Price
IC-01		C	34	Cummins B6.7	International	220	Allison 2500PTS	170	93	\$110,395
IC-02		C	52	Cummins B6.7	International	220	Allison 2500PTS	218	127	\$111,495
IC-03		C	52	Cummins B6.7	International	250	Allison 2500PTS	218	127	\$112,095
IC-04		C	66	Cummins B6.7	International	220	Allison 2500PTS	276	140	\$115,895
IC-05		C	66	Cummins B6.7	International	250	Allison 2500PTS	276	140	\$116,495
IC-06		C	66	Cummins B6.7	International	220	Allison 3000PTS	276	140	\$119,795
IC-07		C	66	Cummins B6.7	International	250	Allison 3000PTS	276	140	\$120,395

**Special Needs Propane**

Item #	Quantity	Bus Type	Capacity	Engine	Chassis	HP	Transmission	Wheel Base	Rear Axle Overhang	Base Price
IC-08		C	52	PSI 8.8L	International	270	Allison 2500PTS	218	127	\$122,995
IC-09		C	66	PSI 8.8L	International	270	Allison 2500PTS	276	140	\$127,795

**Type A/C – Diesel**

Type A diesel has a left side middle fuel tank. All others have center rear fuel tank.

Item #	Quantity	Bus Type	Capacity	Engine	Chassis	HP	Transmission	Wheel Base	Rear Axle Overhang	Base Price
IC-10		C	34	Cummins B6.7	International	220	Allison 2500PTS	170	93	\$101,995
IC-11		C	52	Cummins B6.7	International	220	Allison 2500PTS	218	127	\$104,995
IC-12		C	52	Cummins B6.7	International	250	Allison 2500PTS	218	127	\$105,595
IC-13		C	66	Cummins B6.7	International	220	Allison 2500PTS	276	140	\$108,995
IC-14		C	66	Cummins B6.7	International	250	Allison 2500PTS	276	140	\$109,595
IC-15		C	72	Cummins B6.7	International	220	Allison 2500PTS	276	158	\$107,995
IC-16		C	72	Cummins B6.7	International	250	Allison 2500PTS	276	158	\$108,595
IC-17		C	66	Cummins B6.7	International	220	Allison 3000PTS	276	140	\$111,195
IC-18		C	66	Cummins B6.7	International	250	Allison 3000PTS	276	140	\$111,795
IC-19		C	72	Cummins B6.7	International	220	Allison 3000PTS	276	158	\$111,695
IC-20		C	72	Cummins B6.7	International	250	Allison 3000PTS	276	158	\$112,295



**2023 International Corp Purchase Authorization**  
**BOARD OF EDUCATION**



**Type A/C Propane**

**All Type C buses have rear fuel tank locations.**

Item #	Quantity	Bus Type	Capacity	Engine	Chassis	HP	Transmission	Wheel Base	Rear Axle Overhang	Base Price
IC-21		C	52	PSI 8.8L	International	270	Allison 2500PTS	218	127	\$116,395
IC-22		C	66	PSI 8.8L	International	270	Allison 2500PTS	276	149	\$120,095
IC-23		C	72	PSI 8.8L	International	270	Allison 2500PTS	276	158	\$119,995

**Type A/C Electric**

Item #	Quantity	Bus Type	Capacity	Engine	Chassis	HP	Transmission	Wheel Base	Rear Axle Overhang	Base Price
IC-24		C	52	255 KW	International	342	210 KWh	218	127	\$367,495
IC-25		C	72	255 KW	International	342	210 KWh	276	158	\$369,495

**RADIO**

Option #	Bus Type	Option Type	Extended Description	Price
ICO-01	C-34/52	Radio	AM/FM/P.A. with four interior speakers and outside	\$513
ICO-02	C -66/72	Radio	AM/FM/P.A. with six interior speakers and outside speaker	\$551

**CAMERA**

Option #	Bus Type	Option Type	Extended Description	Price
ICO-03	C	Video System	Seon DH4H500G 4 channel video system with 1 camera head and 500 GB hard drive	\$2075
ICO-04	C	Video System	Seon DH6H500G 6 channel video system with 1 camera head and 500 GB hard drive	\$2,321
ICO-05	C	Video System	Seon Stop Arm Camera (installed with system above)	\$590
ICO-06	C	Video System	Seon Additional camera head (installed with system above)	\$445
ICO-07	C	Video System	Seon Pedestal for Forward facing (windshield) camera	\$80
ICO-08	C	Video System	Seon Sensor Harness, Event Marker, GPS Antenna	\$322
ICO-09	C	Video System	Seon DH8H1T0 - M 8 channel video system with 1 camera head and 1 TB hard drive	\$2884
ICO-10	C	Video System	Seon Wi-Fi Antenna for video download	\$244
ICO-11	C	Video System	REI HD6 6 channel video system with 1 camera head and 500 GB hard drive	\$2152
ICO-12	C	Video System	REI Additional camera head (installed with system above)	\$295
ICO-13	C	Video System	REI Event Marker installed with a new video system	\$130
ICO-14	C	Video System	REI Sensor Harness installed with a new video system	\$190
ICO-15	C	Video System	REI - Add Stop Arm camera to a new HD6 video system with 4 camera heads	\$713
ICO-16	C	Video System	REI - Add Stop Arm camera to a new HD6 video system with 1, 2, or 3 camera heads	\$452
ICO-17	C	Video System	REI HD5 12 channel video system with 1 camera head and 500 GB hard drive	\$2977
ICO-18	C	Video System	REI Pedestal mount for forward-facing (windshield) camera	\$80

**LUGGAGE**

Option #	Bus Type	Option Type	Extended Description	Price
ICO-19	C - 52	Luggage	Left Center 91" x 24" x 18" (47EVB)	\$1050
ICO-20	C - 52	Luggage	Right Center 66" x 24" x 18" (47ESX)	\$870
ICO-21	C - 66	Luggage	Left Center 114" x 24" x 18" (47EVV)	\$1182
ICO-22	C - 66	Luggage	Right Center 114" x 24" x 18" (47EVT)	\$1182
ICO-23	C - 66	Luggage	Right Rear 36" x 20" x 18" (47GAG)	\$662
ICO-24	C - 72	Luggage	Left Center 114" x 24" x 18" (47EVV)	\$1,182
ICO-25	C - 72	Luggage	Right Center 114" x 24" x 18" (47EVT)	\$1182
ICO-26	C - 72	Luggage	Right Rear " x 20" x 18" (47GAG)	\$700

**AIR CONDITIONING**

Option #	Bus Type	Option Type	Extended Description	Price
ICO-27	C - Diesel	A/C	85,000 BTU for 34 pass size	\$9,644
ICO-28	C - Diesel or Propane	A/C	110,000 BTU for 52 thru 72 pass size	\$10,583
ICO-29	C - Diesel	A/C	120,000 BTU for 52 thru 72 pass size	\$10,791
ICO-30	C - Electric	A/C	120,000 BTU for 52 thru 72 pass size	\$24,425

**TIRES**

Option #	Bus Type	Option Type	Extended Description	Price
ICO-31	C	Tires	16 ply Continental instead of 14 ply Continental	\$211
ICO-32	C	Tires	14 ply Goodyear instead of 14 ply Continental	\$432
ICO-33	C	Tires	14 ply Michelin instead of 14 ply Continental	\$348

**FUEL TANK**

Option #	Bus Type	Option Type	Extended Description	Price
ICO-34	C Diesel - (66 or 72)	Fuel Tank	100 gallon diesel fuel tank instead of 65 gallon	\$663

**WARRANTY**

Option #	Bus Type	Option Type	Extended Description	Price
ICO-35	C	Warranty	Extended Tow Warranty - 3 yrs/unlimited miles (\$550 max per incident)	\$2,000
ICO-36	C	Warranty	Extended Tow Warranty - 3 yrs/unlimited miles (\$1100 max per incident)	\$2,250

**SEATING**

Option #	Bus Type	Option Type	Extended Description	Price
ICO-37	C	Seats	U.C.R.A. added to seat (per seat)	\$69
ICO-38	C	Seats	39" IMMI Child Restraint Seat instead of 39" regular seat (per seat)	\$828
ICO-39	C	Seats	39" seat with 3-point seatbelts (per seat)	\$597
ICO-40	C	S/N	30" IMMI Child Restraint Seat with 3 point instead of 30" with 3 point (per seat)	\$1253
ICO-41	C	S/N	30" Track-mounted seat with 3 point belts (per seat)	\$1184
ICO-42	C	S/N	30" Track-mounted Barrier	\$417
ICO-43	C	S/N	Delete one Wheelchair Position	\$356
ICO-44	C	S/N	Add One Wheelchair Position	\$671

**OTHER OPTIONS**

Option #	Bus Type	Option Type	Extended Description	Price
ICO-45	C	Adjustable Pedals	Adjustable Pedals (includes tilt/tele steering column)	\$919
ICO-46	C	Brakes	Air Disc Brakes instead of Air Drum Brakes	\$1733
ICO-47	C	Collision Mitigation	Bendix Wingman Advanced (base level CM)	\$1039
ICO-48	C	Collision Mitigation	Bendix Wingman Fusion (includes camera and front sensor)	\$3,006
ICO-49	C	Engine Brake	Engine Brake for Cummins B6.7	\$148
ICO-50	C - 34	Floor	5/8" Marine Grade plywood subfloor with sealed edges	\$973
ICO-51	C - 52	Floor	5/8" Marine Grade plywood subfloor with sealed edges	\$1089
ICO-52	C - 66/72	Floor	5/8" Marine Grade plywood subfloor with sealed edges (47SUB)	\$1220
ICO-53	C	Floor	One-piece floor covering material (48UWV)	\$701
ICO-54	C	Interior	Barrier Cover with Pouch (48BDG)	\$90
ICO-55	C	Interior	Trash Can in Driver Area	\$142
ICO-56	C	Interior	Driver's Dome Light with separate switch	\$52
ICO-57	C	Interior	Power Outlet - 12 volt for GPS	\$54
ICO-58	C	Mirrors	Rosco Eurostyle Mirrors instead of Open View ES	\$246
ICO-59	C	Mirrors	Heated Crossover Mirrors	\$55
ICO-60	C	Special	Sure-Lok GO-2 Oxygen Cylinder Holder	\$405
ICO-61	C	Steering Column	Tilt/Telescopic Steering Column (005710)	\$450
ICO-62	C	Tow Hooks	Front Tow Hooks, Two (001570)	\$119
ICO-63	C	Tow Hooks	Rear Tow Hooks, Two (01WRP)	\$106
ICO-64	C - 34	Windows	Tinted Windows (non-special needs) (48BTV)	\$515
ICO-65	C - 52	Windows	Tinted Windows (non-special needs) (48BTX)	\$629
ICO-66	C - 66/72	Windows	Tinted Windows (non-special needs) (48BUB)	\$730

LEFT SIDE ABOVE FLOOR OR LOW PROFILE ABOVE FLOOR OR BELOW FLOOR FUEL FILL OPTIONS NOT AVAILABLE

RIGHT SIDE ABOVE FLOOR FUEL FILL OPTIONS NOT AVAILABLE

35 GAL RSM TANK OPTION WILL REDUCE SERVICEABILITY OF SENDING UNIT.

**BODY PLAN**

WHEELBASE 170"

PB10500, 19 FT. 11 IN., CAP 14, SEAT SIZE 30/30, SEAT SPACING VARIES, LIFT-FRONT, 2-WC

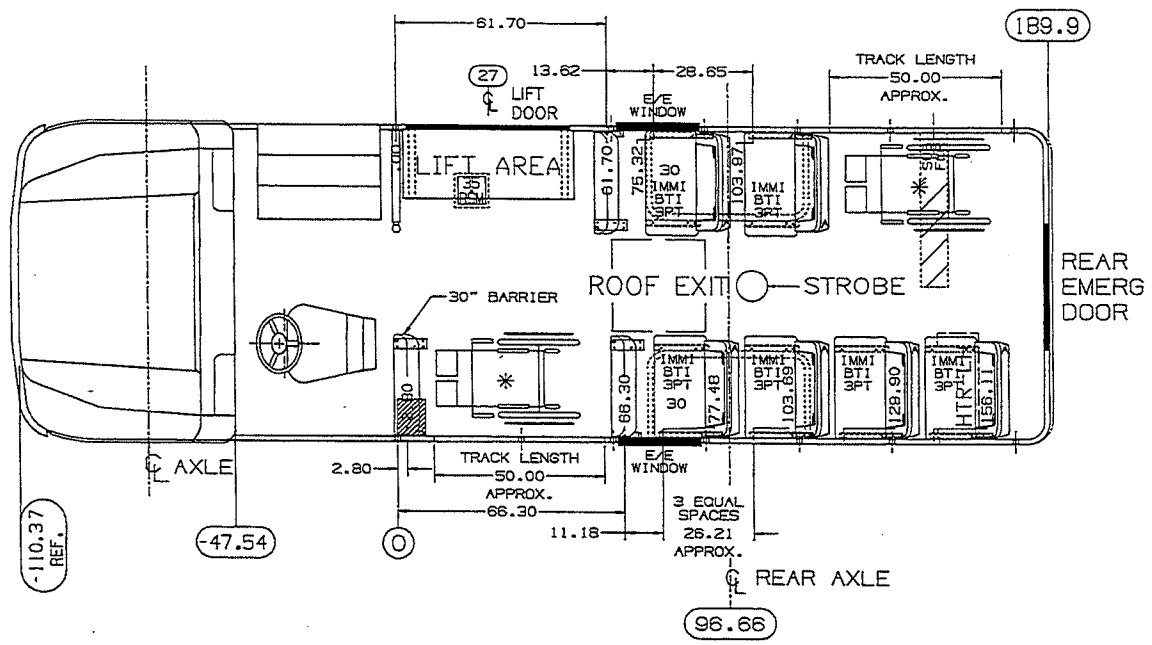

\* NOTE: SEE SHEET 2 & 3 FOR WC-TRACK INSTALLATION

PURCHASED SEATS IN THIS UNIT ARE: BTI (3P)

\* 100": TOTAL TRACK LENGTH (APPROXIMATELY)

\* NOTE: IT IS THE SELLING DEALER'S RESPONSIBILITY TO ENSURE THAT ANY WHEELCHAIR TIE-DOWN SYSTEM SPECIFIED AND DEPICTED ON THIS DRAWING MEETS ALL DESTINATION STATE SPECIFICATIONS AND TO ALSO ENSURE THAT THE WHEELCHAIRS CAN BE PLACED AND REMOVED WITH RESPECT TO: SEATS, K/O'S, SIDE EMERG DOORS, HEATERS, LIFTS, WHEELHOUSES, ETC. POSSESSION OF THIS PRINT DOES NOT IN ANY WAY OBLIGATE IC CORP. TO BUILD THE UNIT SHOWN. WC TRACK SHOWN IS FOR REFERENCE ONLY.

THIS UNIT CONFORMS TO APPLICABLE FMVSS

THIS DOCUMENT IS IN ACCORDANCE WITH 48CFR 101-11.6-100 AS ISSUED BY THE INTERNATIONAL TRADE DEVELOPMENT ADMINISTRATION AND TELEMARKING ASSOCIATION-2000.

REV	DATE	DESCRIPTION	BY	REFERENCE
MAC23	JAN20	11.18 WAS 11.62, 28.21 WAS 128.65, 77.48 WAS 77.92, 103.69 WAS 104.57, 128.90 WAS 131.22, 156.11 WAS 157.87		
MAC02	DEC23	NOT AFFECTED. SEE SH 316		

### AT A GLANCE

**ENGINE- CUMMINS**

**FUEL TYPE- DIESEL**

**HP- 220**

**TRANS- ALLISON 2500PTS**

**SIZE- 34 LIFT**

**CAPACITY- 14**

**WHEELBASE- 170"**

**ITEM # IC-01**

**INTERNATIONAL TRUCK AND ENGINE CORPORATION**

**INTERNATIONAL CONFIDENTIAL PROPRIETARY**

REFERENCE: BLUE-158

LINEAR MEASURE:  IN  IN

APPROX. MASS (WEIGHT) ROUGH PART

FINISH PART

DATE: BODY PLAN PB10500

SCALE: E 50

DESIGNER: ISLANIS

DATE:

REVISED BY: DATE: PART TYPE: DATE: SCALE: 4

DATE: PART NO: DATE: SCALE: 01

DJ0295A001

50WEV/49001

REVISE ONLY ON 48CFR SYSTEM



LEFT SIDE ABOVE FLOOR OR LOW PROFILE ABOVE FLOOR OR BELOW FLOOR FUEL FILL OPTIONS NOT AVAILABLE

RSM TANK OPTION WILL REDUCE SERVICEABILITY OF SENDING UNIT.

VERTICAL HINGED E/E REQUIRED

BODY PLAN

WHEELBASE 218"

PB10500, 26 FT. 8 IN., CAP 20, SEAT SIZE 30/30, SEAT SPACING VARIES, LIFT-FRONT, 4-WC

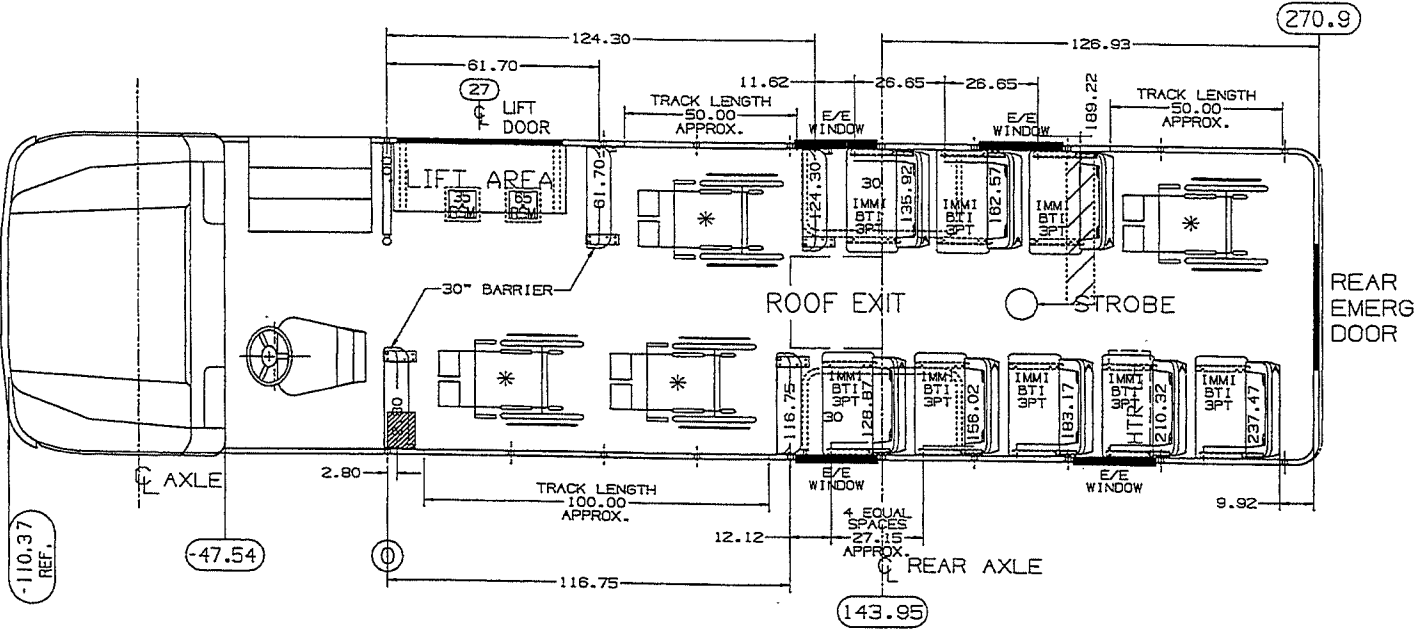

\* NOTE: SEE SHEET 2 & 3 FOR WC-TRACK INSTALLATION

PURCHASED SEATS IN THIS UNIT ARE: BTI (3P)

\* 200" : TOTAL TRACK LENGTH (APPROXIMATELY)

\* NOTE: IT IS THE SELLING DEALER'S RESPONSIBILITY TO ENSURE THAT ANY WHEELCHAIR TIE-DOWN SYSTEM SPECIFIED AND DEPICTED ON THIS DRAWING MEETS ALL DESTINATION STATE SPECIFICATIONS AND TO ALSO ENSURE THAT THE WHEELCHAIRS CAN BE PLACED AND REMOVED WITH RESPECT TO SEATS, K/O'S, SIDE EMERG DOORS, HEATERS, LIFTS, WHEELHOUSES, ETC.. POSSESSION OF THIS PRINT DOES NOT IN ANY WAY OBLIGATE IC CORP. TO BUILD THE UNIT SHOWN. WC TRACK SHOWN IS FOR REFERENCE ONLY.

THIS UNIT CONFORMS TO APPLICABLE FMVSS

THIS DOCUMENT IS IN ACCORDANCE WITH ASME Y14.5-1994 AND ANSI Z39.5-1994 DIMENSIONING AND TOLERANCING ACCORDING TO ASME Y14.5-1994

**AT A GLANCE**

ENGINE- CUMMINS or PSI  
 FUEL TYPE- DIESEL OR PROPANE  
 HP- ALL  
 TRANS- 2,500 PTS  
 SIZE- 52 LIFT  
 CAPACITY- 20  
 WHEELBASE- 218"  
 ITEM # IC-03, IC-02, IC-08

50VXD/49001

INTERNATIONAL TRUCK AND ENGINE CORPORATION		INTERNATIONAL CONFIDENTIAL PROPRIETARY	
REFERENCE BLUE-159		APPROX. MASS (WEIGHT)	
LINEAR MEASUREMENT	IN	MM	FINISH PART
ONE PLACE	1.30	±0.25	±0.03
TWO PLACE	1.300	±0.08	±0.03
THREE PLACE	1.3000	±0.025	±0.010
AXIS	4"		
BODY PLAN PB10500		E 50	
LUDOMACH		INTERNAL CONTROL	
22AUS19		E	
DATE		DATE	
PART NAME		PART TYPE	
DATE		DATE	
DRAWING NO.		REV. NO.	
DJO140A001		01	

LEFT SIDE ABOVE FLOOR OR LOW PROFILE ABOVE FLOOR OR BELOW FLOOR FUEL TANK OPTIONS NOT AVAILABLE

SAL. RES. TANK OPTION WILL REDUCE SERVICEABILITY OF SENDING UNIT.

**BODY PLAN**

WHEELBASE 276"

PB10500, 33 FT. 5 IN., CAP 30, SEAT SIZE 30/30, SEAT SPACING VARIES, LIFT-FRONT, 4-WC, SIDE EMERG DOOR

**AT A GLANCE**

ENGINE-CUMMINS OR PSI  
 FUEL TYPE-DIESEL OR PROPANE  
 HP- ALL  
 TRANS- ALL-2500PTS OR 3000PTS  
 SIZE- 66  
 CAPACITY- 30  
 WHEELBASE- 276"  
 ITEM# IC-04, IC-05, IC-06

IC-07, IC-09

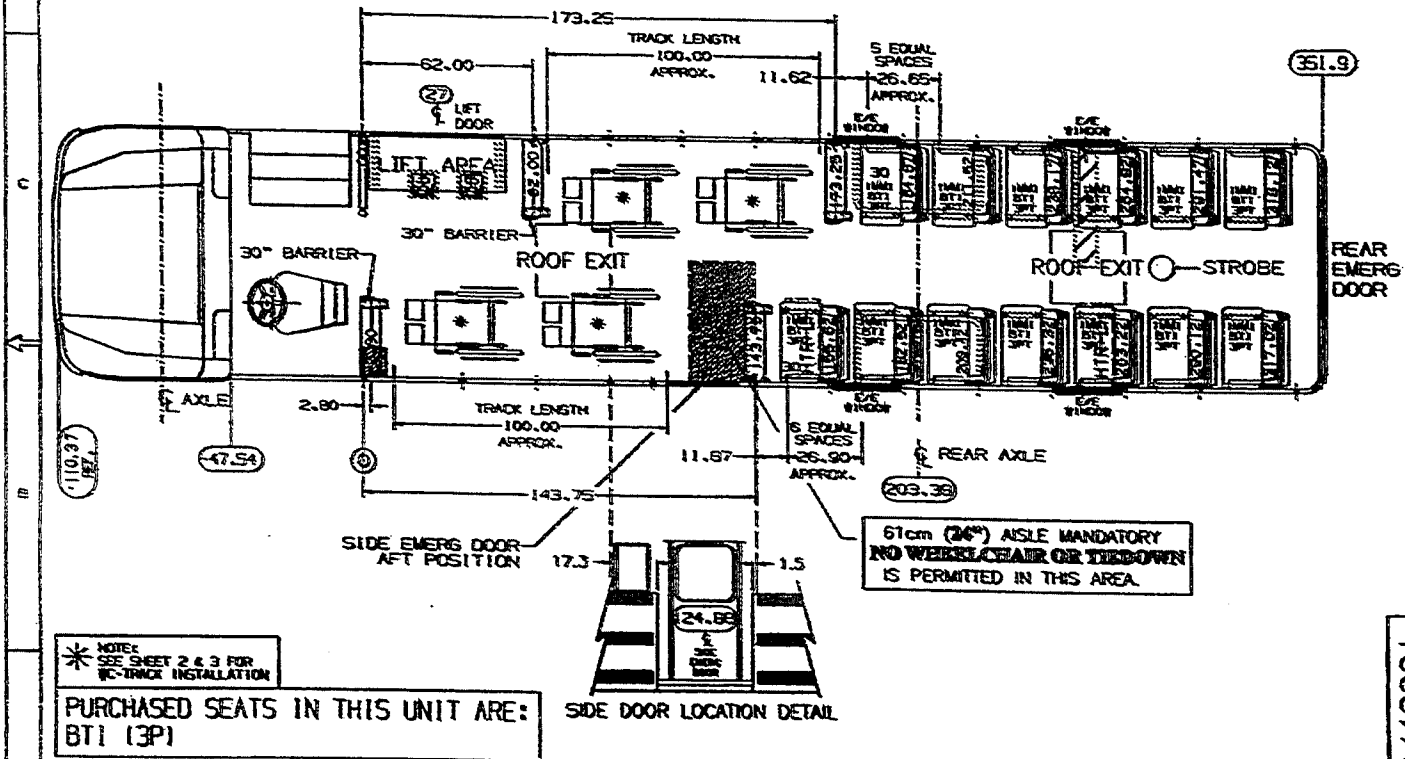

\* NOTE: SEE SHEET 2 & 3 FOR WC-TRACK INSTALLATION

PURCHASED SEATS IN THIS UNIT ARE: BT1 (3P)

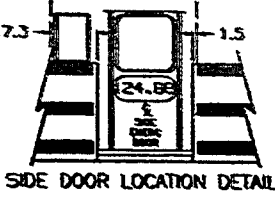

61cm (24") AISLE MANDATORY NO WHEELCHAIR OR TIEDOWN IS PERMITTED IN THIS AREA.

\* 200" : TOTAL TRACK LENGTH (APPROXIMATELY)

\* NOTE: IT IS THE SELLING DEALER'S RESPONSIBILITY TO ENSURE THAT ANY WHEELCHAIR TIE-DOWN SYSTEM SPECIFIED AND DEPICTED ON THIS DRAWING MEETS ALL DESTINATION STATE SPECIFICATIONS AND TO ALSO ENSURE THAT THE WHEELCHAIRS CAN BE PLACED AND REMOVED WITH RESPECT TO SEATS, K/V'S, SIDE EMERG DOORS, HEATERS, LIFTS, WHEELHOUSES, ETC. POSSESSION OF THIS PRINT DOES NOT IN ANY WAY OBLIGATE IC CORP. TO BUILD THE UNIT SHOWN. WC TRACK SHOWN IS FOR REFERENCE ONLY.

THIS UNIT CONFORMS TO APPLICABLE FINVSS

50WCC/49001

INTERNATIONAL TRUCK AND ENGINE CORPORATION	
INTERNATIONAL TRUCK AND ENGINE CORPORATION	
ORDER NO.	DATE ORDERED
QUANTITY	QUANTITY ORDERED
UNIT PRICE	TOTAL PRICE
BODY PLAN PB10500	
IC 30	
DJ0238A001	

LEFT SIDE ABOVE FLOOR OR  
LOW PROFILE ABOVE FLOOR OR  
BELOW FLOOR FUEL FILL  
OPTIONS NOT AVAILABLE

BODY PLAN

WHEELBASE 170"

PB10500, 19 FT. 11 IN., CAP 34, SEAT SIZE VARIES, SEAT SPACING 27.99

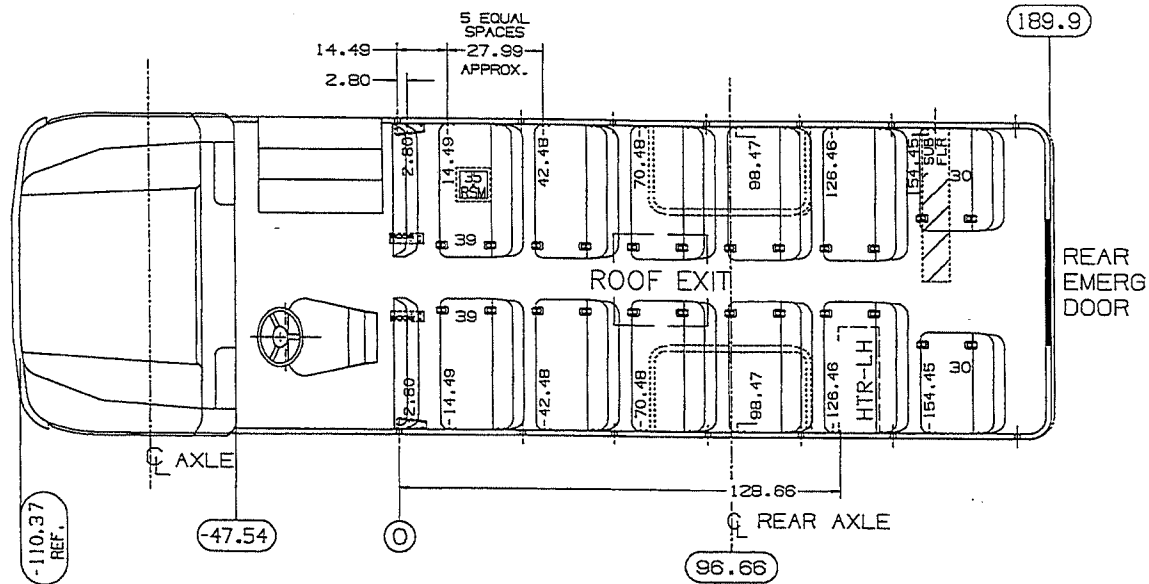

### AT A GLANCE

ENGINE- CUMMINS  
 FUEL TYPE- DIESEL  
 HP- 226  
 TRANS- Allison 2500PTS  
 SIZE- 34  
 CAPACITY- 34  
 WHEELBASE- 170  
 ITEM # IC-10

50PSJ/49002

INTERNATIONAL TRUCK AND ENGINE CORPORATION  
 INTERNATIONAL CONFIDENTIAL PROPRIETARY

REFERENCE: DX7841A000

LINEAR MEASURE:	mm	in	APPROX. MASS (WEIGHT)	
UNLESS SPECIFIED ON TELEPHONE OR			ROUGH PART	
			FINISH PART	

ONE PLACE (1.0) 1/16 1/16 4.08 1/16 INTERNAL CONTROL

TWO PLACE (1.00) 1/32 1/32 0.8 1/32

THREE PLACE (1.000) 1/64 1/64 0.10 1/64

FOUR PLACE (1.0000) 1/256 1/256 0.01 1/256

FINISH PART: BODY PLAN PB10500

REVISIONS:

NO.	DATE	DESCRIPTION
1	10222223	
2	13-JAN-21	

THIS UNIT CONFORMS TO APPLICABLE FMVSS

THIS DOCUMENT IS IN ACCORDANCE WITH ASME Y14.5-2018  
 AS AMENDED BY THE INTERNATIONAL TRUCK ENGINEERING  
 DIMENSIONING AND TOLERANCING ASSOCIATION (IETD)

DX7841A002

LEFT SIDE ABOVE FLOOR OR  
LOW PROFILE ABOVE FLOOR OR  
BELOW FLOOR FUEL FILL  
OPTIONS NOT AVAILABLE

**BODY PLAN**

WHEELBASE 218"

PB10500, 26 FT. 8 IN., CAP 52, SEAT SIZE 39/39, SEAT SPACING 27.70

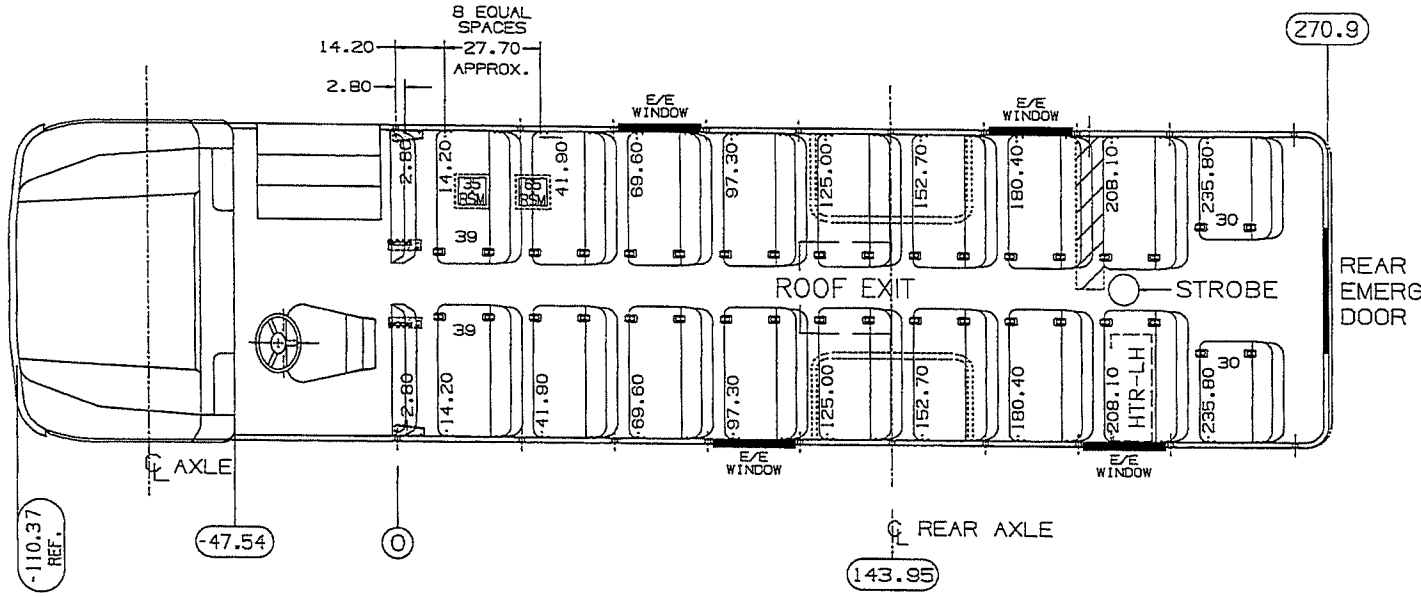

DATE	BY	REVISION	DESCRIPTION
11/14/08	JANIE	1	UPDATE TO U8-ADD BTR NOTE
12/17/08	DEC	2	UPDATED CSRS PICTORIAL. IF
1/14/09	JANIE	3	BARRIERS: ADDED 3SRM BLOCK; RELOCATED BTR BLOCK. DIM TEXT FOR CLARITY. 143.95 WAS
1/14/09	JANIE	4	27.70 IN TOP DESCRIPTION WAS 27.7

### AT A GLANCE

ENGINE: ~~COMMIN~~ OR *PSI*  
 FUEL TYPE: ~~DIESEL~~ OR *PROPANE*  
 HP: ~~ALL~~ OR *ELECTRIC*  
 TRANS: *2500PTJ*  
 SIZE: *S2*  
 CAPACITY: *52*  
 WHEELBASE: *218"*  
 ITEM # *IC-11, IC-12,*

*IC-21, IC-24*

49TMZ/49001			INTERNATIONAL TRUCK AND ENGINE CORPORATION	
	INTERNATIONAL CONFIDENTIAL PROPRIETARY			
	REFERENCE	493393013	APPROX. MASS (WEIGHT)	
	LINEAR MEASURE	<input type="checkbox"/> IN <input checked="" type="checkbox"/> IN	ROUND PART	
ONE PLACE	0.01	0.05	0.00	INTERNAL CONTROL
TWO PLACE	0.00	0.01	0.00	
THREE PLACE	0.000	0.001	0.010	
FINISH PART				
NAME	BODY PLAN PB10500			WEIGHT
REVISE ONLY ON				REVISE ONLY ON
U80VAF2				U80VAF2
14MAY99				14MAY99
DATE		DATE		DATE
APPROVED		APPROVED		APPROVED
DATE		DATE		DATE
DATE		DATE		DATE
DATE		DATE		DATE

THIS UNIT CONFORMS TO APPLICABLE FMVSS  
 THIS DOCUMENT IS IN ACCORDANCE WITH ASME Y14.5M-1994  
 AS INDICATED BY THE INFORMATIONAL TRUCK DIVISION  
 DIMENSIONING AND TOLERANCING ADDENDUM-2000.

DX0166A001

DIESEL LEFT SIDE FUEL FILL OPTION CANNOT BE USED WITH THIS BODY PLAN.

BODY PLAN

WHEELBASE 276"

PB10500, 33 FT. 5 IN., CAP 66, SEAT SIZE 39/39, SEAT SPACING VARIES, SIDE EMERG DOOR

MACROVIEW REMOVED PROPANE NOTED  
 UPDATED STR BLOCKY ADDED STR NOTED  
 RELOCATED STR BLOCK. DIM TEXT FOR CLARITY

### AT A GLANCE

ENGINE- PSI  
 FUEL TYPE- PROPANE  
 HP- 270  
 TRANS- 2500PTS  
 SIZE- 66  
 CAPACITY- 66  
 WHEELBASE- 276"  
 ITEM # IC-22

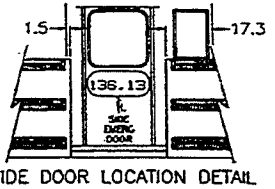
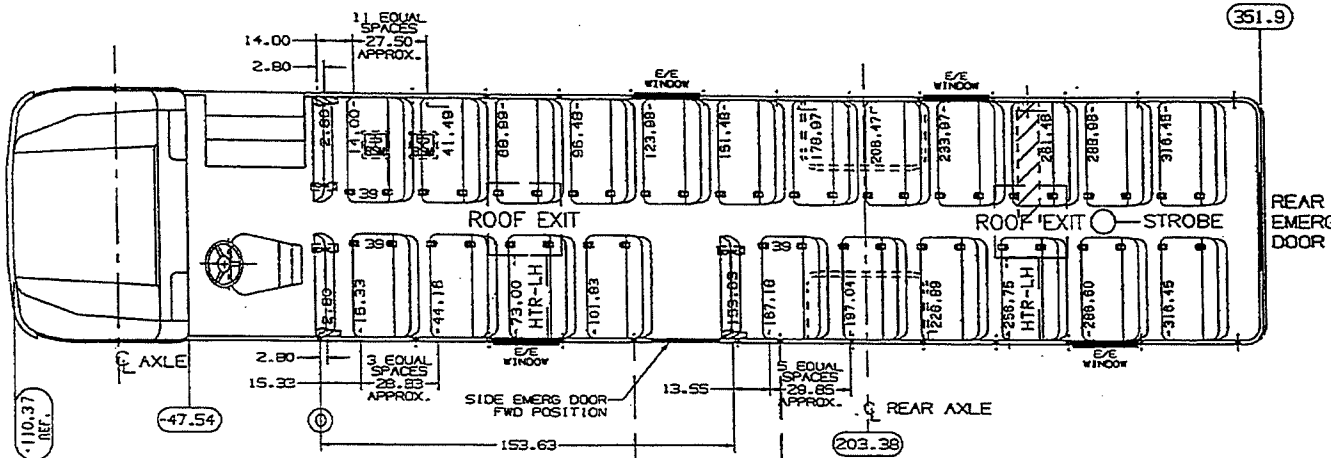

THIS UNIT CONFORMS TO APPLICABLE FMVSS

SORTN/49001

INTERNATIONAL TRUCK AND ENGINE CORPORATION INTERNATIONAL CONFIDENTIAL PROPRIETARY		MODEL	BLUE-122
		APPROX. HOSE LENGTH	
LINEAR MEASURED	IN	FT	
IN PLACE	LBS		
TIME IN PLACE	HRS		
PRICE			
BODY PLAN PB10500		E 50	
REVISE ONLY ON 49001		REVISE ONLY ON 49001	
DATE		DATE	
BY		BY	
CHKD BY		CHKD BY	
DX8226A001			

LEFT SIDE FUEL FILL  
OPTION CANNOT BE USED  
WITH THIS BODY PLAN.

BODY PLAN

WHEELBASE 276"

PB10500, 32 FT. 8 IN., PLUS 9 RR., CAP 66, SEAT SIZE 39/39, SEAT SPACING VARIES, SIDE EMERG DOOR

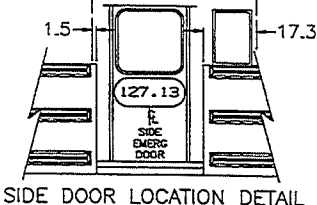
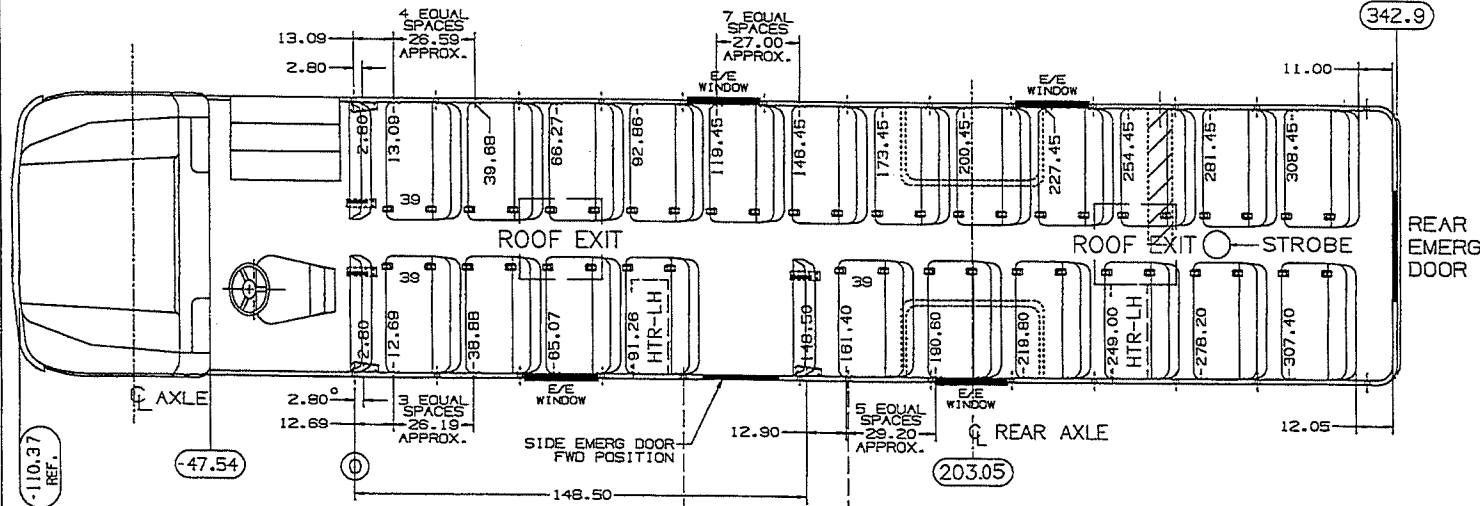

**AT A GLANCE**

ENGINE CUMMINS  
FUEL TYPE DIESEL  
HP: ALL  
TRANS- 2500PTS OR 3000PTS  
SIZE- 66  
CAPACITY- 66  
WHEELBASE- 276"  
ITEM # IC-13, IC-14, IC-17,

IC-18,

49TCG/49001

		INTERNATIONAL TRUCK AND ENGINE CORPORATION	
		INTERNATIONAL CONFIDENTIAL PROPRIETARY	
REFERENCE	493595011		
LINEAR MEASURE	<input type="checkbox"/> IN	<input checked="" type="checkbox"/> MM	APPROX. MASS (WEIGHT)
FINISH PART	ROOF PART		
ONE PLACE	1.30	0.15	0.05
TWO PLACE	1.300	0.15	0.05
THREE PLACE	1.3000	0.15	0.05
AXLE	4"		
MODEL	BODY PLAN PB10500		
DATE	E 50		
REVISION	1000MS7		
DATE	05MAY89		
DATE	PART NO. 4		
DATE	PART NO. 01		

THIS UNIT CONFORMS TO APPLICABLE FMVSS

THIS DOCUMENT IS IN ACCORDANCE WITH ASME Y14.3M-1994 AS APPROVED BY THE INTERNATIONAL TRADE UNION DIMENSIONING AND TOLERANCING ASSOCIATION-2000.

DX0026A001

LEFT SIDE FUEL FILL OPTION CANNOT BE USED WITH THIS BODY PLAN.

**BODY PLAN**

WHEELBASE 276"

PB10500, 34 FT. 2 IN., CAP 72, SEAT SIZE 39/39, SEAT SPACING VARIES, SIDE EMERG DOOR

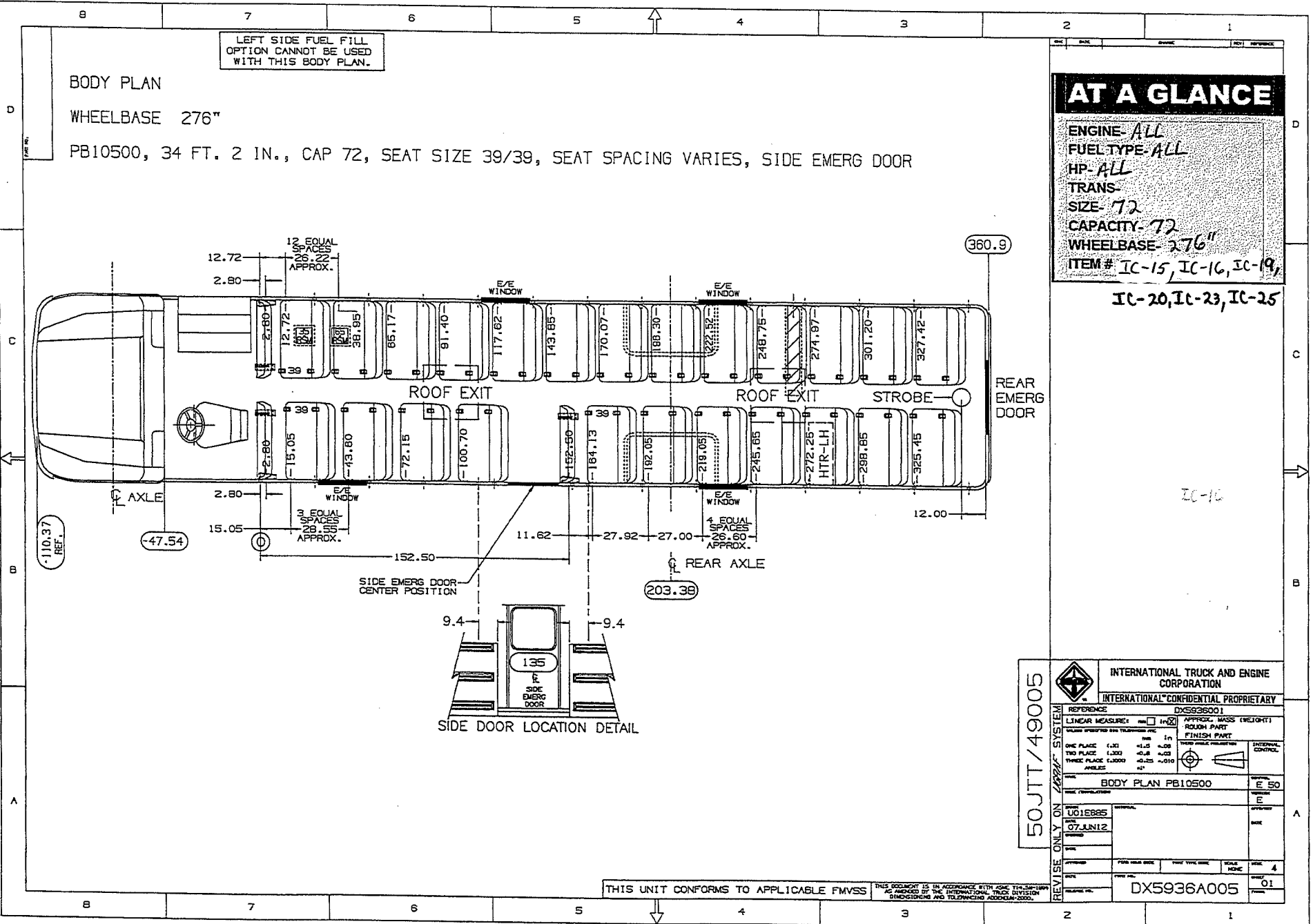

**AT A GLANCE**

ENGINE- ALL  
 FUEL TYPE- ALL  
 HP- ALL  
 TRANS-  
 SIZE- 72  
 CAPACITY- 72  
 WHEELBASE- 276"  
 ITEM # IC-15, IC-16, IC-19,

IC-20, IC-23, IC-25

IC-16

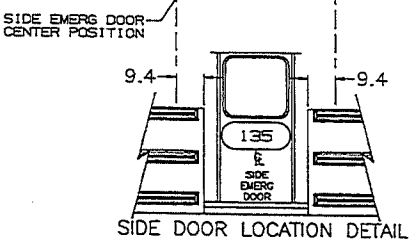

50JTT/49005

INTERNATIONAL TRUCK AND ENGINE CORPORATION	
INTERNATIONAL CONFIDENTIAL PROPRIETARY	
REFERENCE	DXS938001
LINEAR MEASURE	APPROX. MASS (WEIGHT)
ONE PLACE 1,300	~1.5
TWO PLACE 1,300	~2.8
THREE PLACE 1,300	~4.2
ANGLE	4°
TITLE	BODY PLAN PB10500
DATE	07JUN12
REVISED	01
APPROVED	DXS936A005

THIS UNIT CONFORMS TO APPLICABLE FMVSS

THIS DOCUMENT IS IN ACCORDANCE WITH ASME Y14.100-2018 AS AMENDED BY THE INTERNATIONAL TRUCK DIVISION DIMENSIONING AND TOLERANCING ADDENDUM-2009.



**KENTUCKY DEPARTMENT OF EDUCATION  
2023 THOMAS SCHOOL BUS PURCHASE AUTHORIZATION**

The Board of Education \_\_\_\_\_, Kentucky, on \_\_\_\_\_, 20\_\_\_\_, in a legally called and constituted meeting, did vote to purchase school buses through the Kentucky State Contract price procedure.

This Board of Education took this official action in order to authorize the Chief State School Officer to procure 2023 school buses. This action, as spread upon the minutes of the meeting of this Board of Education on the above date, should be construed as evidence of obligation of this Board of Education to purchase the above school buses through State Price Contract agreements established in accordance with statutory authority.

Signed

\_\_\_\_\_, Secretary  
\_\_\_\_\_, Superintendent  
Of \_\_\_\_\_, Board of Education  
Date \_\_\_\_\_.

**BODY SIDE NUMBERS:** Indicate the body side number the Board of Education wants painted on the body side of each school bus. Match body side number to individual item numbers. Example: Item 1 - Side number - 5, 6, 7, 8

---



---



---



---

**DUE TO SUPPLY CHAIN ISSUES, CURRENT LEAD TIMES FOR BUS COMPLETION IS 240-270 DAYS.**

ATTACH ADDITIONAL INFORMATION IF NECESSARY







**2023 Thomas Bus Purchase Authorization**  
**BOARD OF EDUCATION**



**Type C Electric**

Item #	Quantity	Bus Type	Capacity	Engine	Chassis	HP	Transmission	Wheel Base	Rear Axle	Base Price
TH14		C	66	Proterra	Freightliner	161	Eaton	279	149	\$414,668
TH15		C	72	Proterra	Freightliner	161	Eaton	279	149	\$415,128

**Type D Diesel**

Item #	Quantity	Bus Type	Capacity	Engine	Chassis	HP	Transmission	Wheel Base	Rear Axle Overhang	Base Price
TH16		D / FC	70	Cummins	Freightliner	260	Allison	212	156	\$140,124
TH17		D / FC	74	Cummins	Freightliner	260	Allison	212	156	\$141,202
TH18		D / FC	78	Cummins	Freightliner	260	Allison	231	155	\$143,478
TH19		D / RE	78	Cummins	Freightliner	240	Allison	267	115	\$148,935
TH20		D / RE	84	Cummins	Freightliner	280	Allison	267	115	\$153,600

**RADIO**

Option	Bus Type	Option	Extended Description	Price
THO1	C & D	Radio	Page System Only - No Radio	\$690
THO2	C	Radio	Delphi AM/FM Radio with Flush-Mounted Speakers (No Page)	\$720
THO3	C	Radio	Delphi AM/FM Radio with Flush-Mounted Speakers, Outside Speaker w/ Page, Chassis Mounted	\$815
THO4	D	Radio	Delphi AM/FM Radio with Flush-Mounted Speakers (Type D ER/Forward Control 70 - 84) (No Page)	\$815
THO5	D	Radio	Delphi AM/FM Radio with Flush-Mounted Speakers, Outside Speaker, Chassis Mounted (Type D ER And FC 70 - 84) PA	\$940

**CAMERA**

Option	Bus Type	Option	Extended Description	Price
THO6	C	Camera	Meritor- Wabco ONGuard Active Collision Avoidance System Allows collision warning, active braking and adaptive cruise control at forward speeds 15 MPH and above. System provides audible, haptic and visual warnings to alert drivers to possible traffic obstructions. Radar technology provides ability to detect potential collision conditions up to 650 feet forward of the vehicle. Avoidance system allows intervention including active braking and throttle reduction to reduce chance of impending collisions. Adaptive cruise control feature utilizes radar to assist with safe following distances from other vehicles. System maintains set speed when lane is clear and automatically adjusts vehicle speed to maintain a set time interval between the system	\$2500
THO7	All Buses	Camera	Backup Camera - Interior Mirror	\$1125
THO8	C	Camera	Bus Wise - Mobileye Collision Avoidance	\$1100
THO9	C	Camera	Bus Wise - Perimeter View 360 Camera - C2 Buses	\$2375
THO10	D	Camera	Bus Wise - Perimeter View 360 Camera - EFX&HDX	\$2575
THO11	C	Camera	Bus Wise WIFI Router - Wireless Networking Hardware. Expands Capacity of Customer Supplied Wireless Hotspot	\$395
THO12	All Buses	ProVision Camera	DVR-908LP1-128 - Pro-Vision Titan, 1080P High Definition Solid State DVR, (1) Low profile 1080P HD Camera, Passive GPS,Event Marker Button, Power Harness, Playback Software, 128gb SDXC, Health Alert Dashboard. 5 Year warranty	\$1100
THO13	All Buses	ProVision Camera	DVR-908LP1-256 - Pro-Vision Titan, 1080P High Definition Solid State DVR, (1) Low profile 1080P HD Camera, Passive GPS,Event Marker Button, Power Harness, Playback Software, 256gb SDXC, Health Alert Dashboard. 5 Year warranty	\$1,200

THO14	All Buses	ProVision Camera	DVR-908LP2-128 - Pro-Vision Titan, 1080P High Definition Solid State DVR, (1) Low profile 1080P HD Camera, Passive GPS,Event Marker Button, Power Harness, Playback Software, 128gb SDXC, Health Alert Dashboard. 5 Year warranty	\$1325
THO15	All Buses	ProVision Camera	DVR-908LP2-256 - Pro-Vision Titan, 1080P High Definition Solid State DVR, (1) Low profile 1080P HD Camera, Passive GPS,Event Marker Button, Power Harness, Playback Software, 256gb SDXC, Health Alert Dashboard. 5 Year warranty	\$1425
THO16	All Buses	ProVision Camera	DVR-908LP3-128 - Pro-Vision Titan, 1080P High Definition Solid State DVR, (1) Low profile 1080P HD Camera, Passive GPS,Event Marker Button, Power Harness, Playback Software, 128gb SDXC, Health Alert Dashboard. 5 Year warranty	\$1550
THO17	All Buses	ProVision Camera	DVR-908LP3-256 - Pro-Vision Titan, 1080P High Definition Solid State DVR, (1) Low profile 1080P HD Camera, Passive GPS,Event Marker Button, Power Harness, Playback Software, 256gb SDXC, Health Alert Dashboard. 5 Year warranty	\$1,650
THO18	All Buses	ProVision Camera	DVR-908LP4-128 - Pro-Vision Titan, 1080P High Definition Solid State DVR, (1) Low profile 1080P HD Camera, Passive GPS,Event Marker Button, Power Harness, Playback Software, 128gb SDXC, Health Alert Dashboard. 5 Year warranty	\$1750
THO19	All Buses	ProVision Camera	DVR-908LP4-256 - Pro-Vision Titan, 1080P High Definition Solid State DVR, (1) Low profile 1080P HD Camera, Passive GPS,Event Marker Button, Power Harness, Playback Software, 256gb SDXC, Health Alert Dashboard. 5 Year warranty	\$1850
THO20	All Buses	ProVision	PRO-VISION DVR-912 - Pro-Vision AHD Low Profile Waterproof Camera Kit - Exterior Camera	\$295
THO21	All Buses	ProVision	PRO- VISION DVR-920 - Pro-Vision AHD Waterproof Side Camera - Exterior Camera	\$295
THO22	All Buses	ProVision	PRO-VISION DVR-921 - Pro-Vision AHD Mini Dome Camera Kit	\$295
THO23	All Buses	ProVision	PRO-VISION DVR-922 -Pro-Vision AHD Dash Camera - (windshield mounting)	\$380
THO24	All Buses	ProVision	ProVision DVR-923 -Pro-Vision AHD Ultra Wide Low Profile Camera	\$295
THO25	All Buses	ProVision	ProVision DVR-824 - Pro-Vision 1080P High Definition Dual Facing Stop Arm Camera	\$850
THO26	All Buses	ProVision	ProVision PX-1943 - 30' Camera Cable / 10m	\$35
THO27	All Buses	ProVision	ECB-1yr -ProVision Wireless Transfer Kit - 1 Year	\$100
THO28	All Buses	ProVision	ECB -3yr -ProVision Wireless Transfer Kit - 3 Year	\$280
THO29	All Buses	ProVision	ECB -5yr -ProVision Wireless Transfer Kit - 5 Year	\$420
THO30	All Buses	ProVision	ProVision 128GB Card- DVR-728	180
THO31	All Buses	ProVision	ProVision 256GB Card - DVR-738	\$320

THO32	All Buses	ProVision	ProVision DVR-830 - 500GB Solid State Drive, Compatible with ProVision System	\$400
THO33	All Buses	ProVision	ProVision DVR-831 - 1 TB Solid State Drive, Compatible with ProVision System	\$545
THO34	All Buses	ProVision	PRO-VISION -DVR-802 - Solid State Drive Reader	\$50
THO35	All Buses	ProVision	Installation for Basic System at Boyd Facility (Includes 1 Camera Head)	\$495
THO36	All Buses	ProVision	Installation for Each Additional Camera Head	\$150
THO37	All Buses	SEON Camera - SD	DH4C 128 - Seon Solid State DVR, 4 HD Channels, Audio, WIFI, G Sensor, Mounting Plate, Power Harness, 128gb Sd Card, No Camera Heads Included	\$800
THO38	All Buses	SEON Camera - HD System	Dh4 - Seon DVR, 4 HD Channels, Audio, WIFI, Security Front Locking Cover, Mnt Plate, Power Harness, 500gb Hard Drive - No Camera Heads Included	\$1000
THO39	All Buses	SEON Camera - HD	DH6- SEON DVR, 6 HD Channels, AUDIO, GPS + Antenna, WIFI, 6 CH Breakout Harness w/ 2X3 Video Connectors, Security Locking Front Cover, Mnt Plate, Power Harness, 500 GB Hard Drive- No Camera Heads	\$1500
THO40	All Buses	SEON Camera - HD	DH8 - SEON DH8 DVR, 8 HD Channel, Audio,GPS + Antenna, WIFI, 8CH Breakout Harness w/ 2X3 Video Connectors, Security Locking Front Cover, Mnt Plate, Power Harness, 1 TB Hard Drive- No Camera Heads Included	\$1900
THO41	All Buses	SEON	WT2E20S20G6 - Wire Bundle W/ Harness, RGY Button AND 20 FT Cable, 5 Signal Inputs 20 FT, GPS Antenna Magnetic Mount for DH4C OR DH4 USE THIS	\$160
THO42	All Buses	SEON	WT2E20S20G0 – Wire Bundle w/ Harness, RGY Button and 20 FT Cable, 5 Signal Inputs 20 FT, No GPS Antenna for DVR DH6 or DH8 USE THIS	\$160
THO43	All Buses	SEON	HD1QXXAI20 - HD 720P Camera, Dome, pick a Lense Size 2.6, 3.6 OR 6.0mm, 20' harness -For Use w/ DH or Older TH Series Systems	\$310
THO44	All Buses	SEON	HD1QXXAI50 - HD 720P Camera, Dome, pick a Lense Size 2.6, 3.6 OR 6.0mm, 50' harness -For Use w/ DH or Older TH Series Systems	\$325
THO45	All Buses	SEON	HD1QXXAI75 - HD 720P Camera, Dome, pick a Lense Size 2.6, 3.6 OR 6.0mm, 75' harness - For Use w/ DH or Older TH Series Systems	\$350
THO46	All Buses	SEON	HD3U01N20 180 degree head -- w/ 20' Harness - for all DH systems and TH6	\$350
THO47	All Buses	SEON	HD3U01N50 180 degree head -- w/ 50' Harness - for all DH systems and TH6	\$380
THO48	All Buses	SEON	HD3U01N75 180 degree head -- w/ 75' Harness - for all DH systems and TH6	\$400
THO49	All Buses	SEON	HD3S16EI20-HD Stop Arm Cameras, 16mm External, 20' harness	\$500
THO50	All Buses	SEON	CHQ-MP6A30 - Mounting Post. 6", 30%	\$75
THO51	All Buses	SEON	TH-HK500G - H Series 500GB Hard Drive - For DH4/DH6	\$275

## Thomas Buses

THO52	All Buses	SEON	TH8-HK1T0 - H Series - 1TB Hard Drive, Double Wide - For DH8	\$400
THO53	All Buses	SEON	HDIA20 - Event Button, 5' With 20 ' EXT	\$85
THO54	All Buses	SEON	HDD3-STB - Reader Dock with Trackball Software (NEW CUSTOMER ONLY)	\$395
THO55	All Buses	SEON	HDD-DOCK3 - Reader Dock Only, No Software, No	\$310
THO56	All Buses	SEON	SRLA07 - Smart Reach Lite, 2.4 GHz, Stand Antenna 6' Cable & Poe Adaptor	\$595
THO57	All Buses	SEON	LMK - LCD Monitor	\$390
THO58	All Buses	SEON	Installation for Basic System At Boyd Facility (Includes 1 Camera Head)	\$495
THO59	All Buses	SEON	Installation for Each Additional Camera Head	\$150

**LUGGAGE (see chart for compatibility)**

Option	Bus Type	Option	Extended Description	Price
THO60	C	Luggage	Storage Boxes (TYPE C) - 34 Passenger - 72 Passenger - 30 Inches Wide (LS or RS)	\$530
THO61	C	Luggage	Storage Boxes (TYPE C) - 52 Passenger - 72 Passenger - 60 Inches Wide (LS or RS)	\$1,070
THO62	C	Luggage	Storage Boxes (TYPE C) - 66 Passenger - 72 Passenger - 100 Inches Wide (LS or RS)	\$1425
THO63	D / FC	Luggage	Storage Boxes (TYPE D FC) 70-78 Passenger - 60" (LS or	\$1225
THO64	D / FC	Luggage	Storage Boxes (TYPE D FC 78 Passenger - 100" (LS or	\$1,465
THO65	D/RE	Luggage	Storage Boxes (TYPE D RE) 78-84 Passenger - 60" (LS or	\$1,225
THO66	D / RE	Luggage	Storage Boxes (TYPE D RE 84 Passenger - 100" (LS or	\$1685
THO67	D / RE	Luggage	Storage Boxes (TYPE D RE) 78-84 Passenger - Center Pass Thru - Includes Gas Springs	\$4,875

**AIR CONDITIONING**

Option	Bus Type	Option	Extended Description	Price
THO68	C - 34 Shell Bus	A/C	Type C Air Conditioning System, 34 Passenger Shell Size, 85,000 BTU System (C2)	\$8,795
THO69	C	A/C	Type C Air Conditioning System, 52-72 Passenger Shell Size, 126,000 BTU SYSTEM (C2) - With Dash Air	\$12,800
THO70	C	A/C	Type C-Dash Air Only (Except 34 Shell) (EV JOULEY BUS-Dash Air is Standard)	\$2,875
THO71	D	A/C	A/C SYSTEM, 70-84 Passenger Shell Size, 120,000 BTU System	\$13,400
THO72	All Buses Except 34 Shell	A/C - W/ Roof Mounted	Full Air Conditioning System w/ Roof Condenser Instead of Skirt Condenser	\$16,000

**TIRES**

Option	Bus Type	Option	Extended Description	Price
THO73	C	TIRES	14 PLY TO 16 PLY - (THOMAS BUS COMES STANDARD WITH MICHELIN TIRES)	\$490

**HORSE POWER UPGRADE**

## Thomas Buses

Option	Bus Type	Option	Extended Description	Price
THO74	C	HP Upgrade	200 TO 220HP	\$620
THO75	C	HP Upgrade	220 TO 250HP	\$1,220
THO76	D/ RE	HP Upgrade	240 TO 260HP	\$1220
THO77	D/ RE & FC	HP Upgrade	260 TO 280HP	\$1,375
THO78	C	HP Upgrade	DD5 Detroit 240 HP Engine	\$2,250
THO79	D	HP Upgrade	DD8 Detroit 280 HP Engine	\$5,900

**WARRANTY**

Option	Bus Type	Option	Extended Description	Price
THO80	All Buses	Warranty	Tow Warranty- 150K	\$1,850
THO81	All Buses	Warranty	Tow Warranty-Unlimited	\$2,250

**SEATING**

Option	Bus Type	Option	Extended Description	Price
THO82	C	Seats	Add 1 30" S3C Lap/Shoulder Track Mounted Seat To A W/C Position To Lift Bus	\$780
THO83	All Buses	Seats	Exchange - 30 Inch Integrated Child Safety Restraint Seat in lieu of Standard 30 inch Seat (All Bodies) Suitable For 22lb To 85lb Children (Restraint Ready)	\$655
THO84	All Buses	Seats	Exchange - 30 Inch Integrated Child Safety Restraint Seat W/ Shoulder Belts - in lieu of Standard 30 inch Seat (All Bodies) Suitable For 22lb To 85lb Children (Shoulder Belts)	\$850
THO85	All Buses	Seats	Exchange - 39 Inch Integrated Child Safety Restraint Seat In lieu of Standard 39 Inch Seat (All Bodies) Suitable For 22lb To 85lb Children Suitable For 22lb To 85lb Children (Restraint Ready)	\$655
THO86	All Buses	Seats	Exchange - 39 Inch Integrated Child Safety Restraint Seat In lieu of Standard 39 Inch Seat (All Bodies) Suitable For 22lb To 85lb Children (With Shoulder Belts)	\$850
THO87	C	Seats	Add One Additional W/C Position - Add 1 FF630-4C To Lift Bus	\$1125
THO88	C	Seats	Delete One (1) Wheelchair Position & Add 2 Wall Mounted S3C Lap Shoulder Seats For Lift Bus (All	\$250

**OTHER OPTIONS**

Option	Bus Type	Option	Extended Description	Price
THO89	C	Noise Abatement	Acoustic Noise Abatement - Full body length - 34 Pass	\$375
THO90	C	Noise Abatement	Acoustic Noise Abatement - Full body length - 52 Pass	\$570
THO91	C	Noise Abatement	Acoustic Noise Abatement - Full body length- 66 -72 Pass	\$750
THO92	D	Noise Abatement	Acoustic Noise Abatement - Full body length - D Buses	\$950
THO93	ALL BUSES	Brakes	Adjustable Pedals - C2/D	\$1150
THO94	ALL BUSES	Brakes	Air Disc Brakes - All Buses	\$1625
THO95	C	Brakes	Bendix Intellipark - Parking Brake System	\$700

THO96	C	Floor	Flat Floor Upgrade On 34 With Lift	\$5400
THO97	C	Floor	One Piece Floor - 14 Or 34 Pass Bus (C2 Only)	\$1000
THO98	C	Floor	One Piece Floor - 20 Or 52 Pass Bus (C2 Only)	\$1200
THO99	C	Floor	One Piece Floor - 66 Or 72 Pass Bus (C2 Only)	\$1500
THO100	C	Headlights	Led Headlight - All Type C	\$940
THO101	D	Headlights	Led Headlights - All Type D	\$1000
THO102	C	Lights	Add 2 Lollipop Lights to Front Of Bus Hood	\$400
THO103	All Buses	Lights	Add 2 Additional Reverse Lights on Rear of Bus	\$200
THO104	All Buses	Lights	Reflective First Light Fully Illuminated Id / Destination Signs - Front & Rear - (Must Be Approved Pilot Only - Max Of 10 Total For Year & Limit Of 2 Per School District)	\$0
THO105	C	Tint	Tinted Windows - 34 Pass (Non-Lift)	\$400
THO106	C	Tint	Tinted Windows - 52 Pass (Non-Lift)	\$660
THO107	C	Tint	Tinted Windows - 66- 72 Pass (Non-Lift)	\$800
THO108	D	Tint	Tinted Windows - All Type D	\$1050
THO109	C	Tough Coat	Fleetshield Toughcoat Corrosion Protection Provides High Performance Coating On Front Bumper To Guard Against Corrosion, Moisture, Abrasions, Road Debris	\$400
THO110	All Buses	Trash Can	Trash Can (No Lid )	\$50
THO111	C	Underguard	Underguard - 34 Pass Corrosion Protection. High Performance Undercoating Applied to Underside Of Body	\$500
THO112	C	Underguard	Underguard - 52-72 Pass Corrosion Protection. High Performance Undercoating Applied to Underside Of Body	\$625
THO113	D	Underguard	Underguard - Type D Corrosion Protection. High Performance Undercoating Applied to Underside Of Body	\$750
THO114	C	Heater	Webasto Heater And 7 Day Timer for C2 Buses	\$1690
THO115	D	Heater	Webasto Heater & 7 Day Timer for Fc /Hdx Buses	\$2040
THO116	C-EV JOLEY	Charge Port	Remove Front Rs Charge Port and Add Rear RS Charge Port On EV Jouley Bus	\$2500
THO117	C	Fuel Tank	Fuel Tank Upgrade - 35 To 60 Gallon Tank - 34 Pass Shell Only	\$600
THO118	C	Fuel Tank	Fuel Tank Upgrade - 60 To 100 Gallon Tank - 52 To 72 Pass (C2)	\$800
THO119	All Buses	ZONAR	Add Zonar Box and Wiring To Bus	\$500
THO120	All Buses	Software	Cummins Insite Lite Software - Recurring Annual Fee	\$720
THO121	All Buses	Software	Cummins Insite Pro Software - Recurring Annual Fee	\$770
THO122	All Buses	Software	Cummins QuickServe Fleet Software - Recurring Annual Fee	\$750
THO123	All Buses	Software	Diagnostic Link 8 - Detroit - Recurring Annual Fee	\$530
THO124	All Buses	Software	Cat ET - Recurring Annual Fee	\$650
THO125	All Buses	Software	Allison Doc Software - Recurring Annual Fee	\$320
THO126	All Buses	Software	Meritor/Wabco Abs Software - Recurring Annual Fee	\$299
THO127	All Buses	Software	PSI Propane Software - Recurring Annual Fee	\$1,000



# SEATING CAPACITY: 12 + 2 WC + DRIVER

ITEM # TH1  
 CUMMINS  
 DIESEL  
 200 HP  
 2500 PTS  
 CAPACITY 12 + 2  
 WHEEL BASE - 159

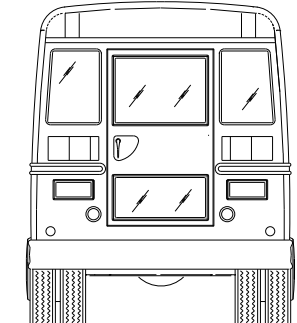
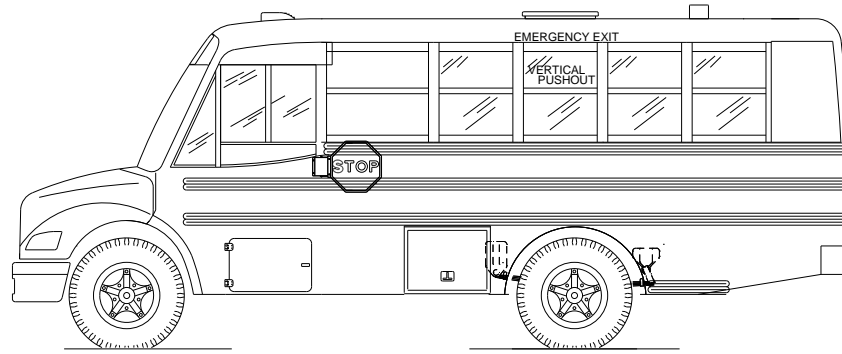

CAUTION! - LEFT SIDE BARRIER IS NOT IN STANDARD LOCATION, SEE SEATING PLAN.  
 CAUTION! - RIGHT SIDE BARRIER IS NOT IN STANDARD LOCATION, SEE SEATING PLAN.

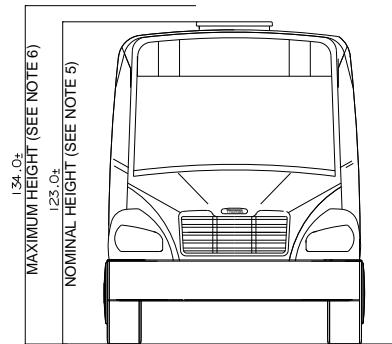
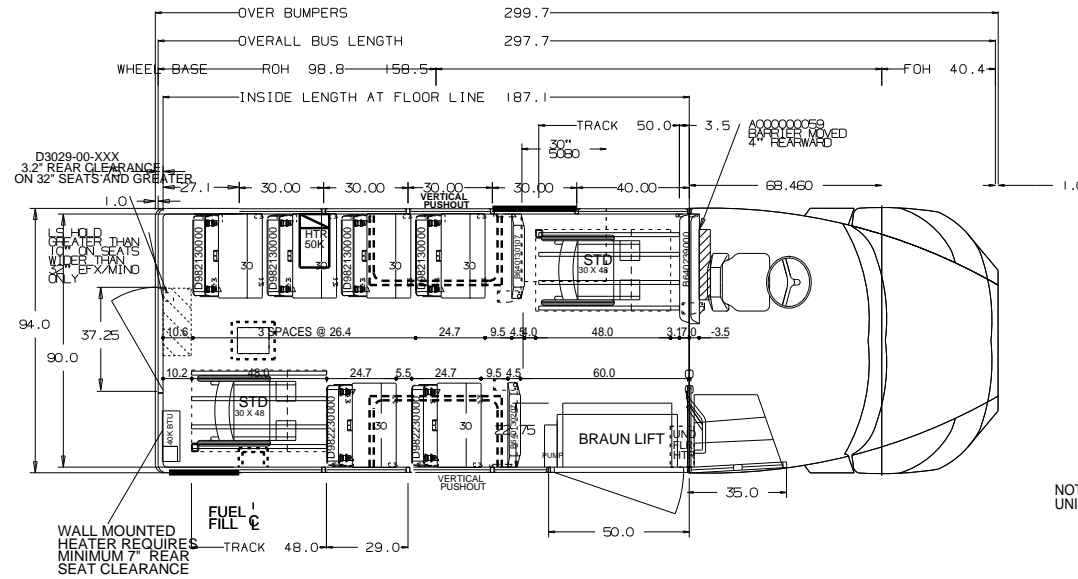

NOTES:  
 UNIT EQUIPPED WITH OVERHEAD TRACK REINFORCEMENT

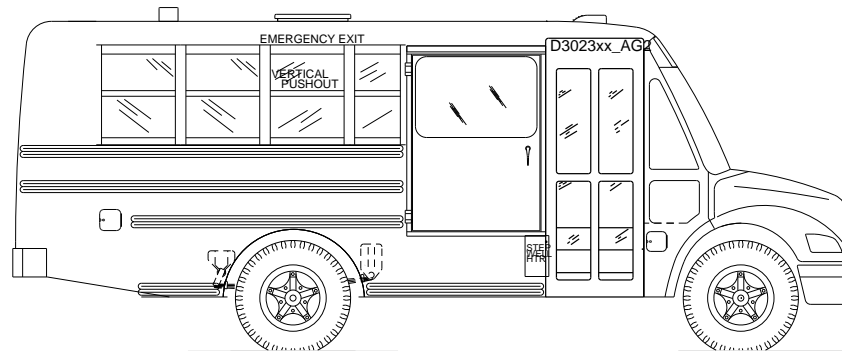

## ALL DIMENSIONS ARE FOR REFERENCE ONLY

### GENERAL NOTES

- SOME ITEMS, SUCH AS CV MIRRORS, ROOF LUGGAGE RACKS, AND OTHER ITEMS, ARE SHOWN IN ONE VIEW ONLY FOR CLARITY.
- THIS DRAWING IS A REPRESENTATION ONLY AND MAY NOT HAVE ALL ITEMS REQUIRED. PLEASE REFER TO ORDER!
- THE CLEARANCE BETWEEN BOTTOM OF BUS OR BOTTOM OF UNDERBODY COMPARTMENTS AND GROUND WILL VARY ACCORDING TO TIRE SIZE, BUS LOAD, AND SUSPENSION TYPE.
- THE MAXIMUM WIDTH AT BELT LINE OVER GUARD RAILS IS 96".
- THE NOMINAL BUS HEIGHT IS BASED ON A STANDARD BODY AND LARGEST SIZE TIRE.
- THE MAXIMUM BUS HEIGHT IS BASED ON BODY WITH OPTIONS SUCH AS A/C UNITS, STROBE LIGHT, CARGO SUSPENSION ETC.
- OVER BUMPER DIMENSION DOES NOT TAKE INTO ACCOUNT OPTIONS THAT MAY ADD TO THE TOTAL LENGTH OF THE BUS, SUCH AS MIRRORS, LIGHTS AND CROSSING ARMS.

THIS DRAWING AND ALL INFORMATION PROVIDED WITH IT ARE THE PROPERTY OF THOMAS BUILT BUSES, INC. ANY REPRODUCTION OR DISTRIBUTION OF THIS MATERIAL OR ANY PART WITHOUT WRITTEN PERMISSION OF THOMAS BUILT BUSES, INC. IS STRICTLY PROHIBITED. COPYRIGHT THOMAS BUILT BUSES, INC.

Model: Saf-T-Liner C2  
 Quote Number: 388018  
 Locality: KY

THOMAS BUILT BUSES, INC  
 HIGH POINT, NC

SIDE	ROW	SPACING	KNEE SPACE
LEFT		26.4	25.1

TITLE	PLAN AND ELEVATION BODY 161TS		
DRN	06-10-22	BY	T. Dean
SCALE	3/8"=12"	SIZE	DWG. NO.
		S	860237



# SEATING CAPACITY: 26 + 4 WC + DRIVER

ITEM # TH3  
 CUMMINS  
 DIESEL  
 220 HP  
 2500 PTS  
 CAPACITY 26 + 4  
 WHEEL BASE - 279

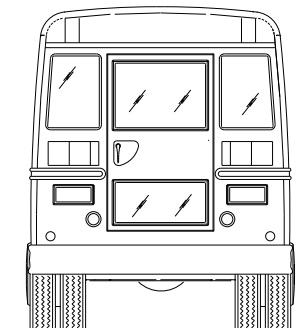
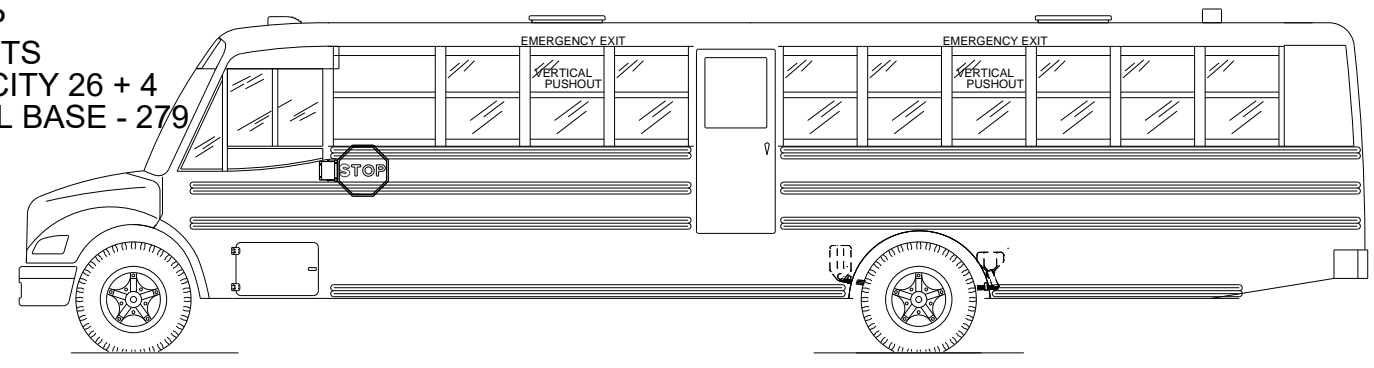

CAUTION - LEFT SIDE BARRIER IS NOT IN STANDARD LOCATION, SEE SEATING PLAN.  
 CAUTION! - RIGHT SIDE BARRIER IS NOT IN STANDARD LOCATION, SEE SEATING PLAN.

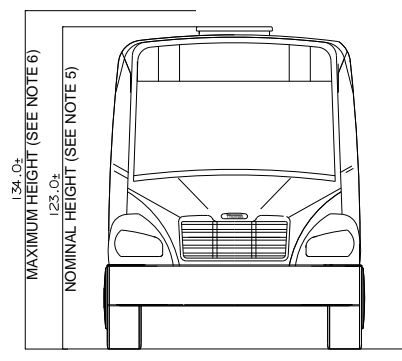
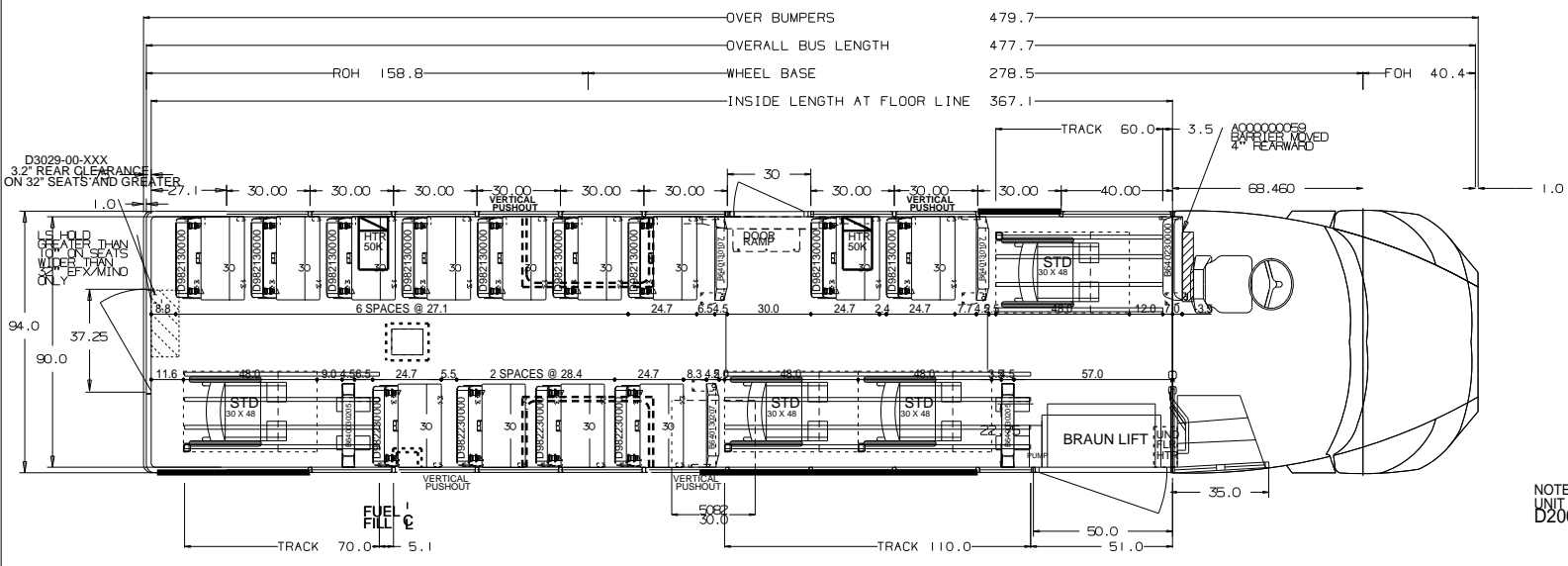

NOTES:  
 UNIT EQUIPPED WITH OVERHEAD TRACK REINFORCEMENT  
 D20000927 RAFTER CONFIG

### ALL DIMENSIONS ARE FOR REFERENCE ONLY

#### GENERAL NOTES

- SOME ITEMS, SUCH AS CV MIRRORS, ROOF LUGGAGE RACKS, AND OTHER ITEMS, ARE SHOWN IN ONE VIEW ONLY FOR CLARITY.
- THIS DRAWING IS A REPRESENTATION ONLY AND MAY NOT HAVE ALL ITEMS REQUIRED. PLEASE REFER TO ORDER!
- THE CLEARANCE BETWEEN BOTTOM OF BUS OR BOTTOM OF UNDERBODY COMPARTMENTS AND GROUND WILL VARY ACCORDING TO TIRE SIZE, BUS LOAD, AND SUSPENSION TYPE.
- THE MAXIMUM WIDTH AT BELT LINE OVER GUARD RAILS IS 96".
- THE NOMINAL BUS HEIGHT IS BASED ON A STANDARD BODY AND LARGEST TIRE SIZE.
- THE MAXIMUM BUS HEIGHT IS BASED ON BODY WITH OPTIONS SUCH AS A/C UNITS, STROBE LIGHT, CARGO SUSPENSION ETC.
- OVER BUMPER DIMENSION DOES NOT TAKE INTO ACCOUNT OPTIONS THAT MAY ADD TO THE TOTAL LENGTH OF THE BUS, SUCH AS MIRRORS, LIGHTS AND CROSSING ARMS.

Model: Saf-T-Liner C2  
 Quote Number: 388035  
 Locality: KY

THIS DRAWING AND ALL INFORMATION PROVIDED WITH IT ARE THE PROPERTY OF THOMAS BUILT BUSES, INC. ANY REPRODUCTION OR DISTRIBUTION OF THIS MATERIAL OR ANY PART WITHOUT WRITTEN PERMISSION OF THOMAS BUILT BUSES, INC. IS STRICTLY PROHIBITED. COPYRIGHT THOMAS BUILT BUSES, INC.

**THOMAS BUILT BUSES, INC**  
 HIGH POINT, NC

TITLE **PLAN AND ELEVATION BODY 341TS**

DRN: 06-10-22 BY: T. Dean SIZE 1/2" DWG. NO. **860239**

SIDE	ROW	SPACING	WHEEL WIDTH
LEFT		27.1	25.8
RIGHT		28.4	27.1

ITEM # TH4  
 CUMMINS  
 DIESEL  
 220 HP  
 3000 PTS  
 CAPACITY 26 + 4  
 WHEEL BASE - 279

# SEATING CAPACITY: 26 + 4 WC + DRIVER

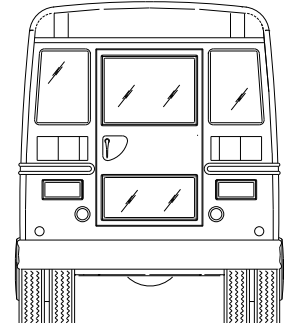
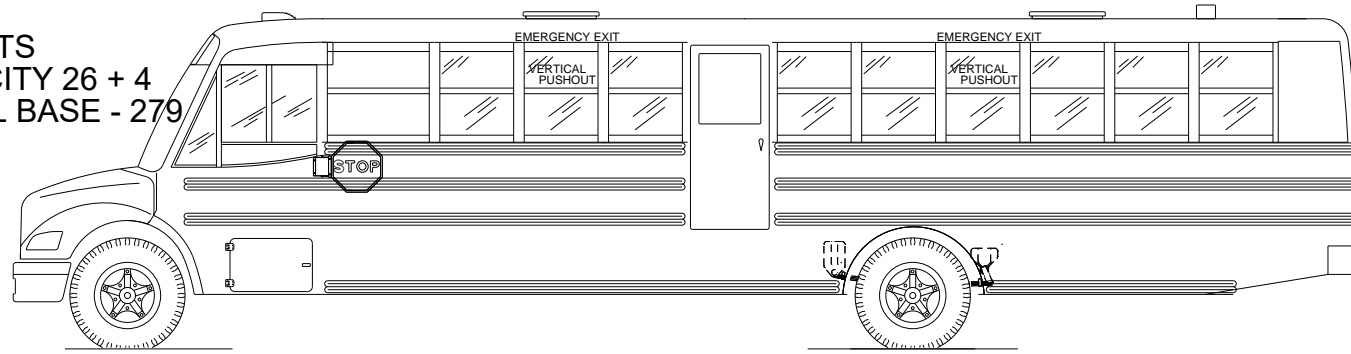

CAUTION! - LEFT SIDE BARRIER IS NOT IN STANDARD LOCATION, SEE SEATING PLAN.

CAUTION! - RIGHT SIDE BARRIER IS NOT IN STANDARD LOCATION, SEE SEATING PLAN.

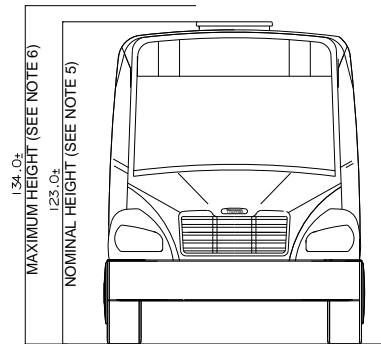
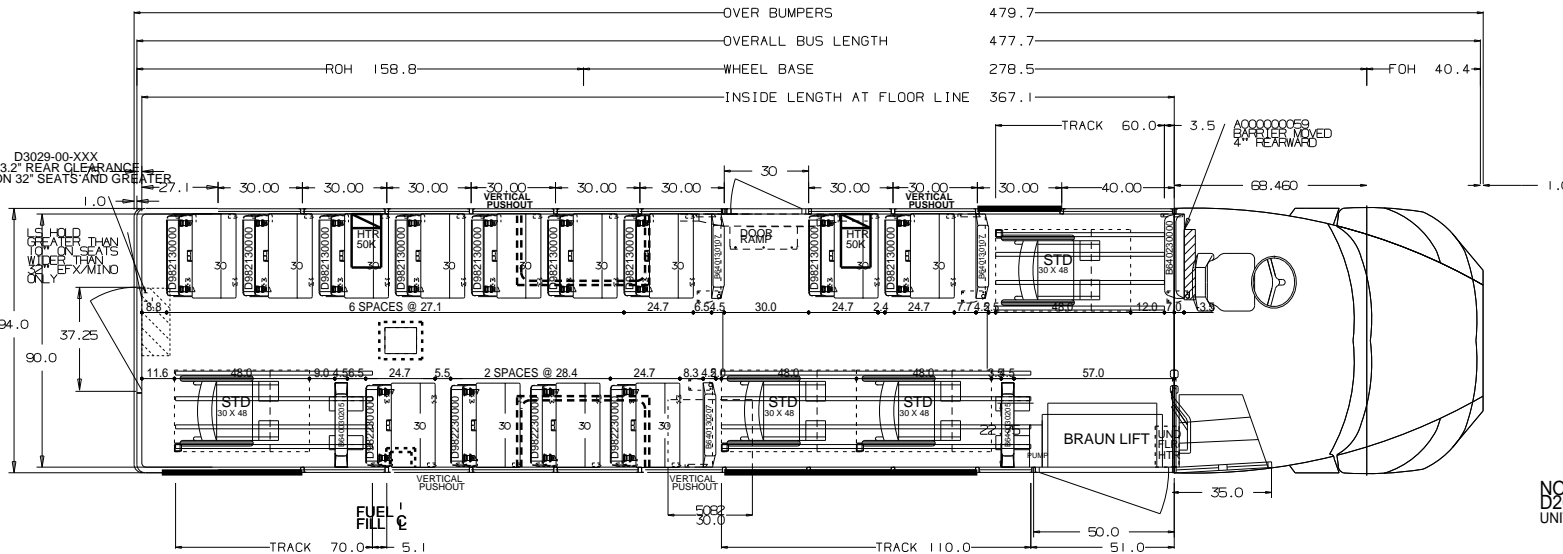

NOTES:  
 D200000927 RAFTER CONFIG  
 UNIT EQUIPPED WITH OVERHEAD TRACK REINFORCEMENT

## ALL DIMENSIONS ARE FOR REFERENCE ONLY

### GENERAL NOTES

- SOME ITEMS, SUCH AS CV MIRRORS, ROOF LUGGAGE RACKS, AND OTHER ITEMS, ARE SHOWN IN ONE VIEW ONLY FOR CLARITY.
- THIS DRAWING IS A REPRESENTATION ONLY AND MAY NOT HAVE ALL ITEMS REQUIRED. PLEASE REFER TO ORDER!
- THE CLEARANCE BETWEEN BOTTOM OF BUS OR BOTTOM OF UNDERBODY COMPARTMENTS AND GROUND WILL VARY ACCORDING TO TIRE SIZE, BUS LOAD, AND SUSPENSION TYPE.
- THE MAXIMUM WIDTH AT BELT LINE OVER GUARD RAILS IS 96".
- THE NOMINAL BUS HEIGHT IS BASED ON A STANDARD BODY AND LARGEST TIRE SIZE.
- THE MAXIMUM BUS HEIGHT IS BASED ON BODY WITH OPTIONS SUCH AS A/C UNITS, STROBE LIGHT, CARGO SUSPENSION ETC.
- OVER BUMPER DIMENSION DOES NOT TAKE INTO ACCOUNT OPTIONS THAT MAY ADD TO THE TOTAL LENGTH OF THE BUS, SUCH AS MIRRORS, LIGHTS AND CROSSING ARMS.

THIS DRAWING AND ALL INFORMATION PROVIDED WITH IT ARE THE PROPERTY OF THOMAS BUILT BUSES, INC. ANY REPRODUCTION OR DISTRIBUTION OF THIS MATERIAL OR ANY PART WITHOUT WRITTEN PERMISSION OF THOMAS BUILT BUSES, INC. IS STRICTLY PROHIBITED. COPYRIGHT THOMAS BUILT BUSES, INC.

Model: Saf-T-Liner C2  
 Quote Number: 388036  
 Locality: KY

SIDE	ROW	SPACING	WHEEL BASE
LEFT		27.1	25.8
RIGHT		28.4	27.1

TITLE PLAN AND ELEVATION BODY 341TS  
 DRN:06-10-22 BY:T. Dean SIZE DWG. NO.  
 SCALE 3/8"=12" S 860234

THOMAS BUILT BUSES, INC  
 HIGH POINT, NC

# SEATING CAPACITY: 26 + 4 WC + DRIVER

ITEM # TH5  
161 HP PROTERRA  
CAPACITY 26 + 4  
WHEEL BASE - 279

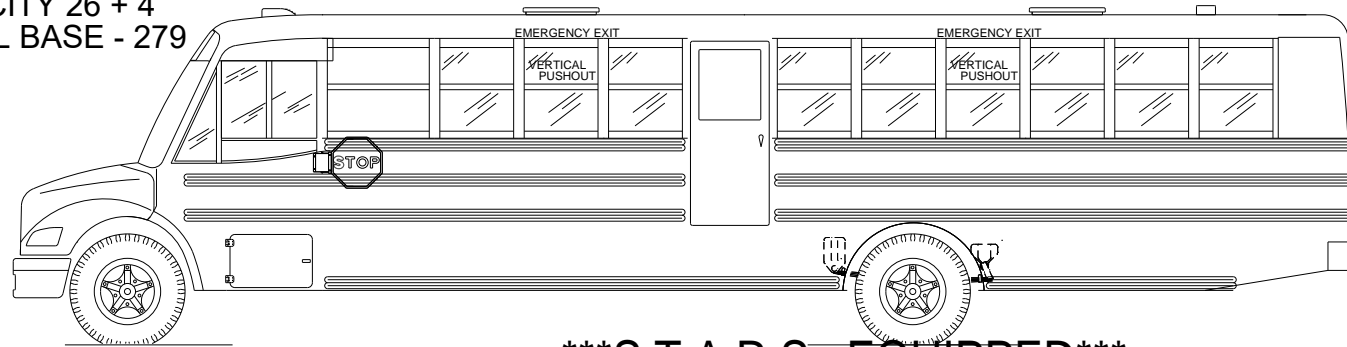

\*\*\*STARS EQUIPPED\*\*\*

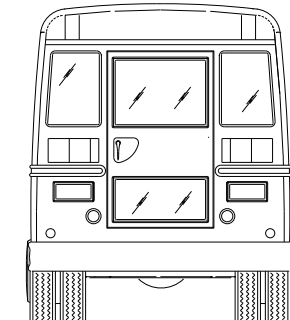

CAUTION! - LEFT SIDE BARRIER IS NOT IN STANDARD LOCATION, SEE SEATING PLAN.

CAUTION! - RIGHT SIDE BARRIER IS NOT IN STANDARD LOCATION, SEE SEATING PLAN.

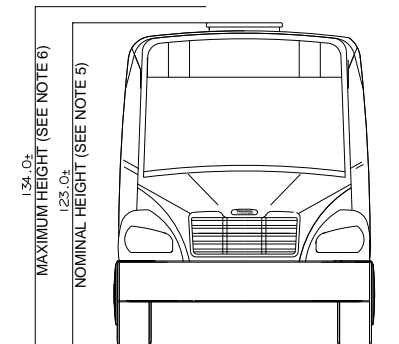
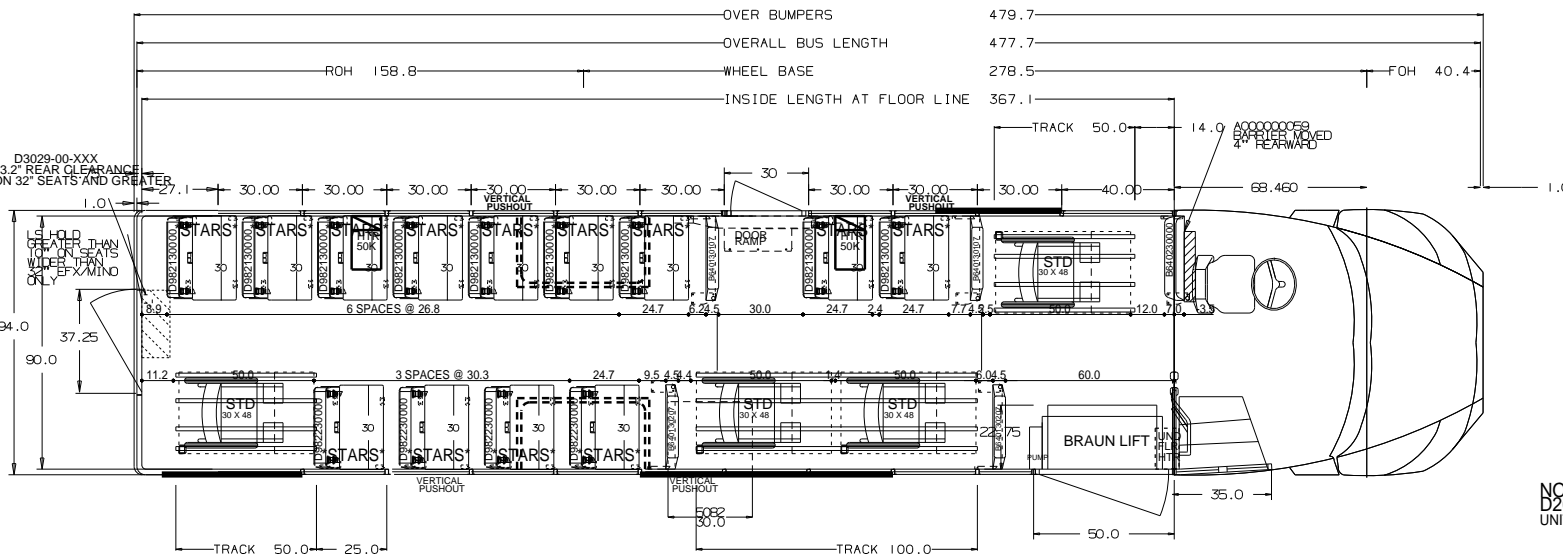

NOTES:  
D200000927 RAFTER CONFIG  
UNIT EQUIPPED WITH OVERHEAD TRACK REINFORCEMENT

ALL DIMENSIONS ARE FOR REFERENCE ONLY

GENERAL NOTES

- SOME ITEMS, SUCH AS CV MIRRORS, ROOF LUGGAGE RACKS, AND OTHER ITEMS, ARE SHOWN IN ONE VIEW ONLY FOR CLARITY.
- THIS DRAWING IS A REPRESENTATION ONLY AND MAY NOT HAVE ALL ITEMS REQUIRED. PLEASE REFER TO ORDER!
- THE CLEARANCE BETWEEN BOTTOM OF BUS OR BOTTOM OF UNDERBODY COMPARTMENTS AND GROUND WILL VARY ACCORDING TO TIRE SIZE, BUS LOAD, AND SUSPENSION TYPE.
- THE MAXIMUM WIDTH AT BELT LINE OVER GUARD RAILS IS 96".
- THE NOMINAL BUS HEIGHT IS BASED ON A STANDARD BODY AND LARGEST TIRE SIZE.
- THE MAXIMUM BUS HEIGHT IS BASED ON BODY WITH OPTIONS SUCH AS A/C UNITS, STROBE LIGHT, CARGO SUSPENSION ETC.
- OVER BUMPER DIMENSION DOES NOT TAKE INTO ACCOUNT OPTIONS THAT MAY ADD TO THE TOTAL LENGTH OF THE BUS, SUCH AS MIRRORS, LIGHTS AND CROSSING ARMS.

THIS DRAWING AND ALL INFORMATION PROVIDED WITH IT ARE THE PROPERTY OF THOMAS BUILT BUSES, INC. ANY REPRODUCTION OR DISTRIBUTION OF THIS MATERIAL OR ANY PART WITHOUT WRITTEN PERMISSION OF THOMAS BUILT BUSES, INC. IS STRICTLY PROHIBITED. COPYRIGHT THOMAS BUILT BUSES, INC.

Model: Saf-T-Liner C2  
Quote Number: 388433  
Locality: KY

SIDE	ROW	SPACING	WHEEL SPACING
LEFT		26.8	25.5
RIGHT		30.3	29.0

TITLE: PLAN AND ELEVATION BODY 341TS  
DRN: 06-03-22 BY: T. Dean SIZE: DWG. NO. S 860036  
SCALE: 3/8"=12" Program Version: 22.4.4

# SEATING CAPACITY: 34 + DRIVER

ITEM # TH6  
 CUMMINS  
 DIESEL  
 200 HP  
 2500 PTS  
 CAPACITY 34  
 WHEEL BASE - 159

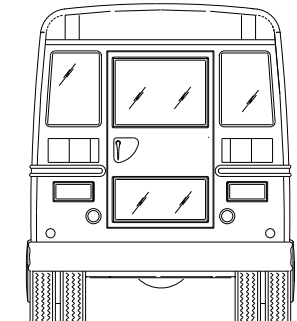
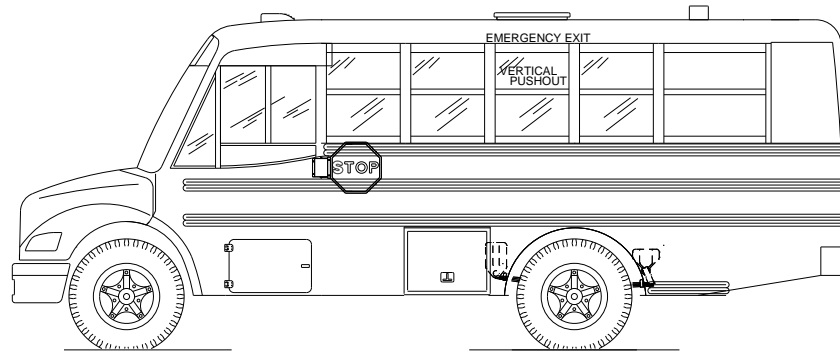

CAUTION - LEFT SIDE BARRIER IS NOT IN STANDARD LOCATION, SEE SEATING PLAN.

CAUTION! - RIGHT SIDE BARRIER IS NOT IN STANDARD LOCATION, SEE SEATING PLAN.

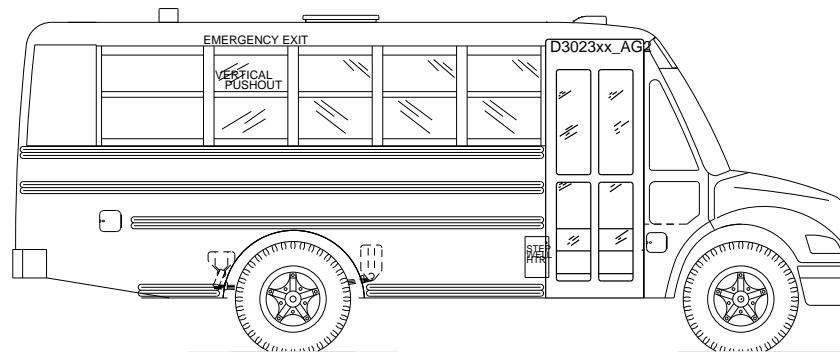
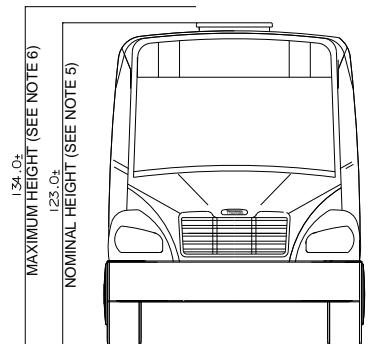
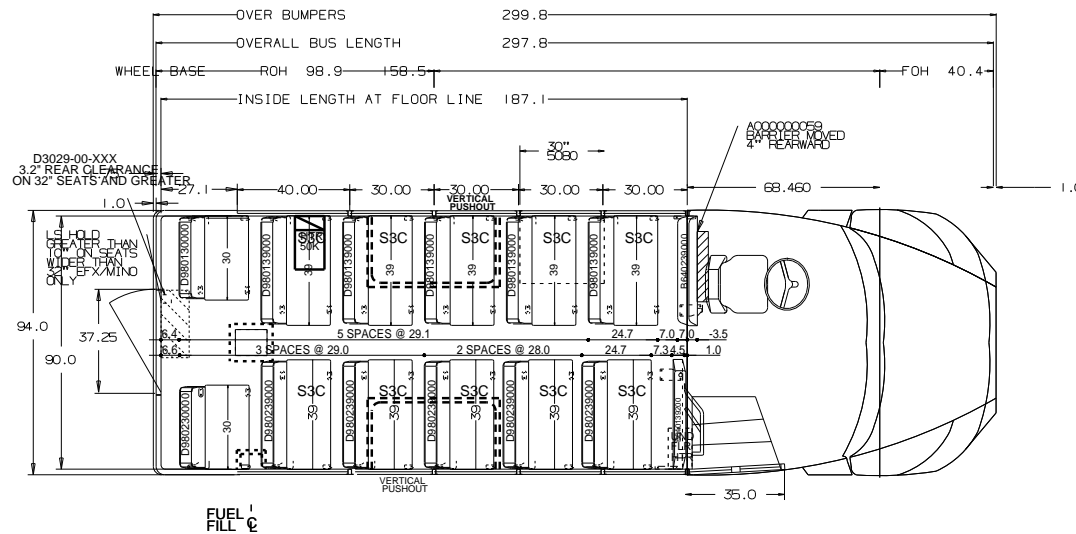

**ALL DIMENSIONS ARE FOR REFERENCE ONLY**

**GENERAL NOTES**

- SOME ITEMS, SUCH AS CV MIRRORS, ROOF LUGGAGE RACKS, AND OTHER ITEMS, ARE SHOWN IN ONE VIEW ONLY FOR CLARITY.
- THIS DRAWING IS A REPRESENTATION ONLY AND MAY NOT HAVE ALL ITEMS REQUIRED. PLEASE REFER TO ORDER!
- THE CLEARANCE BETWEEN BOTTOM OF BUS OR BOTTOM OF UNDERBODY COMPARTMENTS AND GROUND WILL VARY ACCORDING TO TIRE SIZE, BUS LOAD, AND SUSPENSION TYPE.
- THE MAXIMUM WIDTH AT BELT LINE OVER GUARD RAILS IS 96\"/>

Model: Saf-T-Liner C2  
 Quote Number: 388023  
 Locality: KY

THIS DRAWING AND ALL INFORMATION PROVIDED WITH IT ARE THE PROPERTY OF THOMAS BUILT BUSES, INC. ANY REPRODUCTION OR DISTRIBUTION OF THIS MATERIAL OR ANY PART WITHOUT WRITTEN PERMISSION OF THOMAS BUILT BUSES, INC. IS STRICTLY PROHIBITED. COPYRIGHT THOMAS BUILT BUSES, INC.

SIDE	ROW	SPACING	WHEEL BASE
LEFT		29.1	27.8
RIGHT		28.0	26.7
RIGHT		29.0	27.7

TITLE		PLAN AND ELEVATION BODY 161TS	
DRN:06-10-22	BY:T. Dean	SIZE	DWG. NO.
SCALE	3/8"=12"	S	860240

ITEM # TH7  
 CUMMINS  
 DIESEL  
 200 HP  
 2500 PTS  
 CAPACITY 52  
 WHEEL BASE - 219

# SEATING CAPACITY: 52 + DRIVER

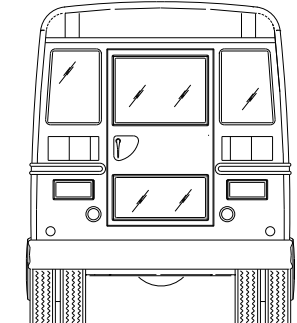
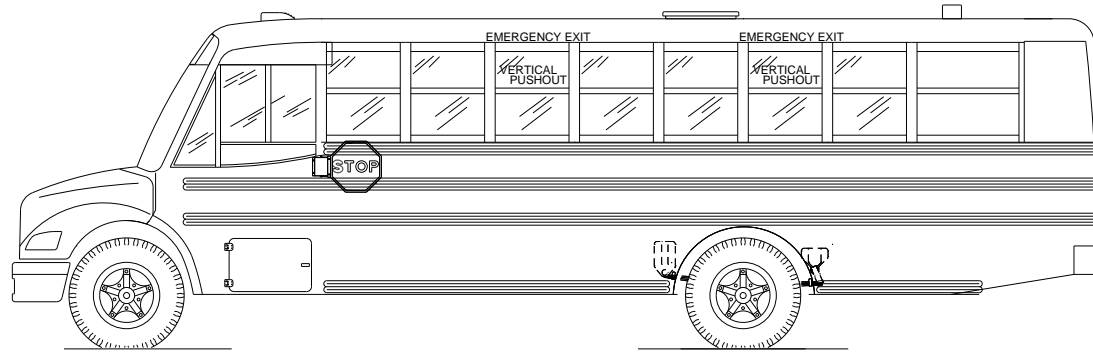

CAUTION - LEFT SIDE BARRIER IS NOT IN STANDARD LOCATION, SEE SEATING PLAN.

CAUTION! - RIGHT SIDE BARRIER IS NOT IN STANDARD LOCATION, SEE SEATING PLAN.

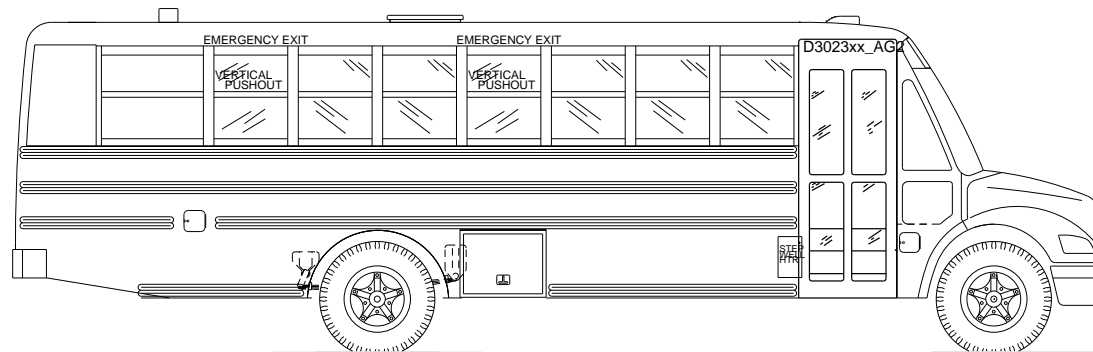
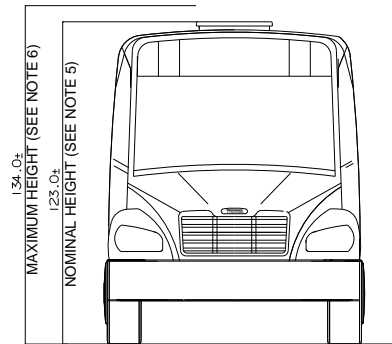
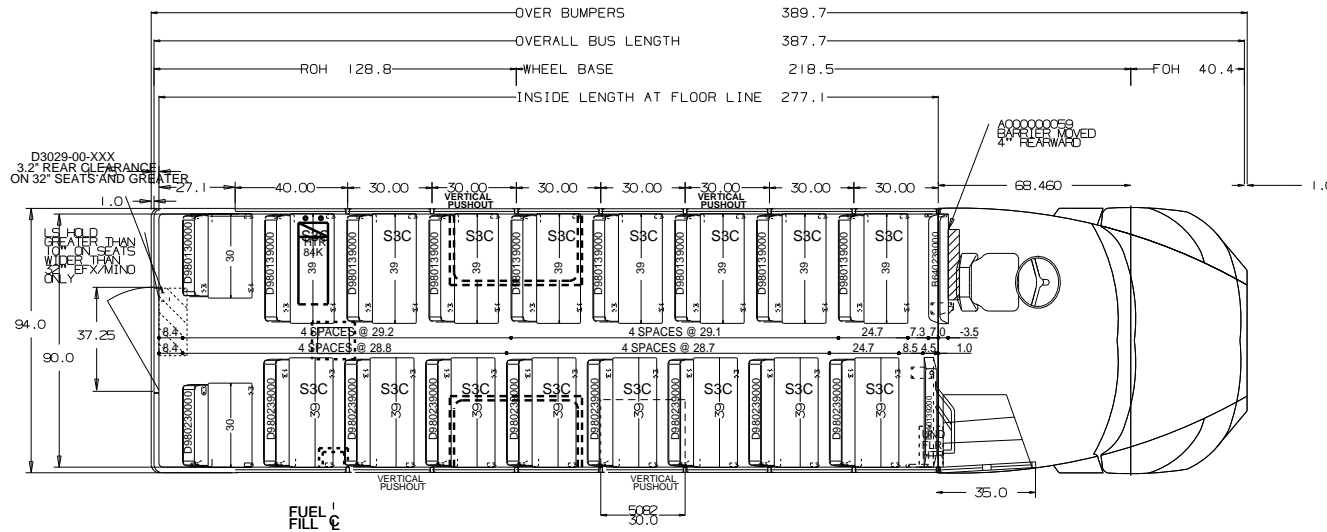

ALL DIMENSIONS ARE FOR REFERENCE ONLY

- GENERAL NOTES
- SOME ITEMS, SUCH AS CV MIRRORS, ROOF LUGGAGE RACKS, AND OTHER ITEMS, ARE SHOWN IN ONE VIEW ONLY FOR CLARITY.
  - THIS DRAWING IS A REPRESENTATION ONLY AND MAY NOT HAVE ALL ITEMS REQUIRED. PLEASE REFER TO ORDER!
  - THE CLEARANCE BETWEEN BOTTOM OF BUS OR BOTTOM OF UNDERBODY COMPARTMENTS AND GROUND WILL VARY ACCORDING TO TIRE SIZE, BUS LOAD, AND SUSPENSION TYPE.
  - THE MAXIMUM WIDTH AT BELT LINE OVER GUARD RAILS IS 96".
  - THE NOMINAL BUS HEIGHT IS BASED ON A STANDARD BODY AND LARGEST SIZE TIRE.
  - THE MAXIMUM BUS HEIGHT IS BASED ON BODY WITH OPTIONS SUCH AS A/C UNITS, STROBE LIGHT, LARGEST SUSPENSION ETC.
  - OVER BUMPER DIMENSION DOES NOT TAKE INTO ACCOUNT OPTIONS THAT MAY ADD TO THE TOTAL LENGTH OF THE BUS, SUCH AS MIRRORS, LIGHTS AND CROSSING ARMS.

Model: Saf-T-Liner C2  
 Quote Number: 388027  
 Locality: KY

THIS DRAWING AND ALL INFORMATION PROVIDED WITH IT ARE THE PROPERTY OF THOMAS BUILT BUSES, INC. ANY REPRODUCTION OR DISTRIBUTION OF THIS MATERIAL OR ANY PART WITHOUT WRITTEN PERMISSION OF THOMAS BUILT BUSES, INC. IS STRICTLY PROHIBITED. COPYRIGHT THOMAS BUILT BUSES, INC.

SIDE	ROW	SPACING	WHEEL RISE
LEFT		29.1	27.8
LEFT		29.2	27.9
RIGHT		28.7	27.4
RIGHT		28.8	27.5

TITLE: PLAN AND ELEVATION BODY 251TS  
 DRN:06-10-22 BY:T. Dean  
 SCALE 3/8"=12" SIZE DWG. NO. 860235

THOMAS BUILT BUSES, INC  
 HIGH POINT, NC

ITEM # TH8  
 CUMMINS  
 DIESEL  
 220 HP  
 2500 PTS  
 CAPACITY 66  
 WHEEL BASE - 279

# SEATING CAPACITY: 66 + DRIVER

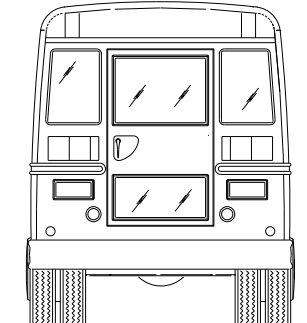
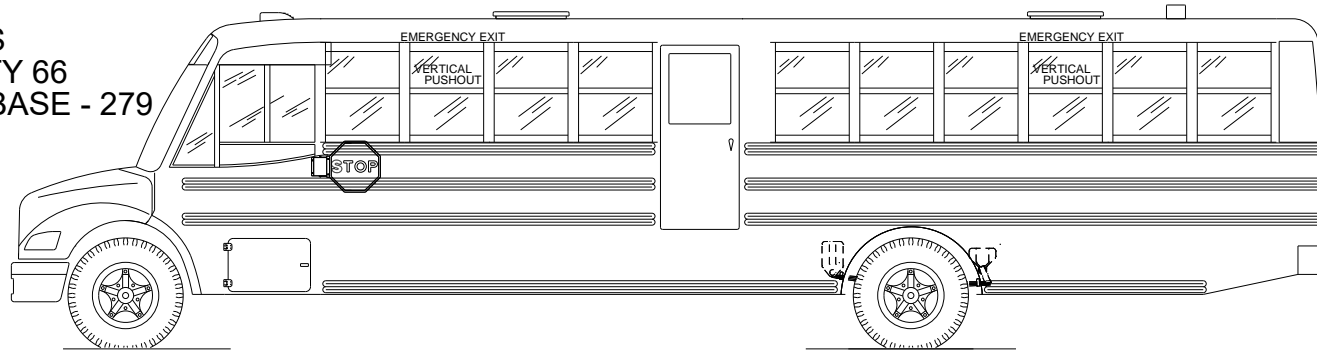

CAUTION! - LEFT SIDE BARRIER IS NOT IN STANDARD LOCATION, SEE SEATING PLAN.  
 CAUTION! - RIGHT SIDE BARRIER IS NOT IN STANDARD LOCATION, SEE SEATING PLAN.

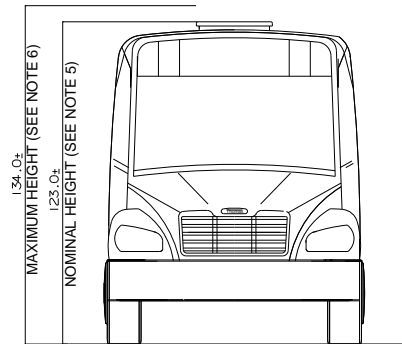
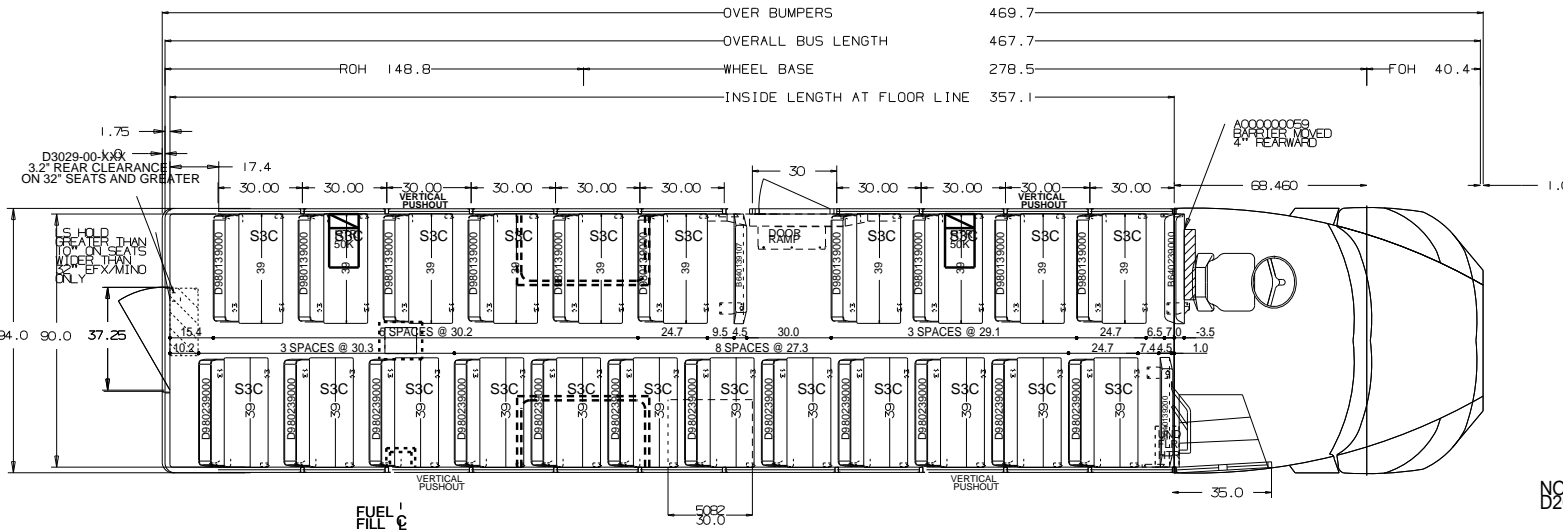

NOTES:  
 D20000805 - LS DOOR LOC. NO 5 (10\"/>

**ALL DIMENSIONS ARE FOR REFERENCE ONLY**

**GENERAL NOTES**

- SOME ITEMS, SUCH AS CV MIRRORS, ROOF LUGGAGE RACKS, AND OTHER ITEMS, ARE SHOWN IN ONE VIEW ONLY FOR CLARITY.
- THIS DRAWING IS A REPRESENTATION ONLY AND MAY NOT HAVE ALL ITEMS REQUIRED. PLEASE REFER TO ORDER!
- THE CLEARANCE BETWEEN BOTTOM OF BUS OR BOTTOM OF UNDERBODY COMPARTMENTS AND GROUND WILL VARY ACCORDING TO TIRE SIZE, BUS LOAD, AND SUSPENSION TYPE.
- THE MAXIMUM WIDTH AT BELT LINE OVER GUARD RAILS IS 96\"/>
- THE NOMINAL BUS HEIGHT IS BASED ON A STANDARD BODY AND LARGEST TIRE SIZE.
- THE MAXIMUM BUS HEIGHT IS BASED ON BODY WITH OPTIONS SUCH AS A/C UNITS, STROBE LIGHT, CARRIER SUSPENSION ETC.
- OVER BUMPER DIMENSION DOES NOT TAKE INTO ACCOUNT OPTIONS THAT MAY ADD TO THE TOTAL LENGTH OF THE BUS, SUCH AS MIRRORS, LIGHTS AND CROSSING ARMS.

THIS DRAWING AND ALL INFORMATION PROVIDED WITH IT ARE THE PROPERTY OF THOMAS BUILT BUSES, INC. ANY REPRODUCTION OR DISTRIBUTION OF THIS MATERIAL OR ANY PART WITHOUT WRITTEN PERMISSION OF THOMAS BUILT BUSES, INC. IS STRICTLY PROHIBITED. COPYRIGHT THOMAS BUILT BUSES, INC.

Model: Saf-T-Liner C2  
 Quote Number: 388030  
 Locality: KY

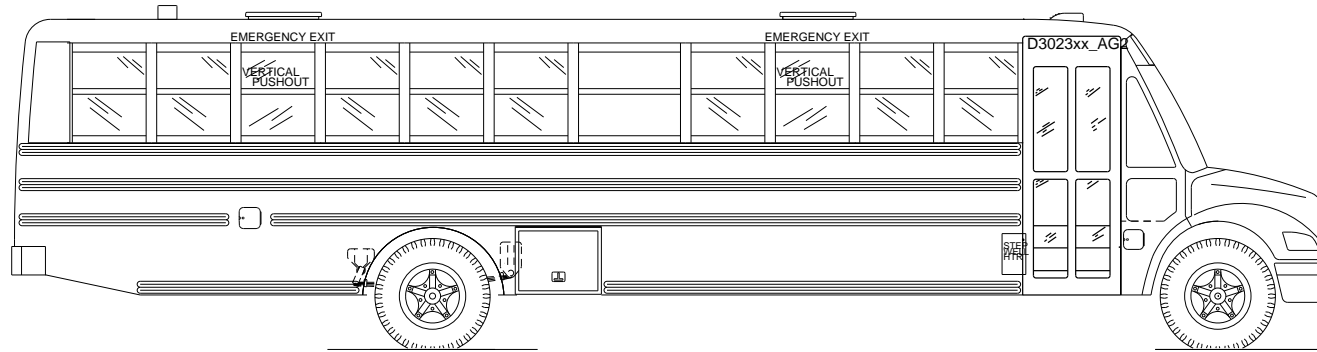

SIDE	ROW	SPACING	WHEEL BASE
LEFT		29.1	27.8
LEFT		30.2	28.9
RIGHT		27.3	26.0
RIGHT		30.3	29.0

  

TITLE		PLAN AND ELEVATION BODY 340TS	
DRN:06-10-22	BY:T. Dean	SIZE	DWG. NO.
SCALE	3/8"=12"	S	860227



ITEM # TH9  
 CUMMINS  
 DIESEL  
 220 HP  
 3000 PTS  
 CAPACITY 66  
 WHEEL BASE - 279

# SEATING CAPACITY: 66 + DRIVER

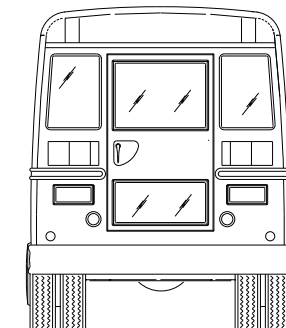
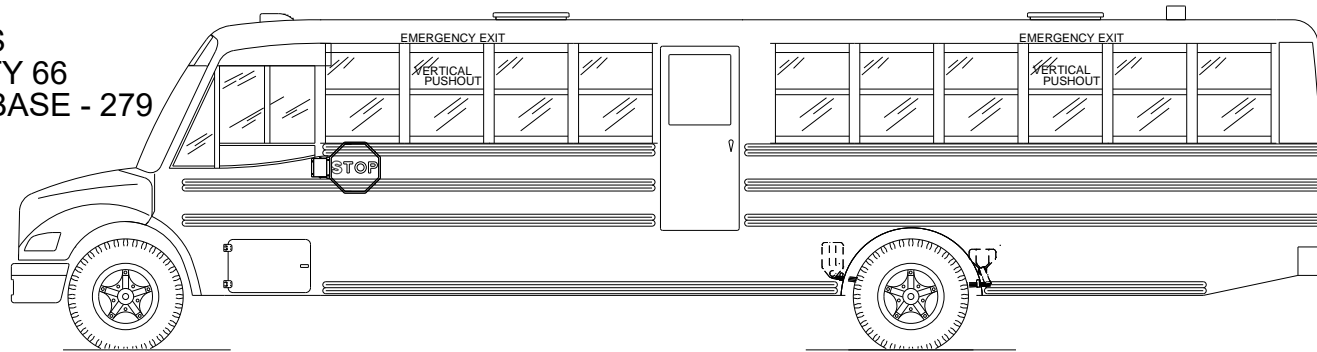

CAUTION! - LEFT SIDE BARRIER IS NOT IN STANDARD LOCATION, SEE SEATING PLAN.

CAUTION! - RIGHT SIDE BARRIER IS NOT IN STANDARD LOCATION, SEE SEATING PLAN.

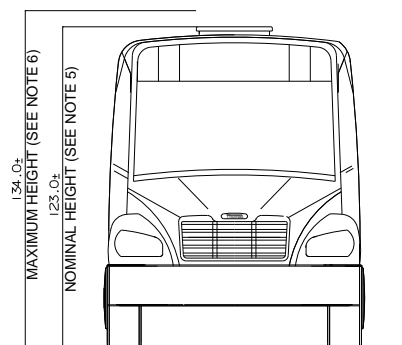
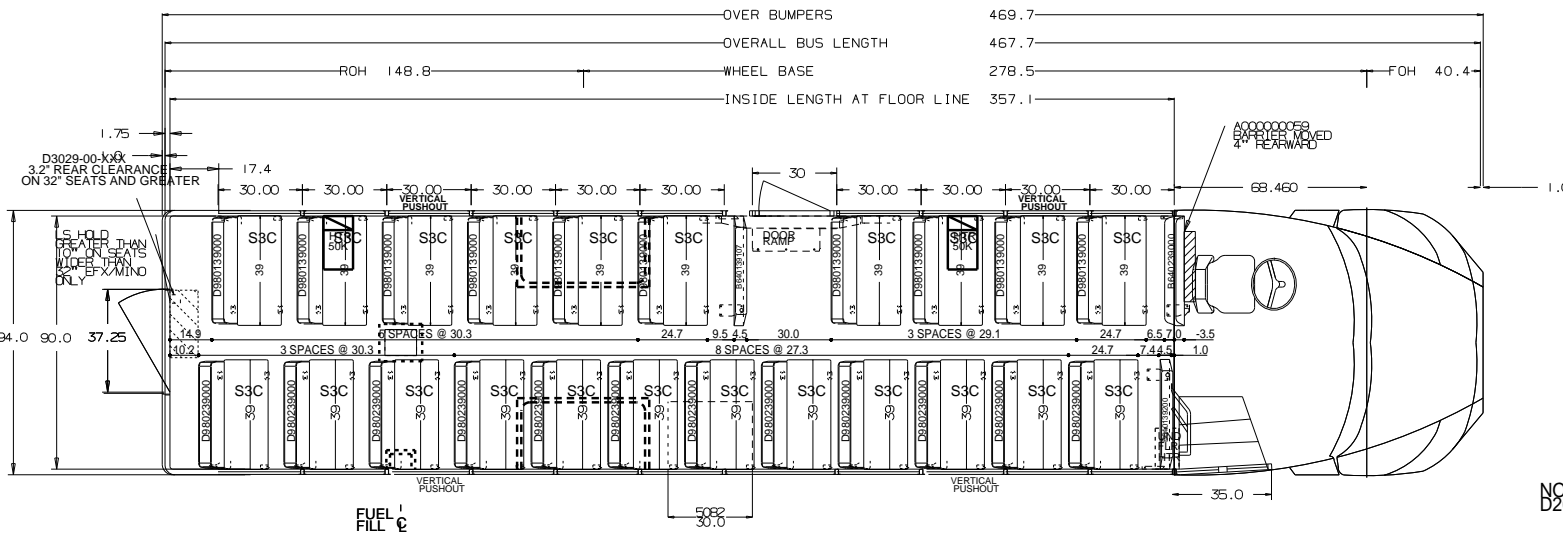

NOTES:  
 D200000805 - LS DOOR LOC. NO 5 (10" REAR)

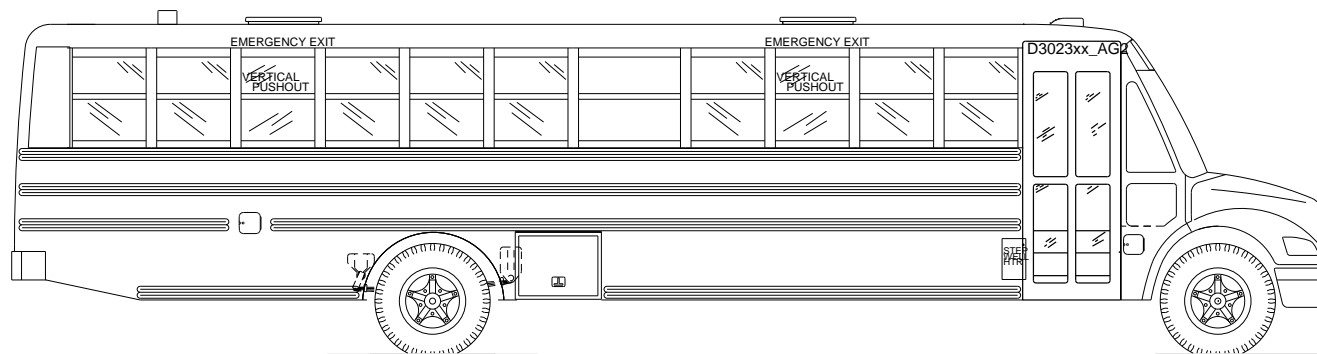

**ALL DIMENSIONS ARE FOR REFERENCE ONLY**

**GENERAL NOTES**

- SOME ITEMS, SUCH AS CV MIRRORS, ROOF LUGGAGE RACKS, AND OTHER ITEMS, ARE SHOWN IN ONE VIEW ONLY FOR CLARITY.
- THIS DRAWING IS A REPRESENTATION ONLY AND MAY NOT HAVE ALL ITEMS REQUIRED. PLEASE REFER TO ORDER!
- THE CLEARANCE BETWEEN BOTTOM OF BUS OR BOTTOM OF UNDERBODY COMPARTMENTS AND GROUND WILL VARY ACCORDING TO TIRE SIZE, BUS LOAD, AND SUSPENSION TYPE.
- THE MAXIMUM WIDTH AT BELT LINE OVER GUARD RAILS IS 96".
- THE NOMINAL BUS HEIGHT IS BASED ON A STANDARD BODY AND LARGEST TIRE SIZE.
- THE MAXIMUM BUS HEIGHT IS BASED ON BODY WITH OPTIONS SUCH AS A/C UNITS, STROBE LIGHT, CARRIER SUSPENSION ETC.
- OVER BUMPER DIMENSION DOES NOT TAKE INTO ACCOUNT OPTIONS THAT MAY ADD TO THE TOTAL LENGTH OF THE BUS, SUCH AS MIRRORS, LIGHTS AND CROSSING ARMS.

THIS DRAWING AND ALL INFORMATION PROVIDED WITH IT ARE THE PROPERTY OF THOMAS BUILT BUSES, INC. ANY REPRODUCTION OR DISTRIBUTION OF THIS MATERIAL OR ANY PART WITHOUT WRITTEN PERMISSION OF THOMAS BUILT BUSES, INC. IS STRICTLY PROHIBITED. COPYRIGHT THOMAS BUILT BUSES, INC.

Model: Saf-T-Liner C2  
 Quote Number: 388031  
 Locality: KY

SIDE	ROW	SPACING	WHEEL RADIUS
LEFT		29.1	27.8
LEFT		30.3	29.0
RIGHT		27.3	26.0
RIGHT		30.3	29.0

TITLE		PLAN AND ELEVATION BODY 340TS	
DRN:06-10-22	BY:T. Dean	SIZE	DWG. NO.
SCALE 3/8"=12"		S	860236

ITEM # TH10  
 CUMMINS  
 DIESEL  
 220 HP  
 2500 PTS  
 CAPACITY 72  
 WHEEL BASE - 279

# SEATING CAPACITY: 72 + DRIVER

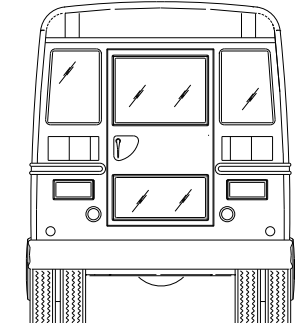
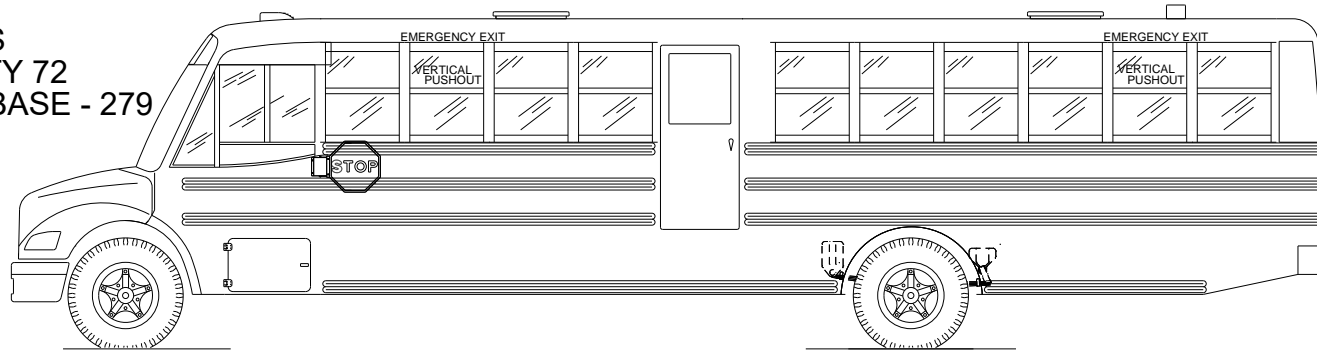

CAUTION - LEFT SIDE BARRIER IS NOT IN STANDARD LOCATION, SEE SEATING PLAN.

CAUTION! - RIGHT SIDE BARRIER IS NOT IN STANDARD LOCATION, SEE SEATING PLAN.

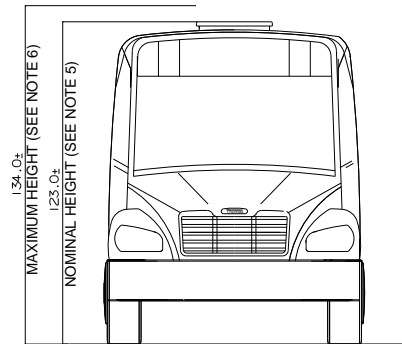
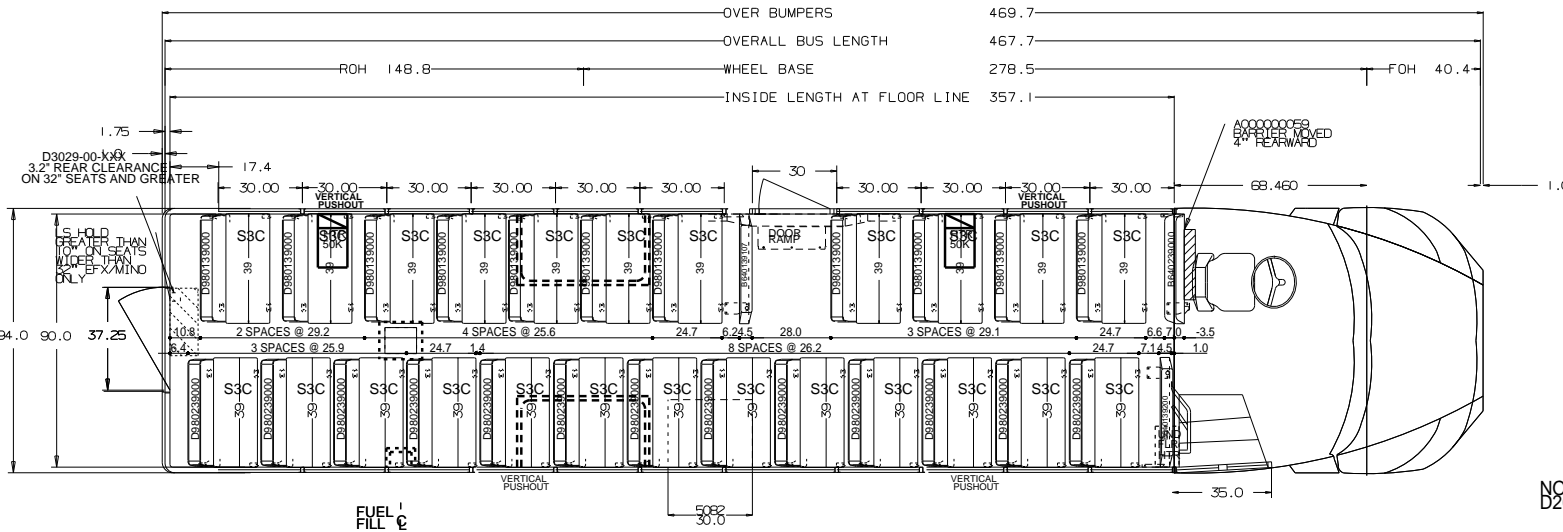

NOTES:  
 D200000805 - LS DOOR LOC. NO 5 (10" REAR)

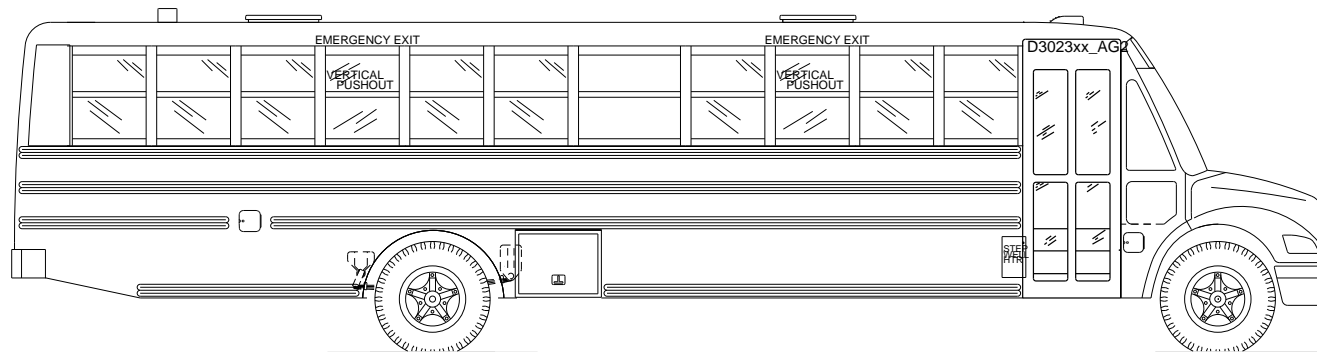

## ALL DIMENSIONS ARE FOR REFERENCE ONLY

### GENERAL NOTES

- SOME ITEMS, SUCH AS CV MIRRORS, ROOF LUGGAGE RACKS, AND OTHER ITEMS, ARE SHOWN IN ONE VIEW ONLY FOR CLARITY.
- THIS DRAWING IS A REPRESENTATION ONLY AND MAY NOT HAVE ALL ITEMS REQUIRED. PLEASE REFER TO ORDER!
- THE CLEARANCE BETWEEN BOTTOM OF BUS OR BOTTOM OF UNDERBODY COMPARTMENTS AND GROUND WILL VARY ACCORDING TO TIRE SIZE, BUS LOAD, AND SUSPENSION TYPE.
- THE MAXIMUM WIDTH AT BELT LINE OVER GUARD RAILS IS 96".
- THE NOMINAL BUS HEIGHT IS BASED ON A STANDARD BODY AND LARGEST TIRE SIZE.
- THE MAXIMUM BUS HEIGHT IS BASED ON BODY WITH OPTIONS SUCH AS A/C UNITS, STROBE LIGHT, CARGO SUSPENSION ETC.
- OVER BUMPER DIMENSION DOES NOT TAKE INTO ACCOUNT OPTIONS THAT MAY ADD TO THE TOTAL LENGTH OF THE BUS, SUCH AS MIRRORS, LIGHTS AND CROSSING ARMS.

Model: Saf-T-Liner C2  
 Quote Number: 388033  
 Locality: KY

THIS DRAWING AND ALL INFORMATION PROVIDED WITH IT ARE THE PROPERTY OF THOMAS BUILT BUSES, INC. ANY REPRODUCTION OR DISTRIBUTION OF THIS MATERIAL OR ANY PART WITHOUT WRITTEN PERMISSION OF THOMAS BUILT BUSES, INC. IS STRICTLY PROHIBITED. COPYRIGHT THOMAS BUILT BUSES, INC.

SIDE	ROW	SPACING	SEAT WIDTH	SEAT DEPTH
LEFT		29.1	27.8	
LEFT		25.6	24.3	
LEFT		29.2	27.9	
RIGHT		26.2	24.9	
RIGHT		25.9	24.6	

TITLE	PLAN AND ELEVATION BODY 340TS		
DRN	06-10-22	BY: T. Dean	SIZE DWG. NO.
SCALE	3/8"=12"		860230





# SEATING CAPACITY: 72 + DRIVER

ITEM # TH15  
161 HP PROTERRA  
CAPACITY 72  
WHEEL BASE - 279  
REAR AXLE OH 149

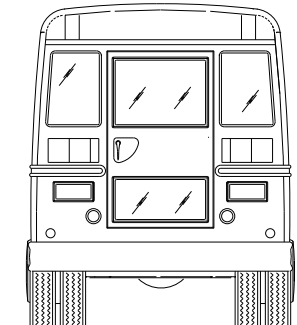
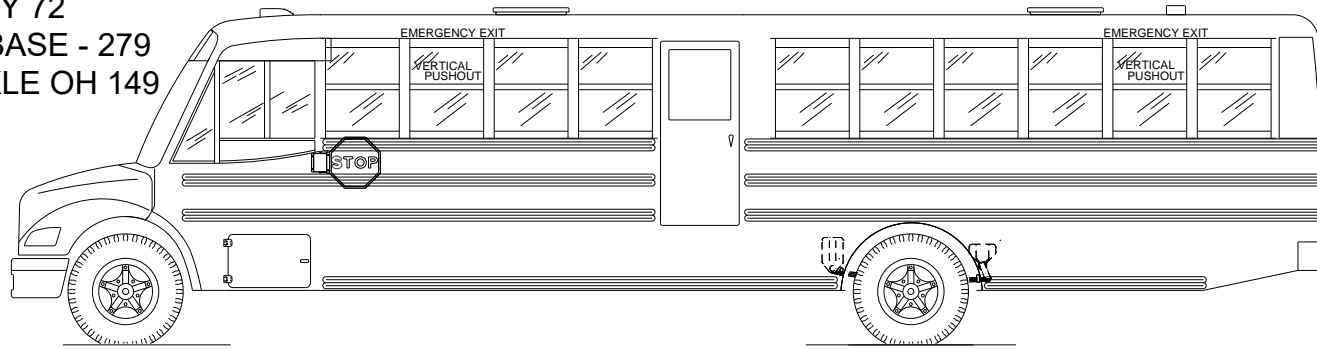

CAUTION! - LEFT SIDE BARRIER IS NOT IN STANDARD LOCATION, SEE SEATING PLAN.  
CAUTION! - RIGHT SIDE BARRIER IS NOT IN STANDARD LOCATION, SEE SEATING PLAN.

\*\*\*EV UNIT SEE STARS LOCATIONS\*\*\*

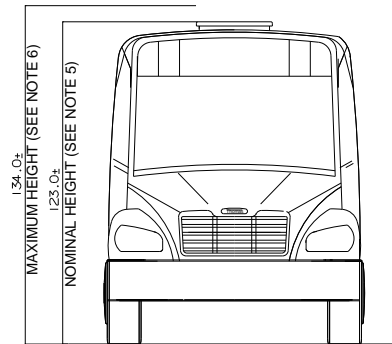
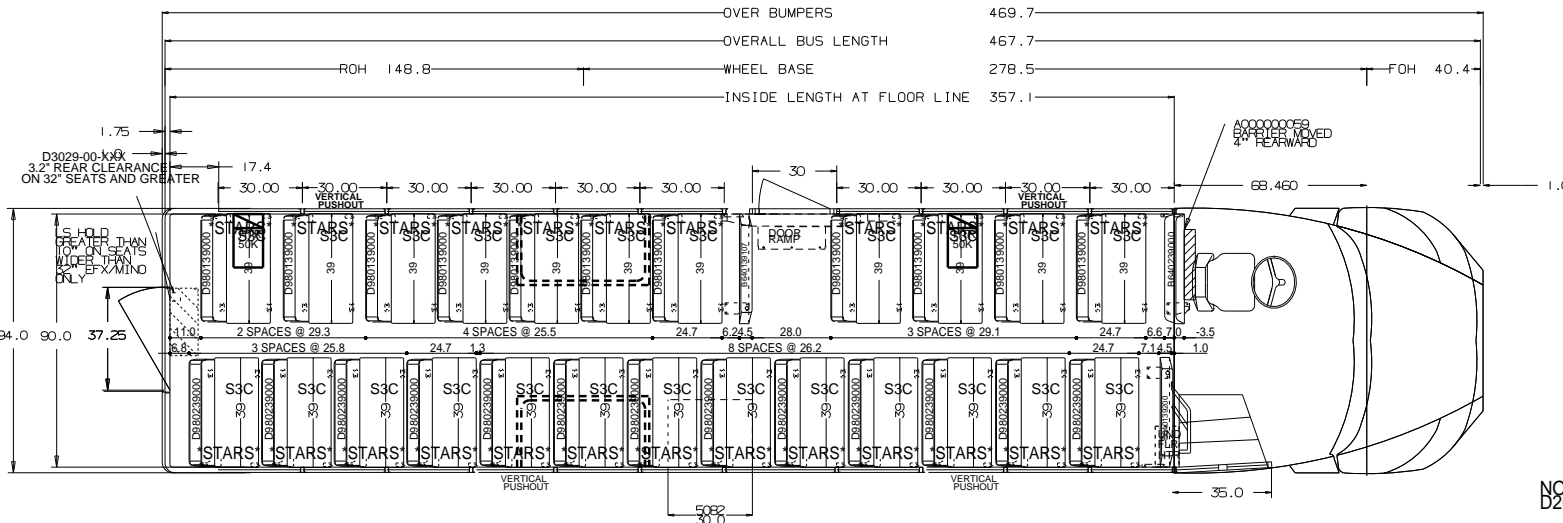

NOTES:  
D20000805 - LS DOOR LOC. NO 5 (10\"/>

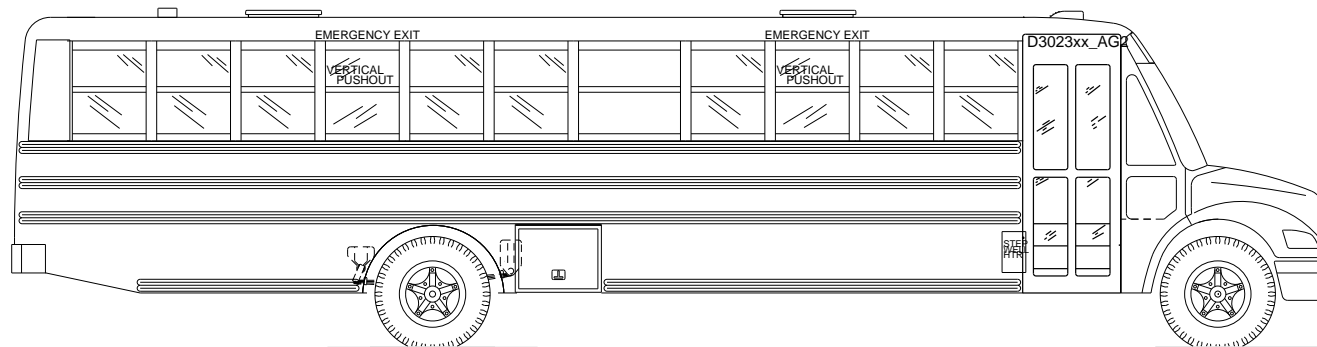

ALL DIMENSIONS ARE FOR REFERENCE ONLY

GENERAL NOTES

- 1. SOME ITEMS, SUCH AS CV MIRRORS, ROOF LUGGAGE RACKS, AND OTHER ITEMS, ARE SHOWN IN ONE VIEW ONLY FOR CLARITY. THIS DRAWING IS A REPRESENTATION ONLY AND MAY NOT HAVE ALL ITEMS REQUIRED. PLEASE REFER TO ORDER!
- 2. THE CLEARANCE BETWEEN BOTTOM OF BUS OR BOTTOM OF UNDERBODY COMPARTMENTS AND GROUND WILL VARY ACCORDING TO TIRE SIZE, BUS LOAD, AND SUSPENSION TYPE.
- 3. THE NOMINAL BUS HEIGHT IS BASED ON STANDARD RAILS IS 96\"/>
- 4. THE MAXIMUM WIDTH AT BELT LINE OVER GUARD RAILS IS 96\"/>
- 5. BODY AND LARGEST SIZE TIRE.
- 6. THE MAXIMUM BUS HEIGHT IS BASED ON BODY WITH OPTIONS SUCH AS A/C UNITS, STROBE LIGHT, CARGO SUSPENSION ETC.
- 7. OVER BUMPER DIMENSION DOES NOT TAKE INTO ACCOUNT OPTIONS THAT MAY ADD TO THE TOTAL LENGTH OF THE BUS, SUCH AS MIRRORS, LIGHTS AND CROSSING ARMS.

Model: Saf-T-Liner C2  
Quote Number: 388073  
Locality: KY

THIS DRAWING AND ALL INFORMATION PROVIDED WITH IT ARE THE PROPERTY OF THOMAS BUILT BUSES, INC. ANY REPRODUCTION OR DISTRIBUTION OF THIS MATERIAL OR ANY PART WITHOUT WRITTEN PERMISSION OF THOMAS BUILT BUSES, INC. IS STRICTLY PROHIBITED. COPYRIGHT THOMAS BUILT BUSES, INC.

SIDE	ROW	SPACING	WHEEL RADIUS
LEFT		29.1	27.8
LEFT		25.5	24.2
LEFT		29.3	28.0
RIGHT		26.2	24.9
RIGHT		25.8	24.5

  

TITLE		PLAN AND ELEVATION BODY 340TS	
DRN:06-10-22	BY:T. Dean	SIZE	DWG. NO.
SCALE	3/8"=12"	S	860229

THOMAS BUILT BUSES, INC  
HIGH POINT, NC

ITEM # TH16  
 CUMMINS DIESEL  
 260 HP  
 3000 PTS  
 CAPACITY 70  
 WHEEL BASE - 212  
 FORWARD CONTROL

# SEATING CAPACITY: 70 + DRIVER

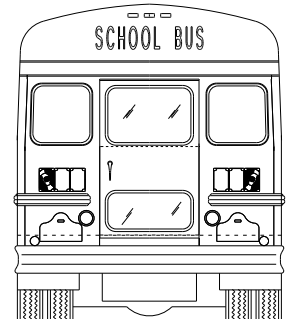
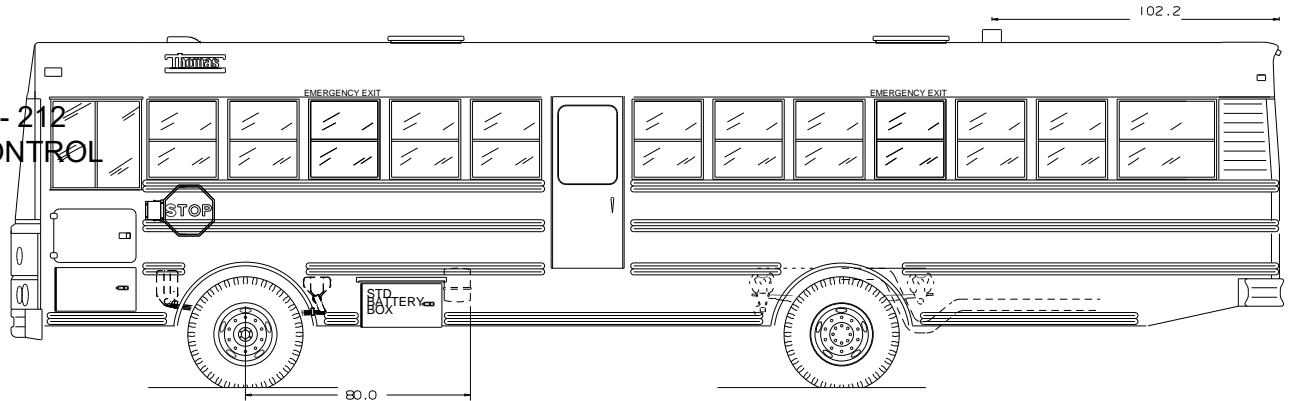

CAUTION - LEFT SIDE BARRIER IS NOT IN STANDARD LOCATION, SEE SEATING PLAN.  
 CAUTION - RIGHT SIDE BARRIER IS NOT IN STANDARD LOCATION, SEE SEATING PLAN.

## EQUIPPED WITH 23K SUSPENSION

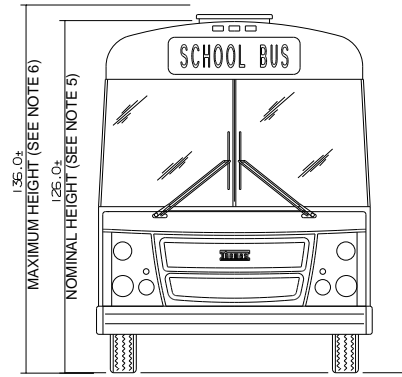
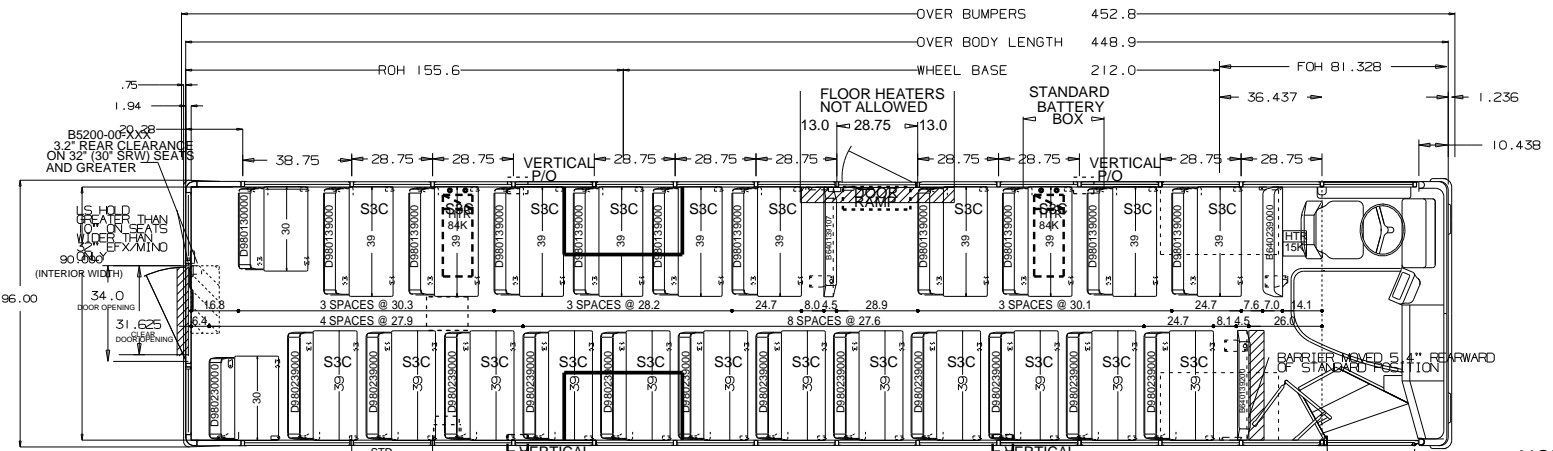

NOTES:  
 \*\*\*EFX UNIT\*\*\*  
 \*\*\*23K REAR SUSPENSION\*\*\*

## COLORADO RACKING UNIT

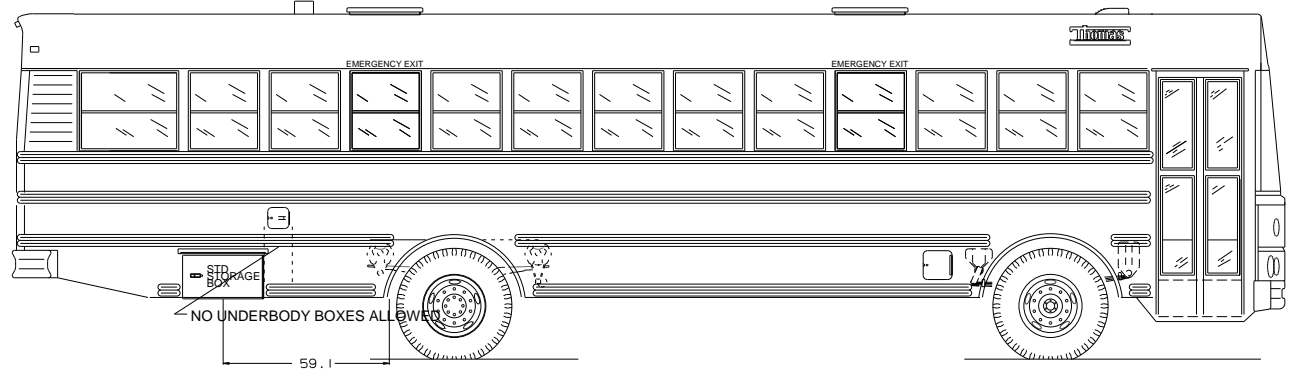

### ALL DIMENSIONS ARE FOR REFERENCE ONLY

Model: MVP-EF  
 Quote Number: 388037  
 Locality: KY

- GENERAL NOTES**
- SOME ITEMS, SUCH AS CV MIRRORS, ROOF LUGGAGE RACKS, AND OTHER ITEMS, ARE SHOWN IN ONE VIEW ONLY FOR CLARITY.
  - THIS DRAWING IS A REPRESENTATION ONLY AND MAY NOT HAVE ALL ITEMS REQUIRED. PLEASE REFER TO ORDER!
  - 3" CLEARANCE BETWEEN BOTTOM OF BUS OR BOTTOM OF UNDERBODY COMPARTMENTS AND GROUND WILL VARY ACCORDING TO TIRE SIZE, BUS LOAD, AND SUSPENSION TYPE.
  - THE MAXIMUM WIDTH AT BELT LINE OVER GUARD RAILS IS 36".
  - THE NOMINAL BUS HEIGHT IS BASED ON A STANDARD BODY AND LARGEST SIZE TIRE.
  - THE MAXIMUM BUS HEIGHT IS BASED ON BODY WITH OPTIONS SUCH AS A/C UNITS, STROBE LIGHT, LARGER SUSPENSION ETC.
  - OVER BUMPER DIMENSION DOES NOT TAKE INTO ACCOUNT OPTIONS THAT MAY ADD TO THE TOTAL LENGTH OF THE BUS, SUCH AS MIRRORS, LIGHTS, AND CROSSING ARMS.
- THIS DRAWING AND ALL INFORMATION PROVIDED WITH IT ARE THE PROPERTY OF THOMAS BUILT BUSES, INC. ANY REPRODUCTION OR DISTRIBUTION OF THIS MATERIAL OR ANY PART WITHOUT WRITTEN PERMISSION OF THOMAS BUILT BUSES, INC. IS STRICTLY PROHIBITED. COPYRIGHT THOMAS BUILT BUSES, INC.

SIDE	ROW	SPACING	SEAT WIDTH	SEAT DEPTH
LEFT		30.1	28.8	
LEFT		28.2	26.9	
LEFT		30.3	29.0	
RIGHT		27.6	26.3	
RIGHT		27.9	26.6	

THOMAS BUILT BUSES, INC  
 HIGH POINT, NC

TITLE: PLAN AND ELEVATION BODY 1318S

DRN: 05-24-22 BY: T. Dean SIZE: DWG. NO.  
 SCALE: 3/8"=12" S 859381

ITEM # TH17  
 CUMMINS DIESEL  
 260 HP  
 3000 PTS  
 CAPACITY 74  
 WHEEL BASE - 212  
 FORWARD CONTROL

# SEATING CAPACITY: 74 + DRIVER

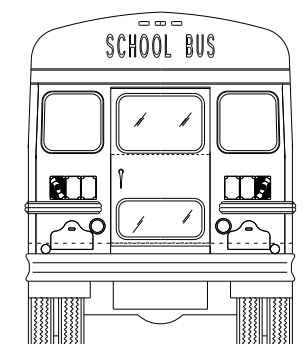
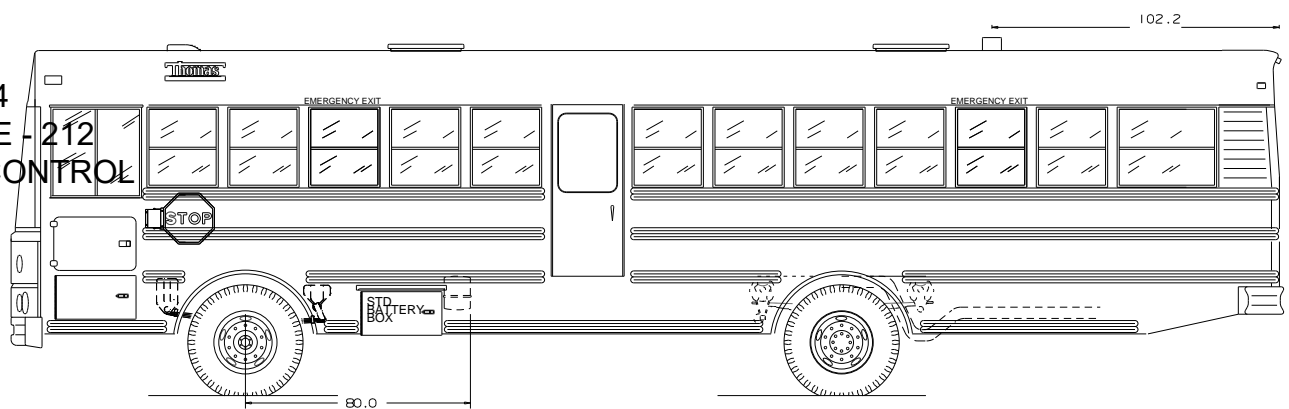

CAUTION - LEFT SIDE BARRIER IS NOT IN STANDARD LOCATION, SEE SEATING PLAN.  
 CAUTION - RIGHT SIDE BARRIER IS NOT IN STANDARD LOCATION, SEE SEATING PLAN.

## EQUIPPED WITH 23K SUSPENSION

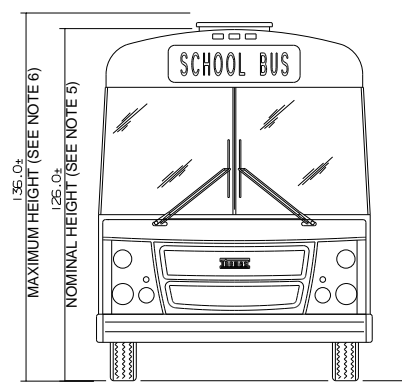
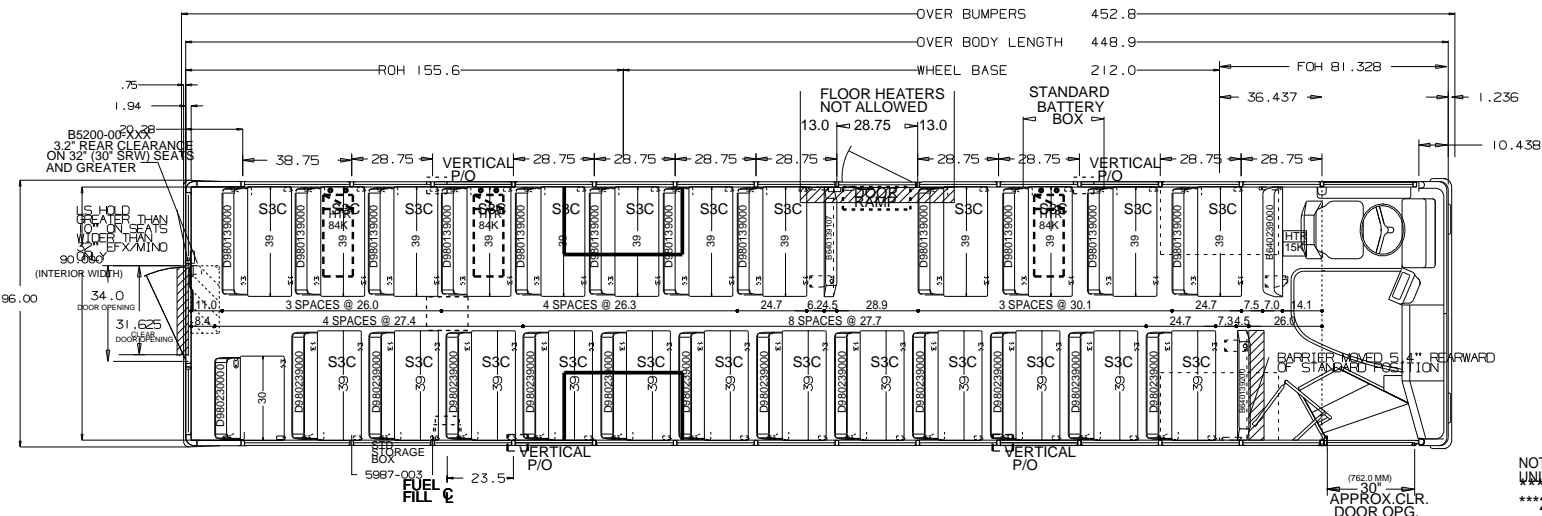

NOTES:  
 \*\*EQUIPPED WITH PLYWOOD FLOOR  
 \*\*23K SUSPENSION\*\*

## COLORADO RACKING UNIT

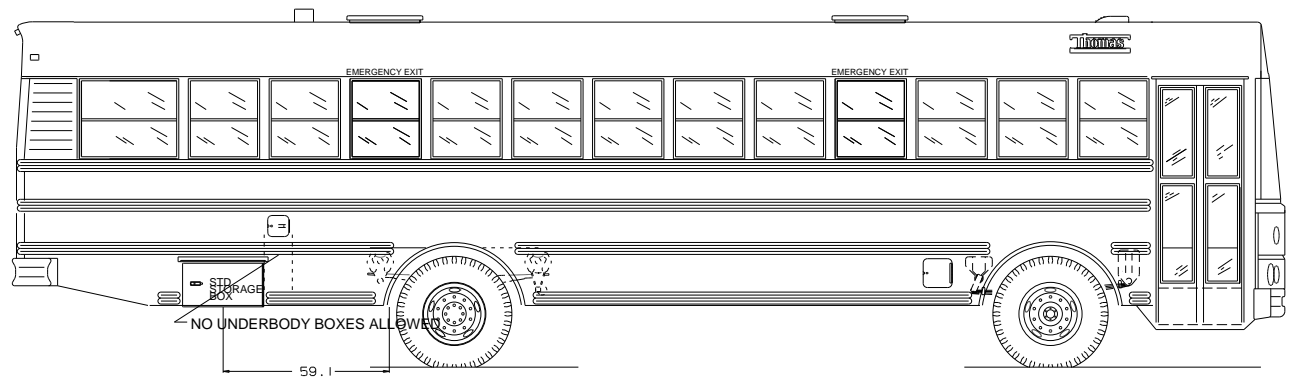

ALL DIMENSIONS ARE FOR REFERENCE ONLY

Model: MVP-EF  
 Quote Number: 388040  
 Locality: KY

- GENERAL NOTES
- SOME ITEMS, SUCH AS CV MIRRORS, ROOF LUGGAGE RACKS, AND OTHER ITEMS, ARE SHOWN IN ONE VIEW ONLY FOR CLARITY.
  - THIS DRAWING IS A REPRESENTATION ONLY AND MAY NOT HAVE ALL ITEMS REQUIRED. PLEASE REFER TO ORDER.
  - CLEARANCE BETWEEN BOTTOM OF BUS OR BOTTOM OF UNDERBODY COMPARTMENTS AND GROUND WILL VARY ACCORDING TO TIRE SIZE, BUS LOAD, AND SUSPENSION TYPE.
  - THE MAXIMUM BUS HEIGHT AT BELT LINE OVER GUARD RAILS IS 36".
  - THE MAXIMUM BUS HEIGHT IS BASED ON A STANDARD BODY AND LARGEST SIZE TIRE.
  - THE MAXIMUM BUS HEIGHT IS BASED ON BODY WITH OPTIONS SUCH AS A/C UNITS, STROBE LIGHT, LARGER SUSPENSION ETC.
  - OVER BUMPER DIMENSION DOES NOT TAKE INTO ACCOUNT OPTIONS THAT MAY ADD TO THE TOTAL LENGTH OF THE BUS, SUCH AS MIRRORS, LIGHTS, AND CROSSING ARMS.
- THIS DRAWING AND ALL INFORMATION PROVIDED WITH IT ARE THE PROPERTY OF THOMAS BUILT BUSES, INC. ANY REPRODUCTION OR DISTRIBUTION OF THIS MATERIAL OR ANY PART WITHOUT WRITTEN PERMISSION OF THOMAS BUILT BUSES, INC. IS STRICTLY PROHIBITED. COPYRIGHT THOMAS BUILT BUSES, INC.

SIDE	ROW	SPACING	SEAT SPACING	SEAT WIDTH
LEFT		30.1	28.8	
LEFT		26.3	25.0	
LEFT		28.0	24.7	
RIGHT		27.7	26.4	
RIGHT		27.4	26.1	

TITLE: PLAN AND ELEVATION BODY 1318S  
 DRN: 05-24-22 BY: T. Dean  
 SCALE: 3/8"=12" SIZE: DWG. NO. S 859384

ITEM # TH18  
 CUMMINS DIESEL  
 260 HP  
 3000 PTS  
 CAPACITY 78  
 WHEELBASE - 231  
 FORWARD CONTROL

# SEATING CAPACITY: 78 + DRIVER

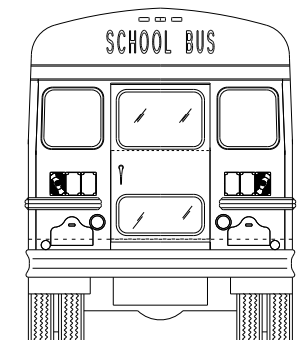
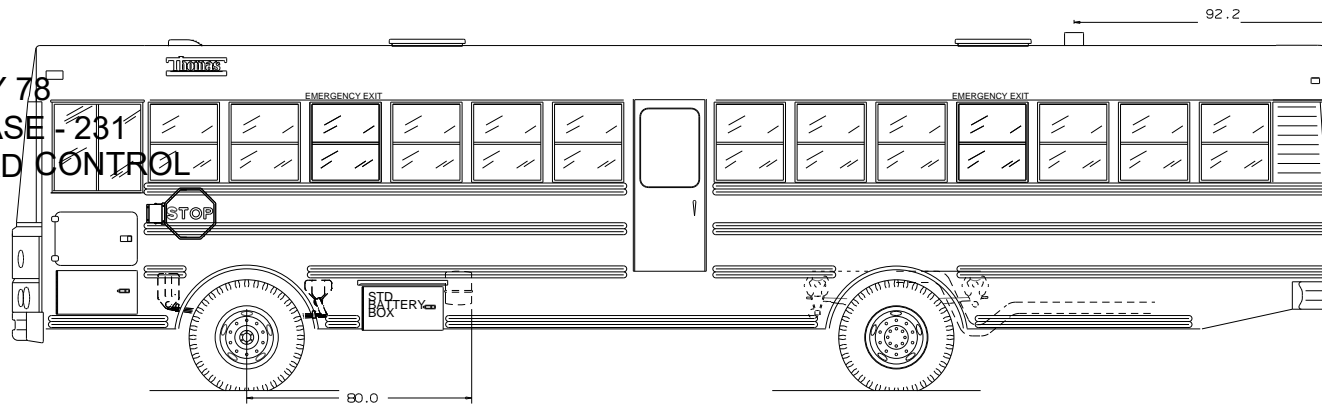

CAUTION - LEFT SIDE BARRIER IS NOT IN STANDARD LOCATION, SEE SEATING PLAN.  
 CAUTION - RIGHT SIDE BARRIER IS NOT IN STANDARD LOCATION, SEE SEATING PLAN.

## EQUIPPED WITH 23K SUSPENSION

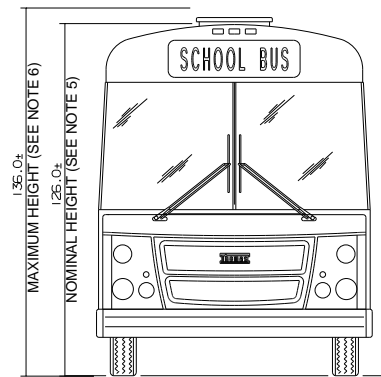
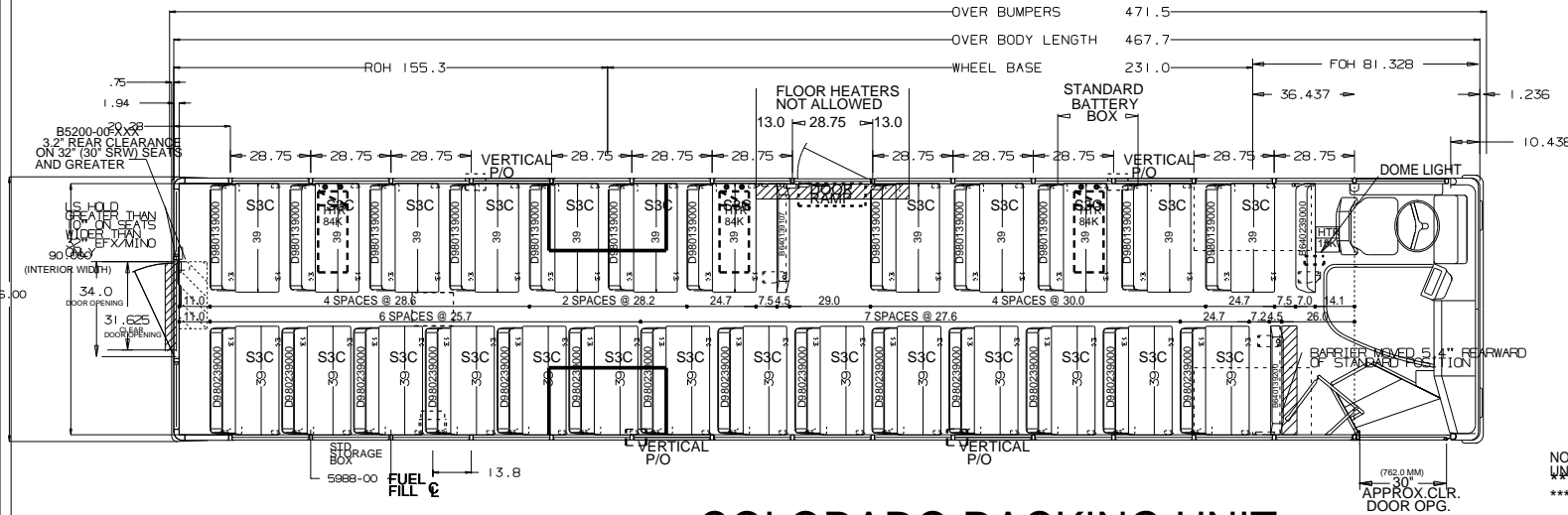

NOTES:  
 \*\*EQUIPPED WITH PLYWOOD FLOOR  
 \*\*23K SUSPENSION\*\*

## COLORADO RACKING UNIT

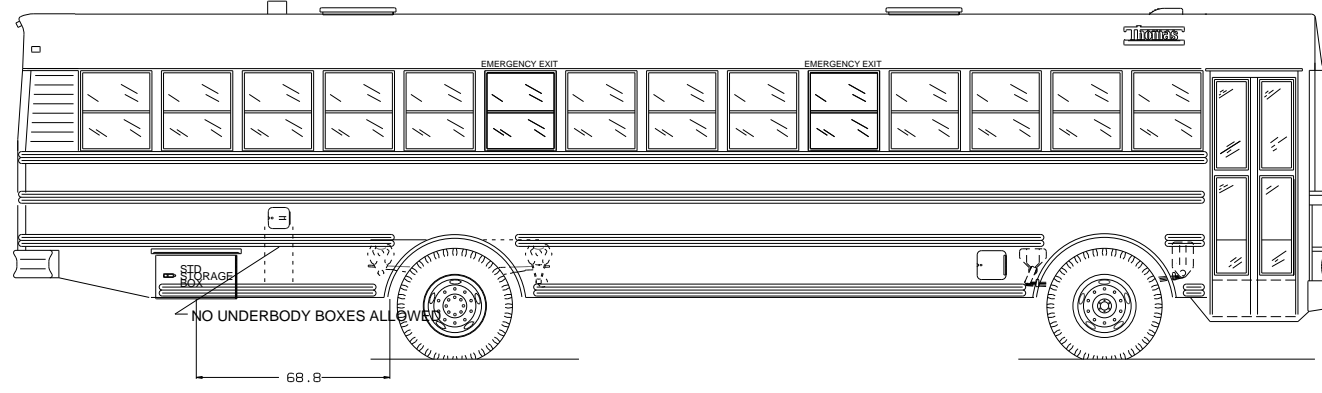

ALL DIMENSIONS ARE FOR REFERENCE ONLY

Model: MVP-EF  
 Quote Number: 388041  
 Locality: KY

- GENERAL NOTES**
- SOME ITEMS, SUCH AS CV MIRRORS, ROOF LUGGAGE RACKS, AND OTHER ITEMS, ARE SHOWN IN ONE VIEW ONLY. NOT ALL ITEMS REQUIRED.
  - THIS DRAWING IS A REPRESENTATION ONLY AND MAY NOT HAVE ALL ITEMS REQUIRED.
  - PLEASE REFER TO ORDER!
  - CLEARANCE BETWEEN BOTTOM OF BUS OR BOTTOM OF UNDERBODY COMPARTMENTS AND GROUND WILL VARY ACCORDING TO TIRE SIZE, BUS LOAD, AND SUSPENSION TYPE.
  - THE MAXIMUM WIDTH AT BELT LINE OVER GUARD RAILS IS 36".
  - THE MAXIMUM BUS HEIGHT IS BASED ON A STANDARD BODY AND LARGEST TIRE SIZE.
  - THE MAXIMUM BUS HEIGHT IS BASED ON BODY WITH OPTIONS SUCH AS A/C UNITS, STROBE LIGHT, LARGER SUSPENSION ETC.
  - OVER BUMPER DIMENSION DOES NOT TAKE INTO ACCOUNT OPTIONS THAT MAY ADD TO THE TOTAL LENGTH OF THE BUS, SUCH AS MIRRORS, LIGHTS, AND CROSSING ARMS.
- THIS DRAWING AND ALL INFORMATION PROVIDED WITH IT ARE THE PROPERTY OF THOMAS BUILT BUSES, INC. ANY REPRODUCTION OR DISTRIBUTION OF THIS MATERIAL OR ANY PART WITHOUT WRITTEN PERMISSION OF THOMAS BUILT BUSES, INC. IS STRICTLY PROHIBITED. COPYRIGHT THOMAS BUILT BUSES, INC.

SIDE	ROW	SPACING	SEAT WIDTH	SEAT DEPTH
LEFT		30.0	28.7	
LEFT		28.2	26.9	
LEFT		28.8	27.3	
RIGHT		27.6	26.3	
RIGHT		25.7	24.4	

  

TITLE	PLAN AND ELEVATION BODY 1408S		
DRN-05-20-22	BY: T. Dean	SIZE	DWG. NO.
SCALE	3/8"=12"	S	859385



# SEATING CAPACITY: 78 + DRIVER

ITEM # TH19  
 CUMMINS DIESEL  
 240 HP  
 3000 PTS  
 CAPACITY  
 78  
 WHEELBASE  
 267  
 REAR ENGINE

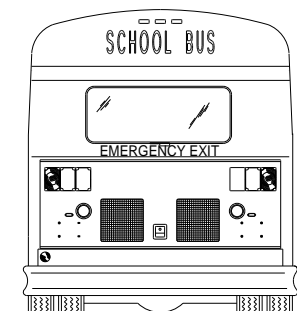
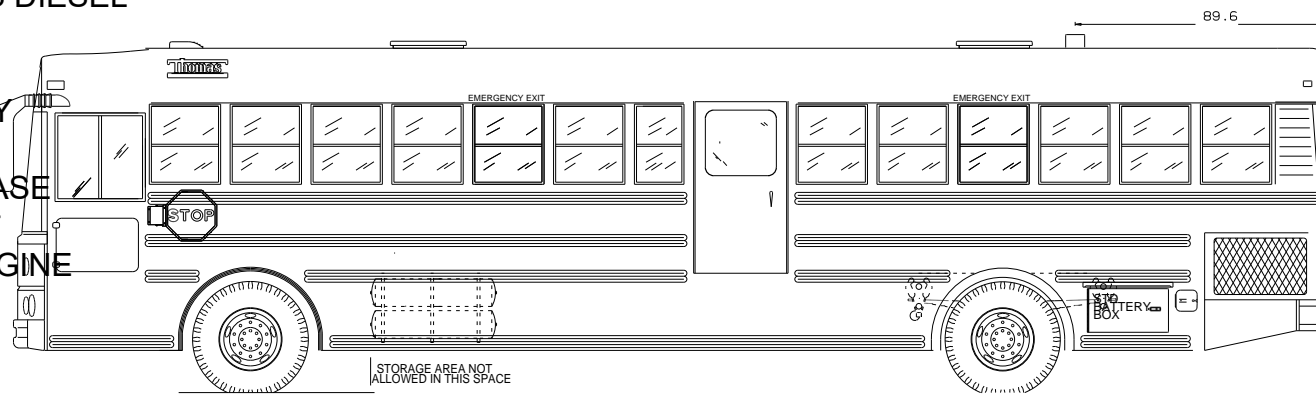

CAUTION - LEFT SIDE BARRIER IS NOT IN STANDARD LOCATION, SEE SEATING PLAN.  
 CAUTION - RIGHT SIDE BARRIER IS NOT IN STANDARD LOCATION, SEE SEATING PLAN.

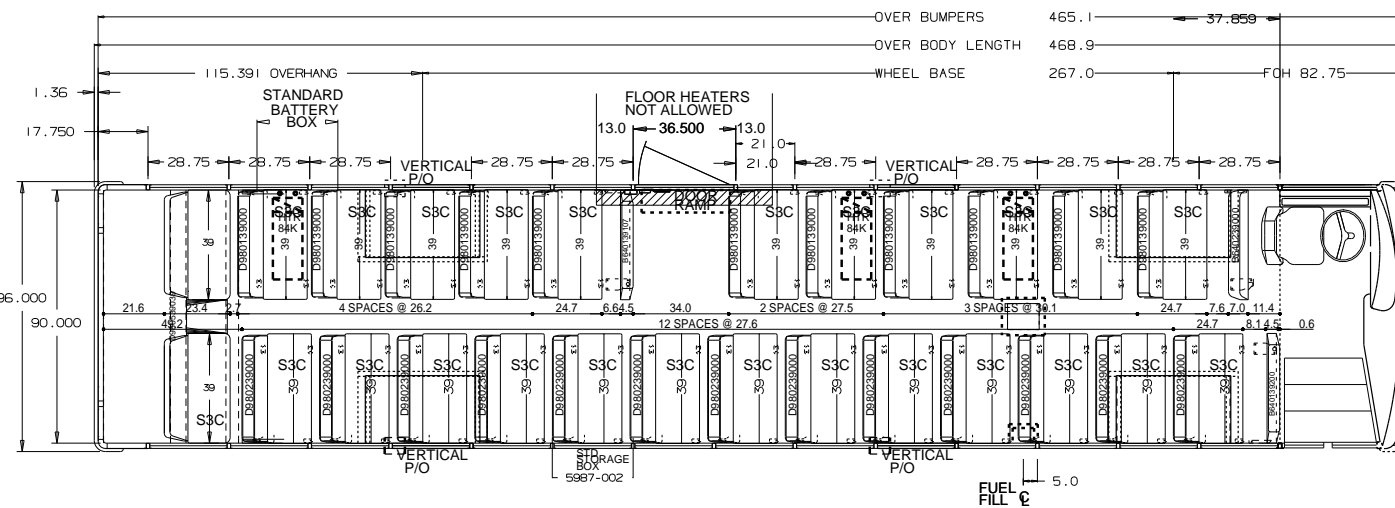

EQUIPPED WITH ALLISON TRANSMISSION

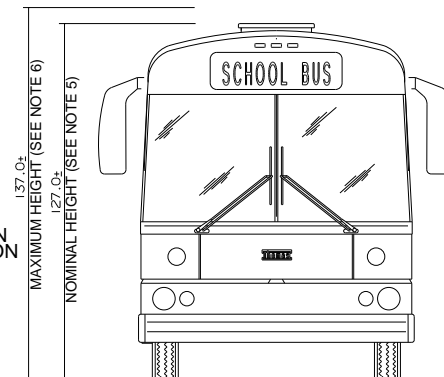

NOTES:  
 UNIT EQUIPPED WITH PLYWOOD FLOOR

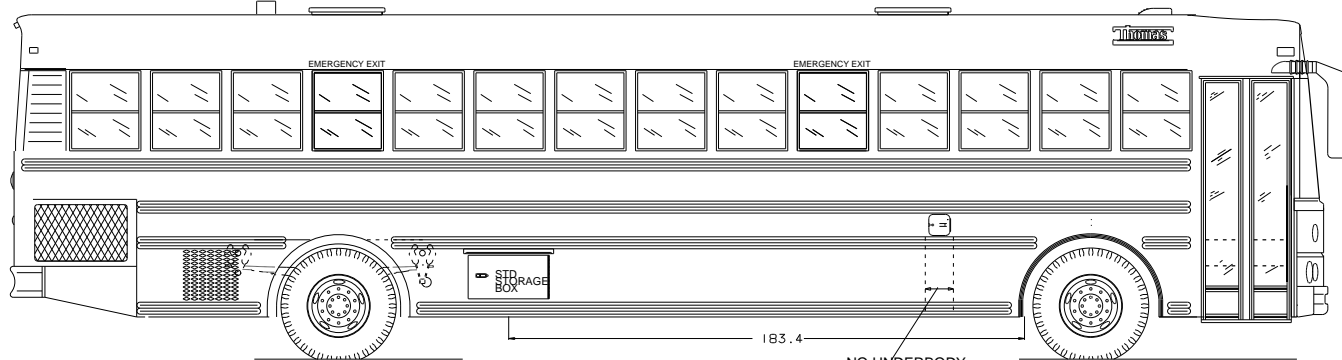

**ALL DIMENSIONS ARE FOR REFERENCE ONLY**

Model: Saf-T-Liner HDX  
 Quote Number: 388043  
 Locality: KY

- GENERAL NOTES**
- SOME ITEMS, SUCH AS CV MIRRORS, ROOF LUGGAGE RACKS, AND OTHER ITEMS, ARE SHOWN IN ONE VIEW ONLY FOR CLARITY.
  - THIS DRAWING IS A REPRESENTATION AND MAY NOT HAVE ALL ITEMS REQUIRED. PLEASE REFER TO ORDER!
  - THE CLEARANCE BETWEEN BOTTOM OF BUS OR BOTTOM OF UNDERBODY COMPARTMENTS AND GROUND WILL VARY ACCORDING TO TIRE SIZE, BUS LOAD, AND SUSPENSION TYPE.
  - THE MAXIMUM WIDTH AT BELT LINE OVER GUARD RAILS IS 96".
  - THE MAXIMUM BUS HEIGHT IS BASED ON A STANDARD BODY AND LARGEST TIRE SIZE.
  - THE MAXIMUM BUS HEIGHT IS BASED ON BODY WITH OPTIONS SUCH AS A/C UNITS, STROBE LIGHT, CARRIER SUSPENSION ETC.
  - OVER BUMPER DIMENSION DOES NOT TAKE INTO ACCOUNT OPTIONS THAT MAY ADD TO THE TOTAL LENGTH OF THE BUS, SUCH AS MIRRORS, LIGHTS AND CROSSING ARMS.
- THIS DRAWING AND ALL INFORMATION PROVIDED WITH IT ARE THE PROPERTY OF THOMAS BUILT BUSES, INC. ANY REPRODUCTION OR DISTRIBUTION OF THIS MATERIAL OR ANY PART WITHOUT WRITTEN PERMISSION OF THOMAS BUILT BUSES, INC. IS STRICTLY PROHIBITED. COPYRIGHT THOMAS BUILT BUSES, INC.

SIDE	ROW	SPACING	WHEEL SPACING
LEFT		30.1	28.8
LEFT		27.5	26.2
LEFT		26.2	24.9
RIGHT		27.6	26.3

TITLE: **PLAN AND ELEVATION BODY 140YS**  
 DRN:06-10-22 BY:T. Dean  
 SCALE 3/8"=12" SIZE DWG. NO. S 860233  
 Program Version: 22.4.4

# SEATING CAPACITY: 84 + DRIVER

ITEM # TH20  
 CUMMINS DIESEL  
 240 HP  
 3000 PTS  
 CAPACITY 84  
 WHEELBASE 267  
 REAR ENGINE

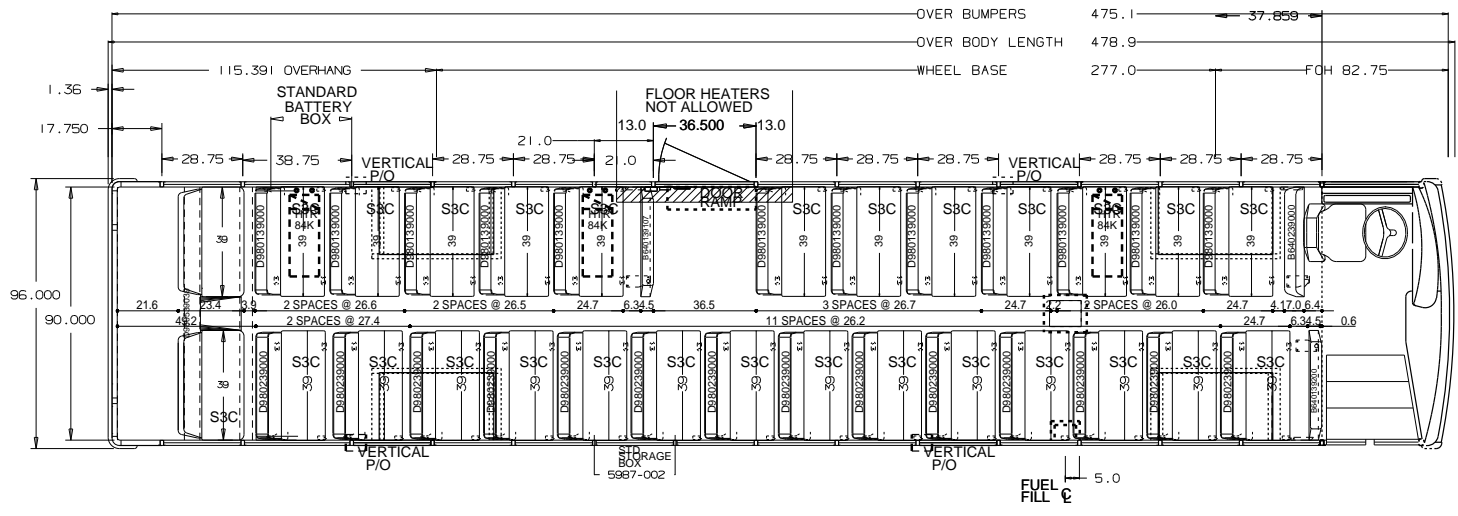
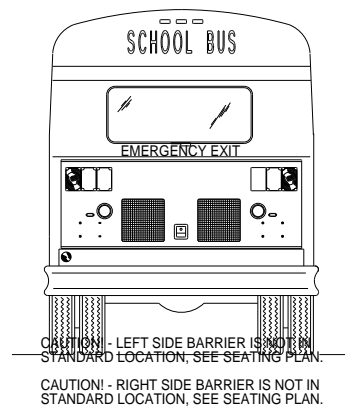
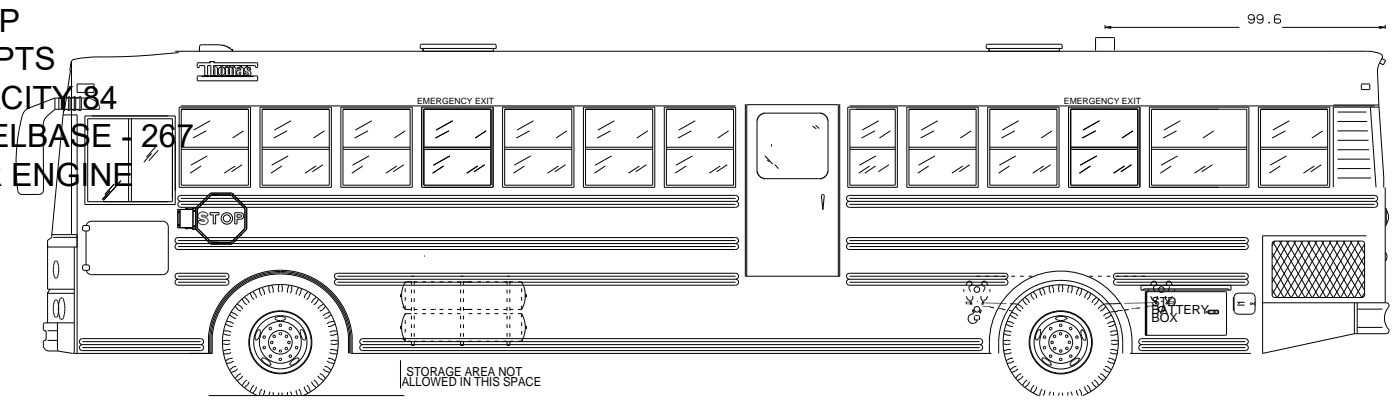

EQUIPPED WITH ALLISON TRANSMISSION

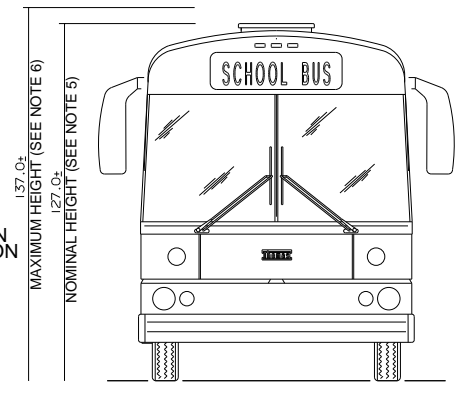

NOTES:  
 UNIT EQUIPPED WITH PLYWOOD FLOOR

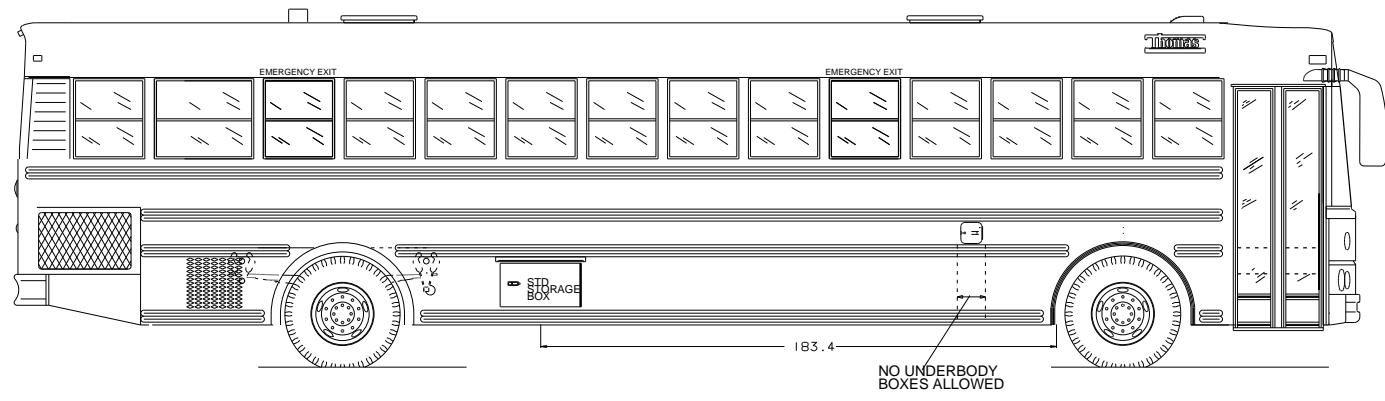

**ALL DIMENSIONS ARE FOR REFERENCE ONLY**

**GENERAL NOTES**

- SOME ITEMS, SUCH AS CV MIRRORS, ROOF LUGGAGE RACKS, AND OTHER ITEMS, ARE SHOWN IN ONE VIEW ONLY FOR CLARITY.
- THIS DRAWING IS A REPRESENTATION ONLY AND MAY NOT HAVE ALL ITEMS REQUIRED. PLEASE REFER TO ORDER!
- THE CLEARANCE BETWEEN BOTTOM OF BUS OR BOTTOM OF UNDERBODY COMPARTMENTS AND GROUND WILL VARY ACCORDING TO TIRE SIZE, BUS LOAD, AND SUSPENSION TYPE.
- THE MAXIMUM WIDTH AT BELT LINE OVER GUARD RAILS IS 96".
- THE MAXIMUM BUS HEIGHT IS BASED ON A STANDARD BODY AND LARGEST TIRE SIZE.
- THE MAXIMUM BUS HEIGHT IS BASED ON BODY WITH OPTIONS SUCH AS A/C UNITS, STROBE LIGHT, CARRIER SUSPENSION ETC.
- OVER BUMPER DIMENSION DOES NOT TAKE INTO ACCOUNT OPTIONS THAT MAY ADD TO THE TOTAL LENGTH OF THE BUS, SUCH AS MIRRORS, LIGHTS AND CROSSING ARMS.

Model: Saf-T-Liner HDX  
 Quote Number: 388044  
 Locality: KY

THIS DRAWING AND ALL INFORMATION PROVIDED WITH IT ARE THE PROPERTY OF THOMAS BUILT BUSES, INC. ANY REPRODUCTION OR DISTRIBUTION OF THIS MATERIAL OR ANY PART WITHOUT WRITTEN PERMISSION OF THOMAS BUILT BUSES, INC. IS STRICTLY PROHIBITED. COPYRIGHT THOMAS BUILT BUSES, INC.

SIDE	ROW	SPACING	SEAT SPACING	SEAT WIDTH
LEFT		26.0	24.7	
LEFT		26.7	25.4	
LEFT		26.3	25.2	
LEFT		26.6	25.3	
RIGHT		26.2	24.9	
RIGHT		27.4	26.1	

**THOMAS BUILT BUSES, INC**  
 HIGH POINT, NC  
 TITLE: **PLAN AND ELEVATION BODY 141YS**  
 DRN: 06-10-22 BY: T. Dean SIZE: DWG. NO.  
 SCALE: 3/8"=12" S 860231