



# Number and Operations in Base Ten: What is the Value of the Place? Grade 2 Formative Assessment Lesson

Designed and revised by the Kentucky Department of Education  
Field-tested by Kentucky Mathematics Leadership Network Teachers

Rights and Usage Agreement: <https://creativecommons.org/licenses/by/4.0/>

If you encounter errors or other issues with this file, please contact the KDE math team at:  
[kdemath@education.ky.gov](mailto:kdemath@education.ky.gov)

Revised 2019

This Formative Assessment Lesson is designed to be part of an instructional unit. This task should be implemented approximately two-thirds of the way through the instructional unit. The results of this task should be used to inform the instruction that will take place for the remainder of your unit.

## Mathematical goals

This lesson is intended to help you assess how well students are able to recognize the value of the place in a number. It will help you to identify students who have the following difficulties:

- Recognizing place value of ones, tens, hundreds.
- Use correct mathematical vocabulary to explain place value to a partner.
- Make connections of place value to previously taught lessons.

## Kentucky Academic Standards

This lesson involves mathematical content standards within the grade, with emphasis on:

### Grade 2 Number and Operations in Base Ten

**Cluster:** Understand place value.

This lesson involves a range of Standards for Mathematical Practice, with emphasis on:

**MP2.** Reason abstractly and quantitatively.

**MP7.** Look for and make use of structure.

## Introduction

This lesson is structured in the following way:

- Before the lesson, students work individually on an assessment task that is designed to reveal their current understandings and difficulties. You then review their work and create questions for students to answer in order to improve their solutions.
- Students work in pairs on collaborative discussion tasks to represent 3-digit numbers in multiple ways. Throughout their work, students justify and explain their decisions to their peers.
- Students return to their original assessment tasks, and try to improve their own responses.

## Materials required

Each individual student will need:

- Two copies of the assessment task *What's the Value?*
- *Mini white board, marker, eraser*

Each pair of students will need the following resources:

- Card Set A numeral cards with Card Set A Base Ten Cards
- Dry erase marker/eraser if cards are laminated
- A set of arrow cards (arrow cards can be found at this link):  
[http://www.reneeyates2math.com/uploads/1/3/0/5/13052484/arrow\\_cards\\_packet\\_revised\\_2011\\_10\\_14.pdf](http://www.reneeyates2math.com/uploads/1/3/0/5/13052484/arrow_cards_packet_revised_2011_10_14.pdf)
- Card Set B numeral cards with Card Set B Base Ten Cards

## Time needed

Approximately 15 minutes before the lesson for the individual assessment task, one 40 minute lesson, and 15 minutes for a follow-up lesson for students to revisit individual assessment task. Timings given are approximated. All students need not complete all sets of cards activities. Exact timings will depend on the needs of the class.

## Before the Lesson

### Assessment task: What's the Value (15 minutes)

Have students do this task individually in class a day or more before the formative assessment lesson. This will give you an opportunity to assess the work, and to find out the kinds of difficulties students have with it. You will be able to target your help more effectively in the follow-up lesson.

### Framing the pre-assessment:

Give each student a copy of the assessment task

**Teacher says:** *Today we are going to work on a task about place value. Look at the number at the top of your paper. Circle all the statements in the boxes that are true about the number. Explain why you think each statement is true or why you think it is not true. If you are not sure about all of your answers, it is okay. We are going to do an activity that will help you get better at place value.*

What's the Value? Name _____	
<b>243</b>	
Circle <b>all</b> the true statements about this number and explain your thinking.	
A) 2 tens and 43 ones	B) 243 ones
C) 2 hundreds 403 ones	D) 24 tens and 3 ones
E) 2 hundreds and 43 ones	F) 3 hundred and 243 ones
<small>Student Materials</small>	

It is important that the students are allowed to answer the questions without your assistance, as far as possible.

Students should not worry too much if they do not understand or cannot do everything, because in the next lesson they will engage in tasks, which should help them. Explain to students that by the end of the next lesson, they should expect to answer questions such as these confidently.

### Assessing students' responses

Collect students' responses to the task. Make some notes about what their work reveals about their current levels of understanding, and their different problem solving approaches.

We suggest that you do not score student's work. The research shows that this will be counterproductive, as it will encourage students to compare their scores, and will distract their attention from what they can do to improve their mathematics.

Instead, help students to make further progress by summarizing their difficulties as a series of questions. Some questions on the following page may serve as examples. These questions have been drawn from commonly identified student misconceptions.

We suggest that you write a list of your own questions, based on your students' work, using, but not limited to the ideas that follow. You may choose to write questions on each student's work. If you do not have time to do this, select a few questions that will be of help to the majority of students. These can be written/displayed on the board at the end of the lesson before the students are given the post assessment task.

The solution to these difficulties is not to teach one particular way of showing or determining the value of a multi-digit number, but to help students explore and discover a variety of ways that work in different situations and make sense to them.

Below is a list of common issues and questions/prompts that may be written on individual tasks or asked during the collaborative activity to help students clarify and extend their thinking. Add your own student misconceptions and questions to the chart in the blank spaces.

Common Issues:	Suggested questions and prompts:
<p><b>Students group cards based on hundred place only.</b></p>	<ul style="list-style-type: none"> <li>• Why do you think those are a match?</li> <li>• I see that number is 362 and there are 3 hundred flats represented, but what about the rest of the blocks, did you count all those too?</li> <li>• How are you tracking that you have counted all the blocks?</li> <li>• Is there a way we can make sure we have counted everything?</li> </ul>
<p><b>Students select the wrong arrow cards. For example, if the number is 243, the students may use the 2...4....and 3 rather than 200...40...3.</b></p>	<ul style="list-style-type: none"> <li>• Did you line your arrows up?</li> <li>• What does it mean when we line our arrows up and the numbers cover each other up?</li> <li>• Look at your 2, what is the value of the two in your number and what is the value on your arrow card?</li> </ul>
<p><b>Drawings are not represented correctly in set C.</b></p>	<ul style="list-style-type: none"> <li>• How are you tracking that you have counted all the blocks?</li> <li>• Is there a way we can make sure we have counted everything?</li> </ul>

## Suggested lesson outline

### Whole Class Introduction (10 minutes)

**Teacher says:** *Today we are going to do some more work with the value of place. Here are some different representations of a three digit number.*

Project the first image below (see page 9). Instruct students to select all the representations of 315. Next project the second image below (page 10). Ask students to reason why which box doesn't belong. Discuss mathematical reasoning.

Circle all correct representations of 315.

The image shows a 2x2 grid of boxes. Each box contains different representations of the number 315. The top-left box shows three groups of ten flats (100s), one ten rod (10), and five ones units (5). The top-right box shows three flats (100s), one ten rod (10), and five ones units (5). The bottom-left box shows three flats (100s), one ten rod (10), and five ones units (5). The bottom-right box shows three flats (100s), one ten rod (10), and five ones units (5).

Which of these doesn't belong?

The image shows a 2x2 grid of boxes. Each box contains different representations of the number 315. The top-left box shows two flats (100s), one ten rod (10), and five ones units (5). The top-right box shows one flat (100), four ten rods (40), and five ones units (5). The bottom-left box shows two flats (100s), four ten rods (40), and five ones units (5). The bottom-right box shows one flat (100), eight ten rods (80), and five ones units (5).

## **Collaborative Activity: Match Base Ten Representations and Build Numbers with Arrow Cards**

Strategically partner students based on pre assessment data. Partner students with others who display similar errors/misconceptions on the pre-assessment task. While this may seem counterintuitive, this will allow each student to more confidently share their thinking. This may result in partnering students who were very successful together, those who did fairly well together, and those who did not do very well together.

Give each pair Set A of numeral cards, arrow cards, and base ten cards.

Introduce the lesson carefully:

**Teacher says:** *I want you to work as a pair. Match each of the base ten cards to the correct numeral card. Take turns building the numeral using the arrow cards. Each time you do this, explain your thinking clearly to your partner. If your partner disagrees with your placement then challenge him or her to explain why. It is important that you both understand why each card is placed where it is. There is a lot of work to do today and you may not all finish. The important thing is to learn something new, so take your time.*

Your tasks during the partner work are to make a note of student approaches to the task, and to support student problem solving. As you monitor the work, listen to the discussion and ask questions to help students understand concepts and clarify misconceptions and to look for patterns and generalizations.

### **Make a note of student approaches to the task**

You can then use this information to focus a whole-class discussion towards the end of the lesson. In particular, notice any common mistakes. Partners should be engaged in checking their partner, asking for clarification, and taking turns. When calling on students make sure you allow the struggling pairs to share first.

### **Support student problem solving**

Try not to make suggestions that move students toward a particular approach to the task. Instead, ask questions to help students clarify their thinking. Encourage students to use each other as a resource for learning.

If one student has built a number in a particular way, challenge their partner to provide an explanation.

If you find students have difficulty articulating their decisions, then you may want to use the questions from the *Common Issues* table to support your questioning.

If the whole class is struggling on the same issue, then you may want to write a couple of questions on the board and organize a whole class discussion.

### **Place Card Set B**

As students finish with matching Place Card Set A and can explain their work, hand out Card Set B. These are developed to be more difficult. There are three representations of each number using base ten cards which manipulate the tens and ones.

Do not collect Place Card Set A. An important part of this task is for students to make connections between different ways of building the numerals.

As you monitor the work, listen to the discussion and help students to look for patterns and generalizations.

### **Place Card Set C**

As students finish with Card Set B and can explain their work, hand out Card Set C. Students will now be challenged to draw two different representations of each number. Do not take up the previous sets of cards. Students may use these for guidance in making their decisions.

### **Taking two class periods to complete all activities**

If you have to divide the lesson into two class periods, you may want to have a way for students to save the work they have done with the place card sets. You may have each pair tape the cards down with on their place cards. You may choose to have them do this even if you are not dividing up the class period just to use as a visual during the class discussion.

### **Sharing Work (10 minutes)**

When students get as far as they can with matching the card sets, allow partners to compare their matches to other pairs. Students are permitted to ask questions and make changes to their original work.

### **Extension activities**

Extension 1: Challenge those students who complete Card Set C to go back and add a third representation of the number.

Extension 2: Provide the students with Card Set D and let them explore representations in the thousands.

### **Whole-class discussion (10 minutes)**

Give each student a mini whiteboard, marker, and eraser.

Conclude the lesson by discussing and generalizing what has been learned. The generalization involves first extending what has been learned to new examples, and then examining some of the conclusions students came up with. Allow pairs to bring up some of their work samples and share their thinking.

Ask students:

- *Why did you decide to place that card there?*
- *What clues did you use to help you in your decision?*
- *Is there another card that could go there?*
- *Challenge students to build the number \_\_\_\_\_ on their whiteboard in different ways.*

### **Improving individual solutions to the assessment task (10 minutes)**

Give the students a new copy of the original task, **teacher says:** *Think about what you have learned during this lesson. Using what you have learned try to improve your work.*

To focus your students, refer to the common issues chart. Use the questions which reflect the greatest need(s) of your students. You may choose to write some questions on the board, state them out loud with the whole group and ask questions of individuals as you move around the room, or working with small groups.

Resource:

Arrow Cards are from the [Kentucky Center for Mathematics](#)

Lesson adapted from: *Uncovering Student Thinking in Mathematics Grades K-5: 25 Formative Assessment Probes for the Elementary Classroom*, Tobey and Minton, Corwin Press, 2011.

The whole class introduction was created in collaboration with Kentucky Center of Mathematics.

This lesson format was designed from the Classroom Challenge Lessons intended for students in grades 6 through 12 from the [Math Assessment Project](#).

# 243

Circle ***all*** the true statements about this number and explain your thinking.

A) 2 tens and 43 ones

B) 243 ones

C) 2 hundreds 403 ones

D) 24 tens and 3 ones

E) 2 hundreds and 43 ones

F) 1 hundred and 143 ones



# Circle all representations of 315.

The image is divided into four quadrants, each containing visual representations of numbers:

- Top-Left Quadrant:** A large box contains 10 ten-frames (each with 10 dots). To its right are 5 individual dots, a group of 10 dots, a group of 20 dots, a group of 30 dots, a group of 40 dots, a group of 50 dots, a group of 60 dots, a group of 70 dots, a group of 80 dots, a group of 90 dots, and a group of 100 dots.
- Top-Right Quadrant:** A box contains 10 ten-frames. To its right are 2 groups of 10 dots and 5 individual dots.
- Bottom-Left Quadrant:** A box contains 10 ten-frames. To its right is a box containing 10 ten-frames, a group of 10 dots, and 5 individual dots.
- Bottom-Right Quadrant:** A box contains 10 ten-frames. To its right are 3 groups of 10 dots and a box containing 10 ten-frames.

Which of these does NOT belong?

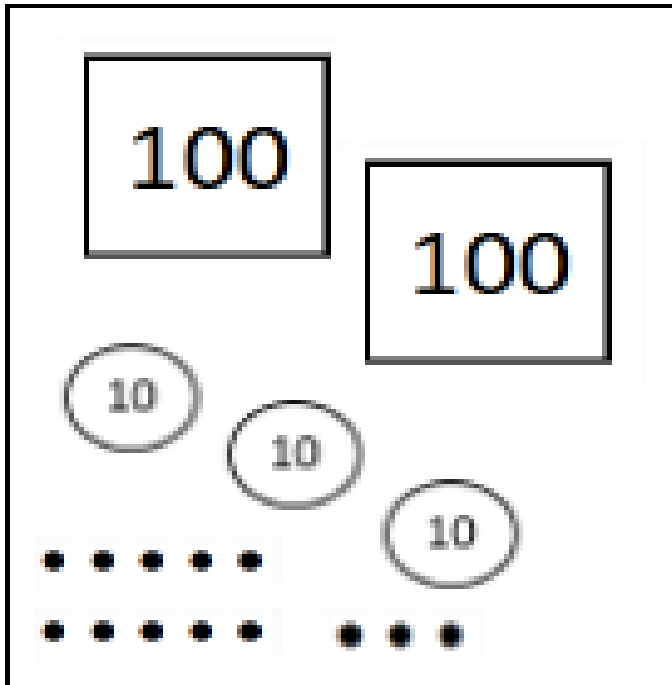
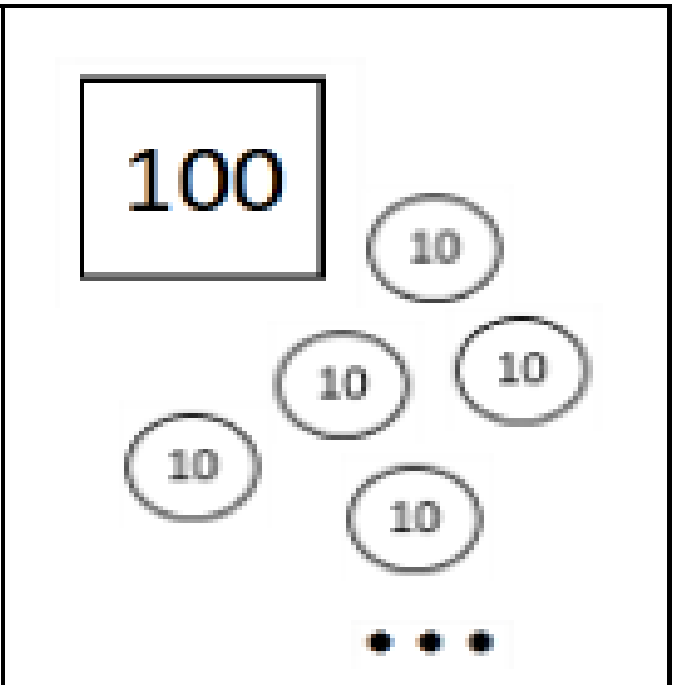
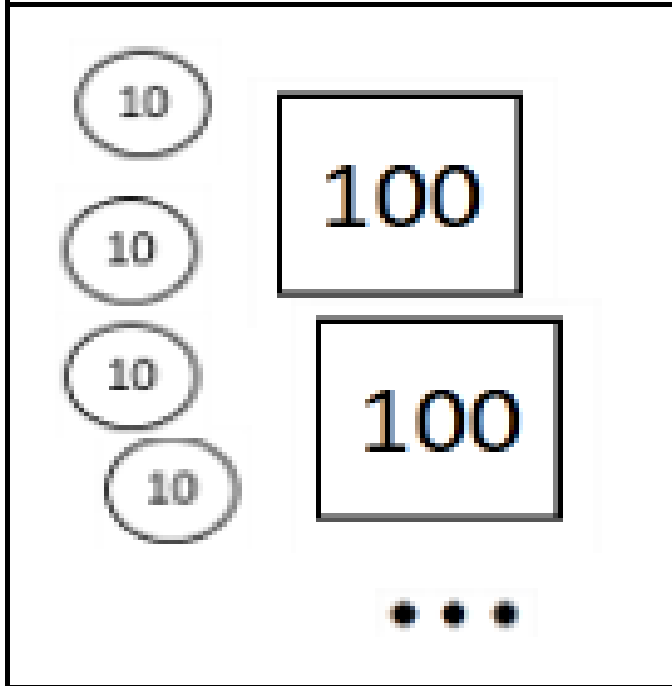
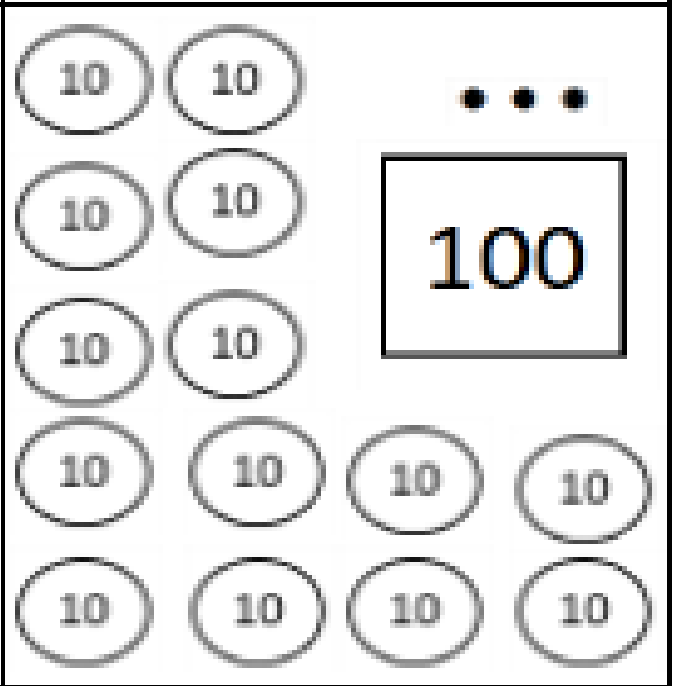
 <p>Panel 1: A 100 block, another 100 block, three 10 blocks, and two groups of five dots.</p>	 <p>Panel 2: A 100 block, five 10 blocks, and three dots.</p>
 <p>Panel 3: Four 10 blocks, two 100 blocks, and three dots.</p>	 <p>Panel 4: Ten 10 blocks, one 100 block, and three dots.</p>

Card Set A

347

Card Set A

254

Card Set A

136

Card Set A

477

Card Set A

Card Set B

502

Card Set B

482

Card Set B

337

Card Set B

357

Card Set B

Card Set A

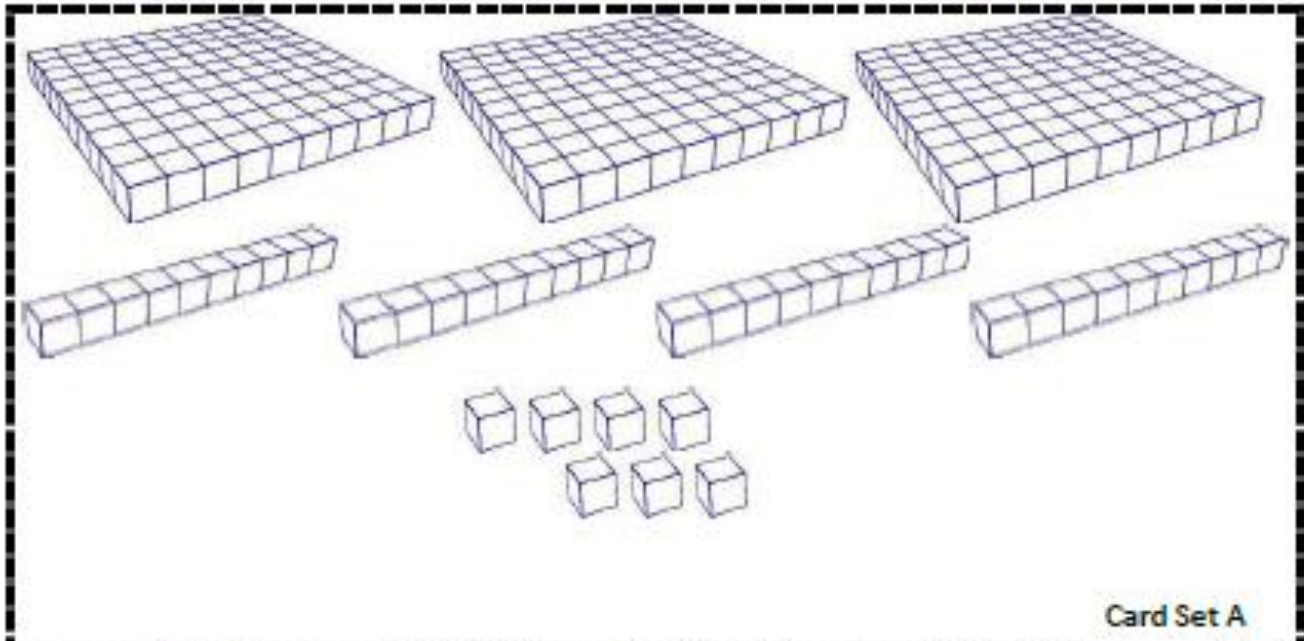

Card Set A

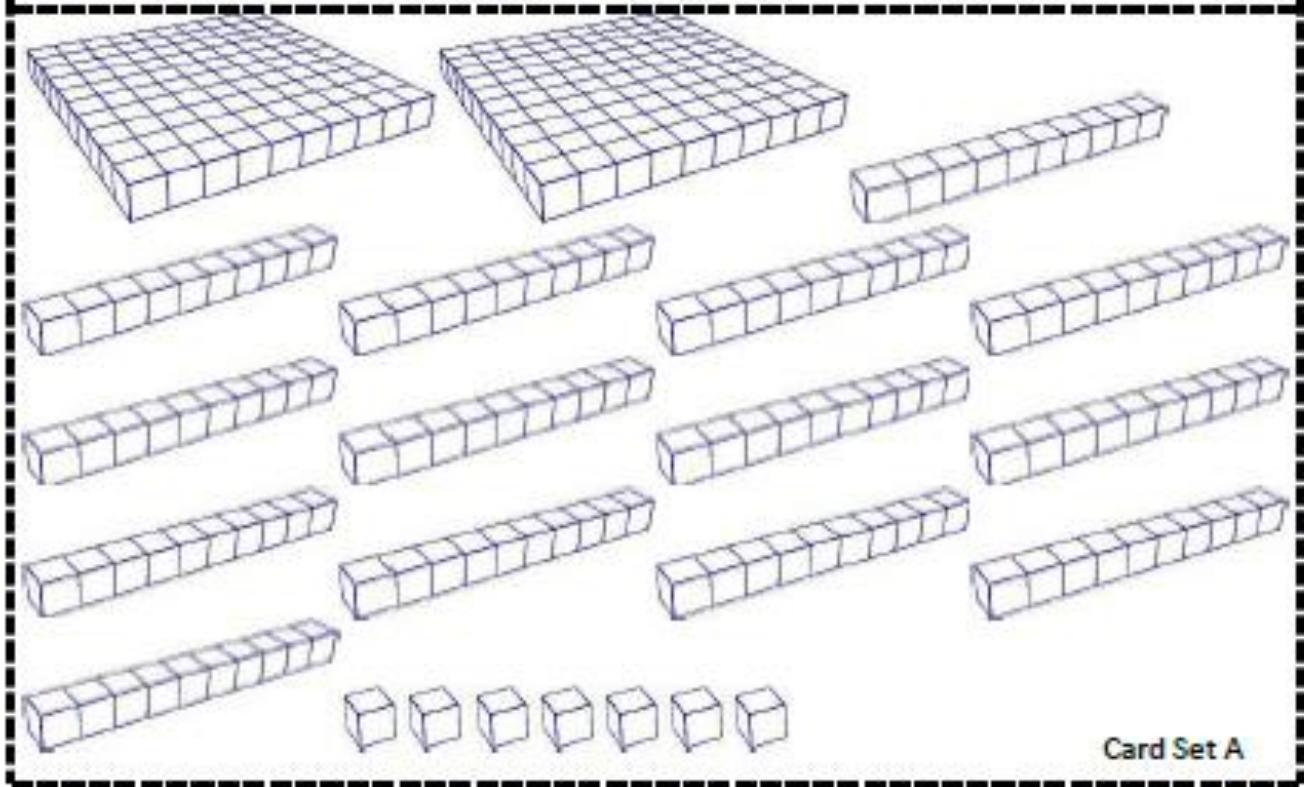

Card Set A

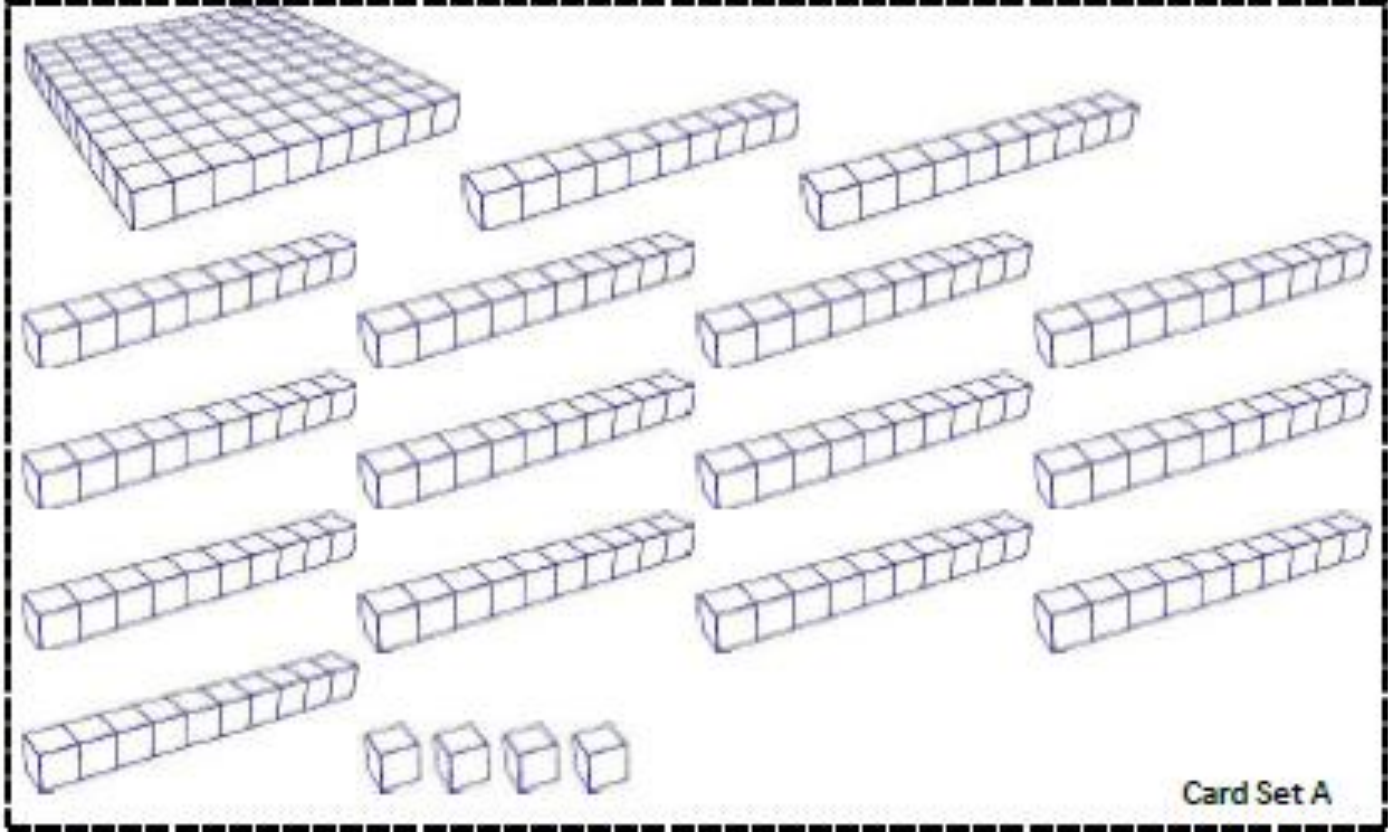
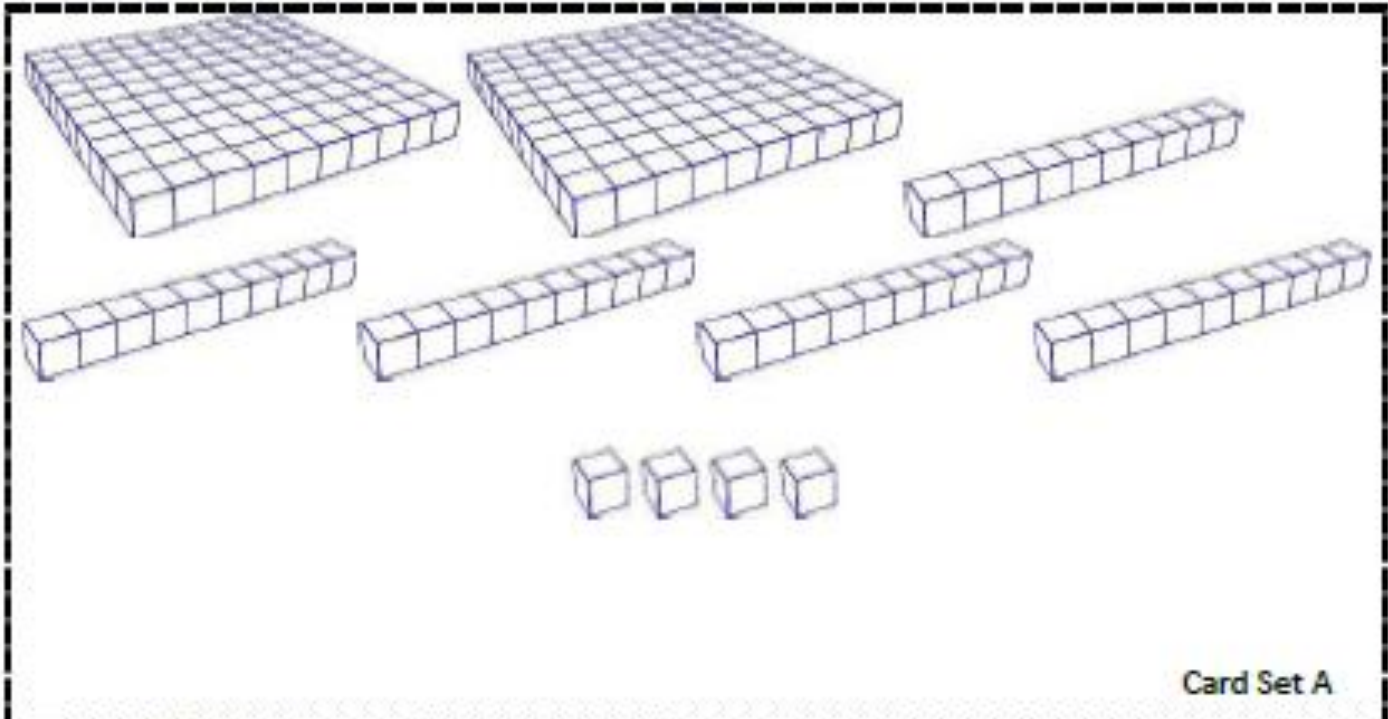

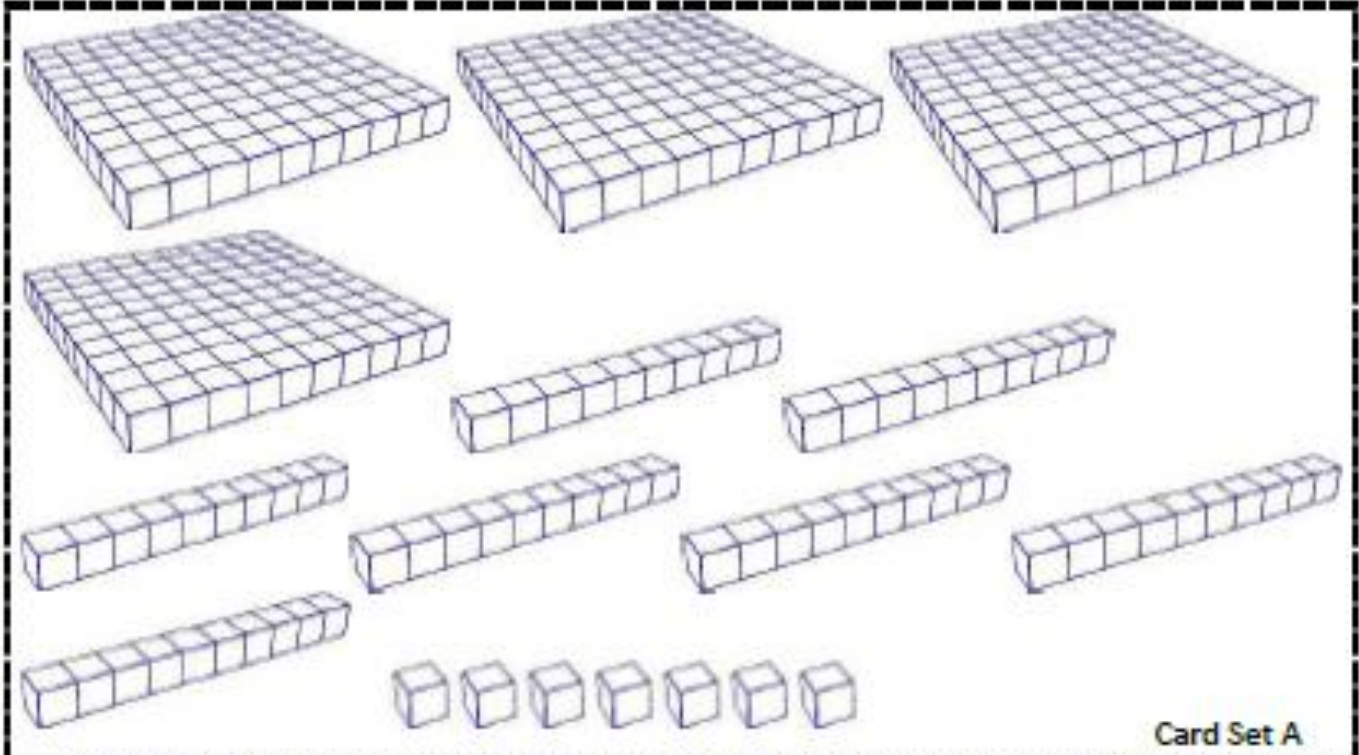

Card Set A

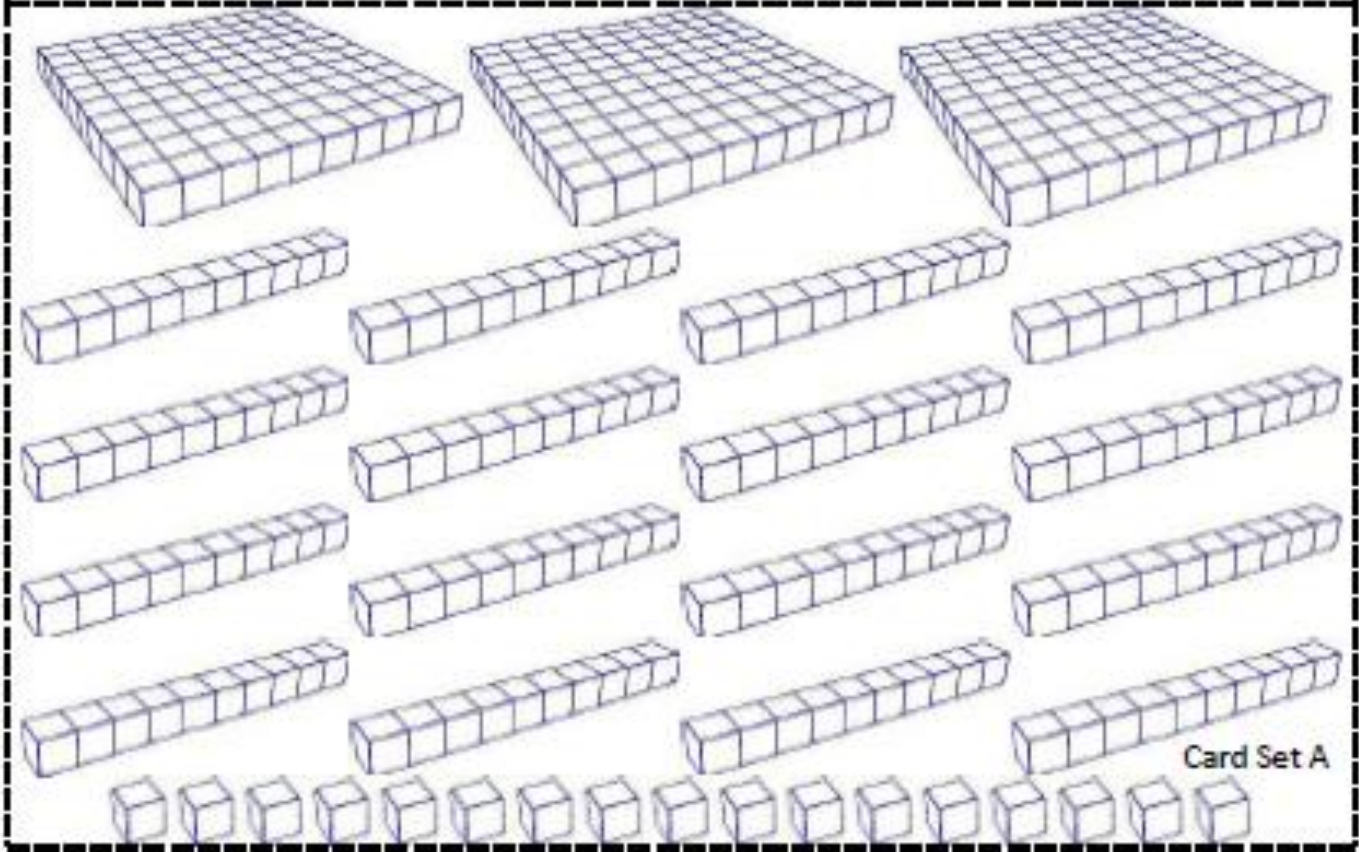

Card Set A

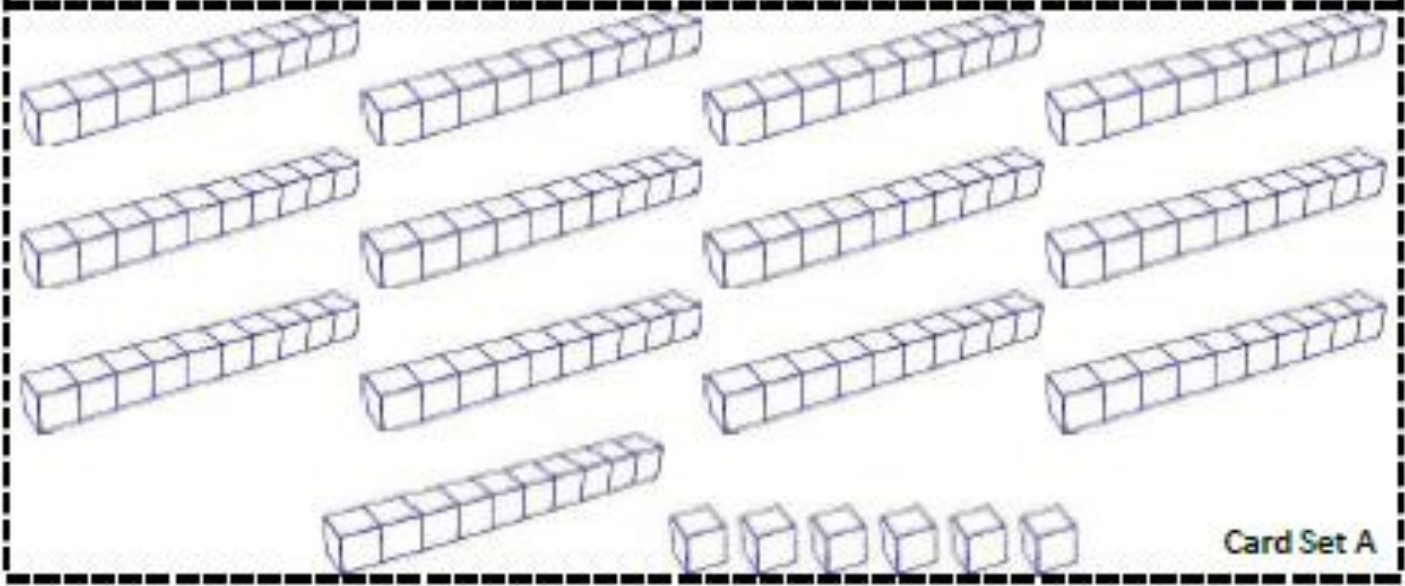
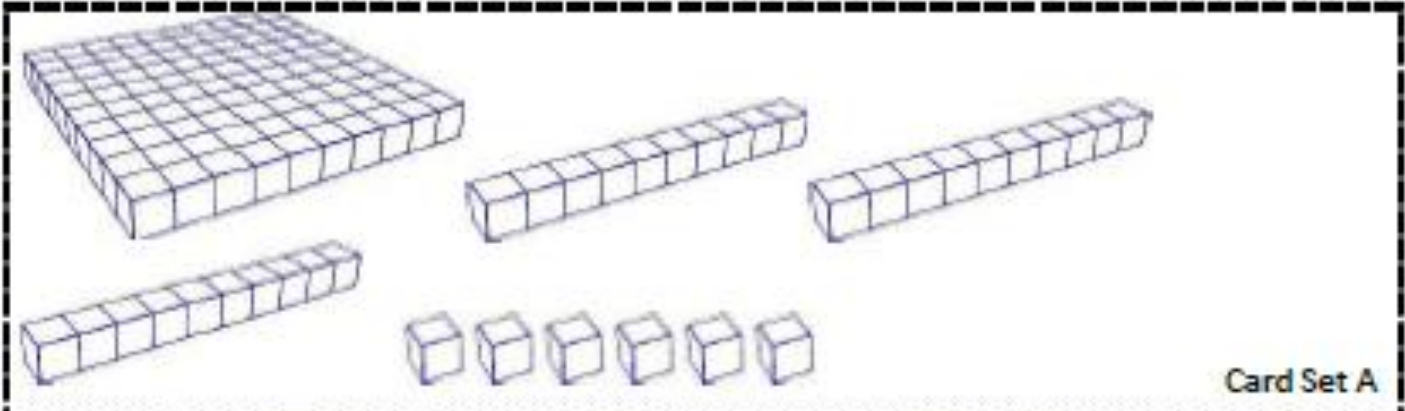

# Card Set B

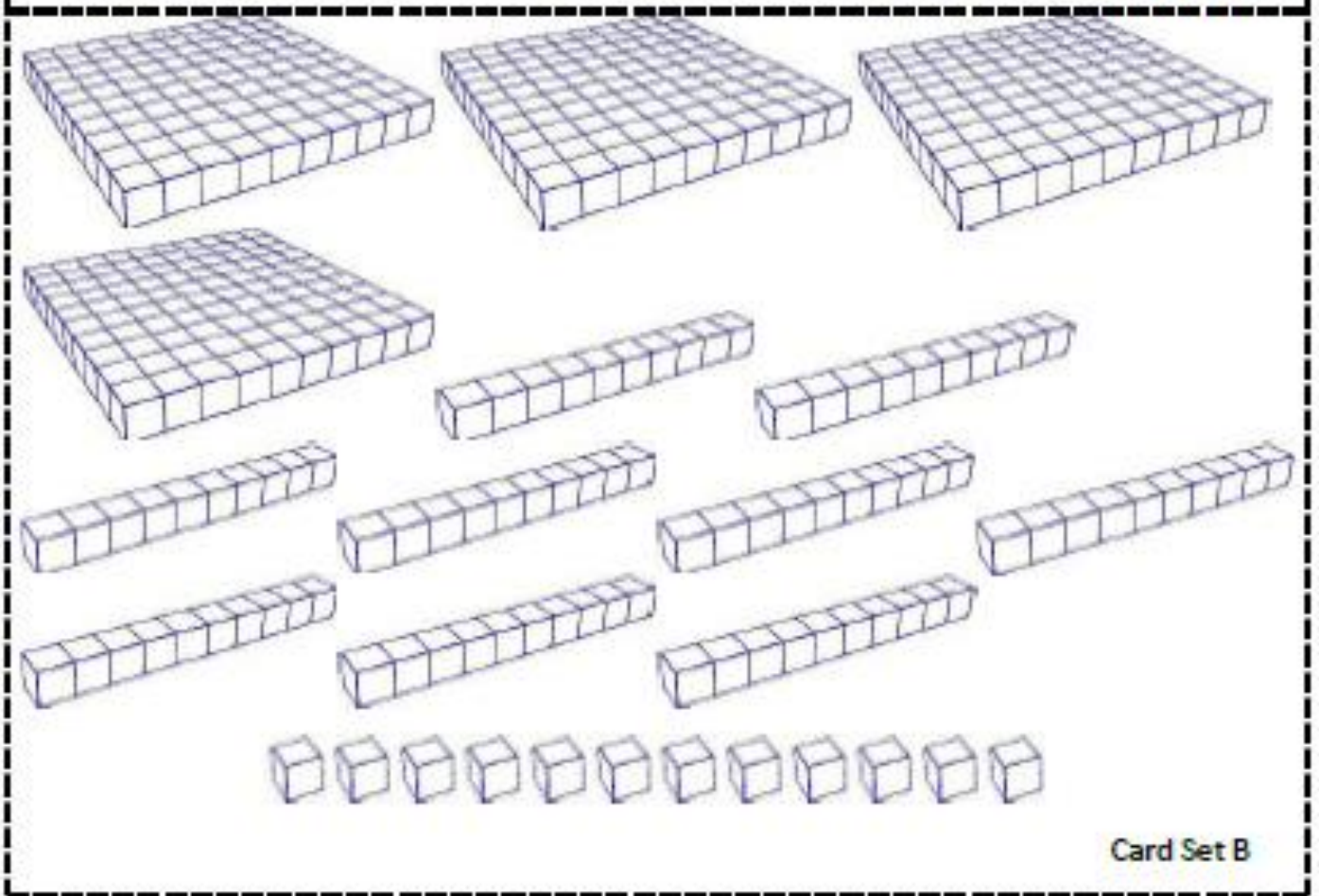
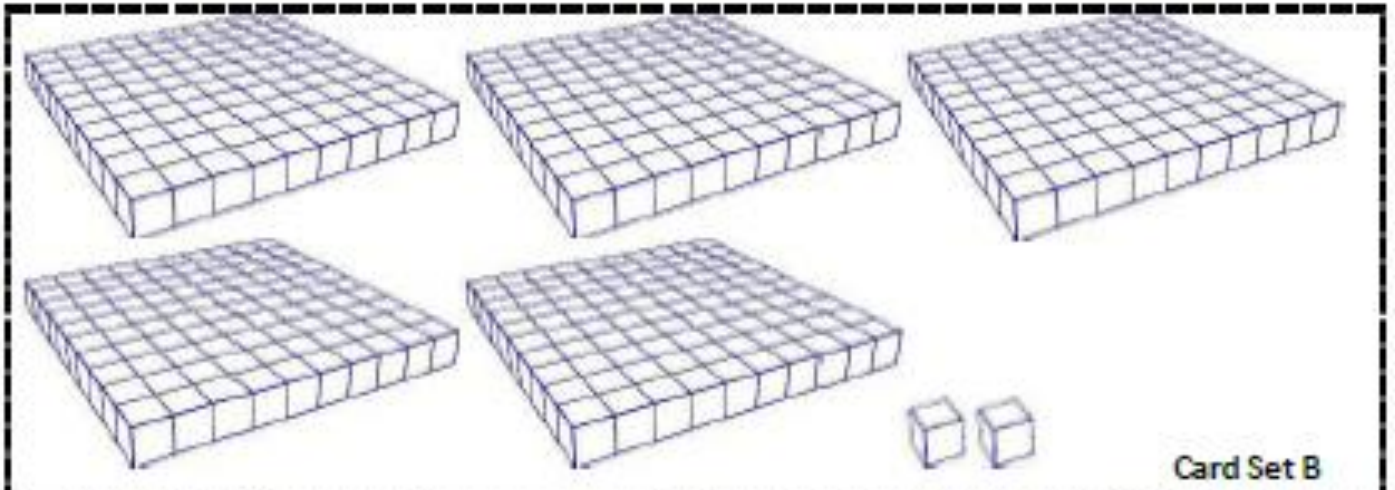



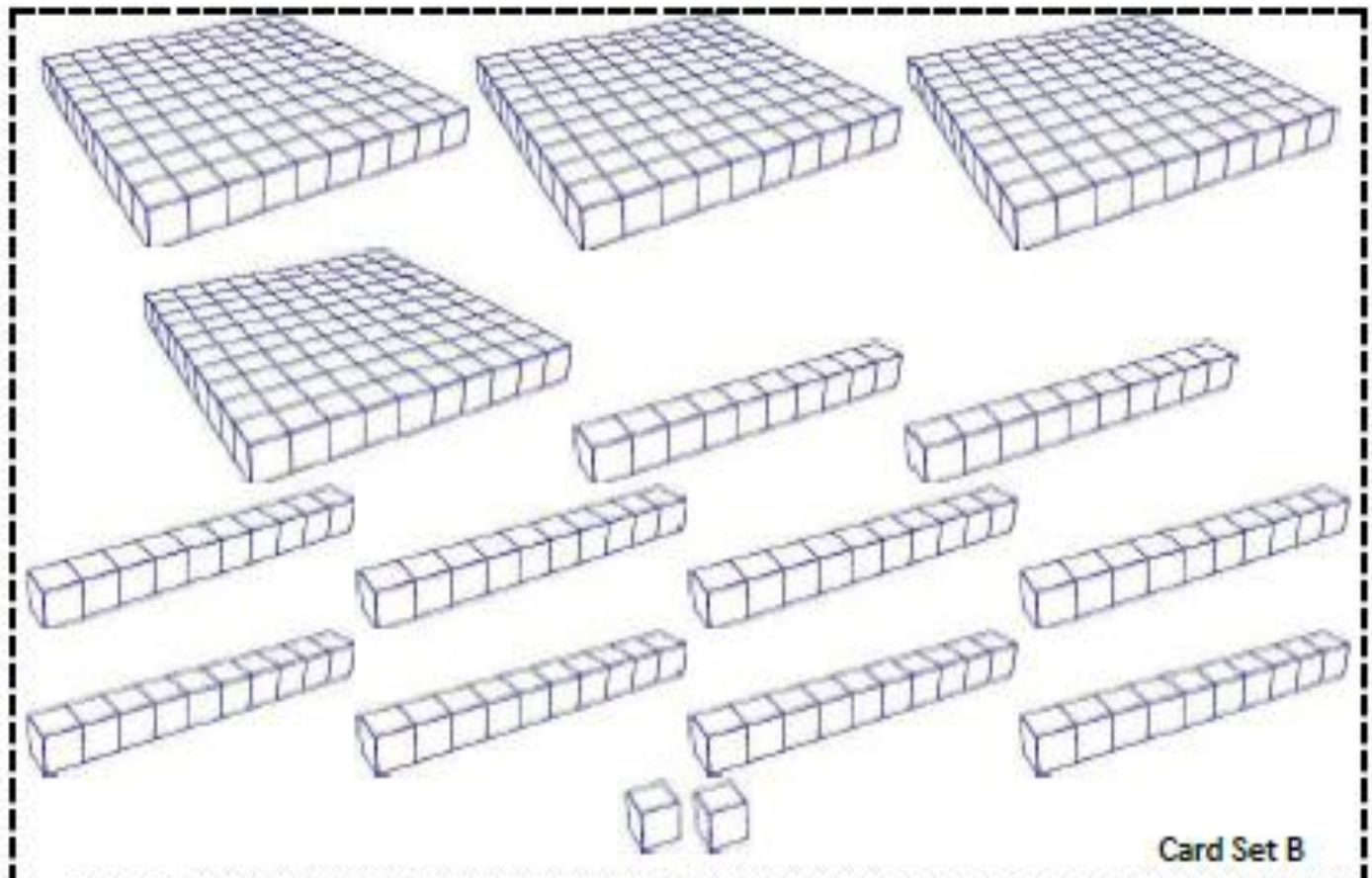

Card Set B

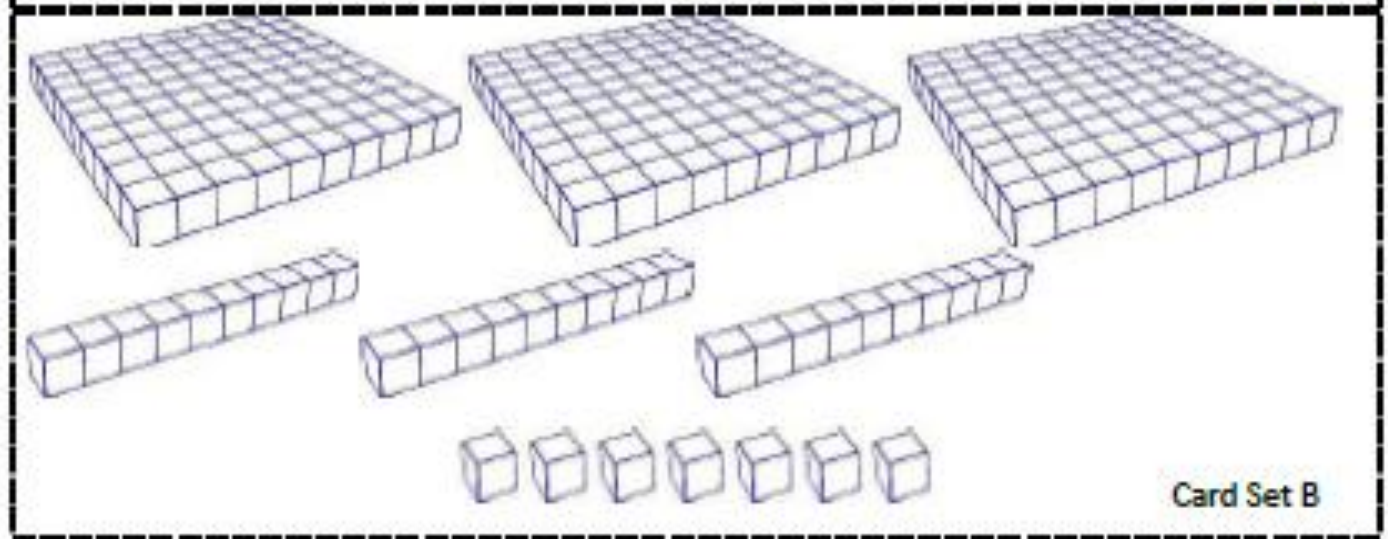

Card Set B

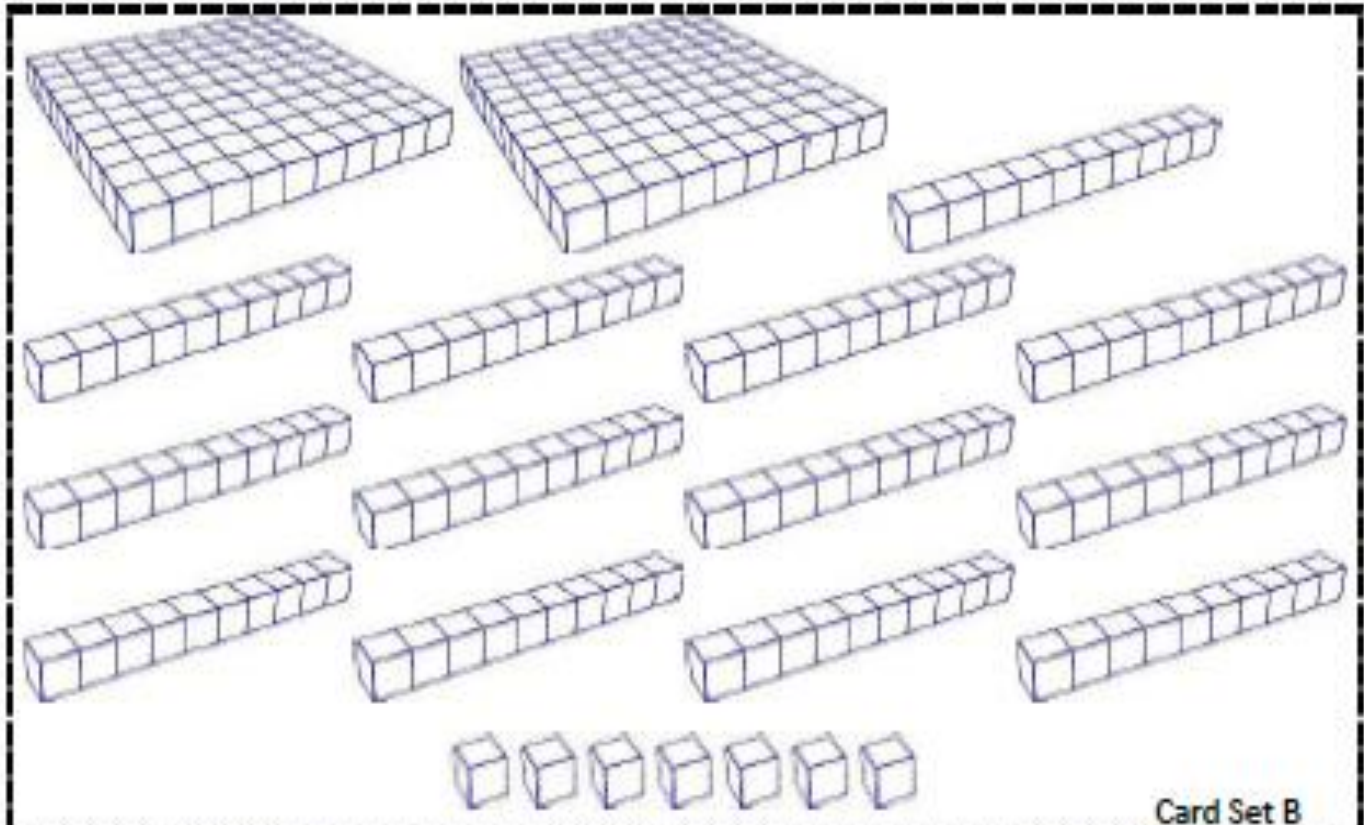

Card Set B

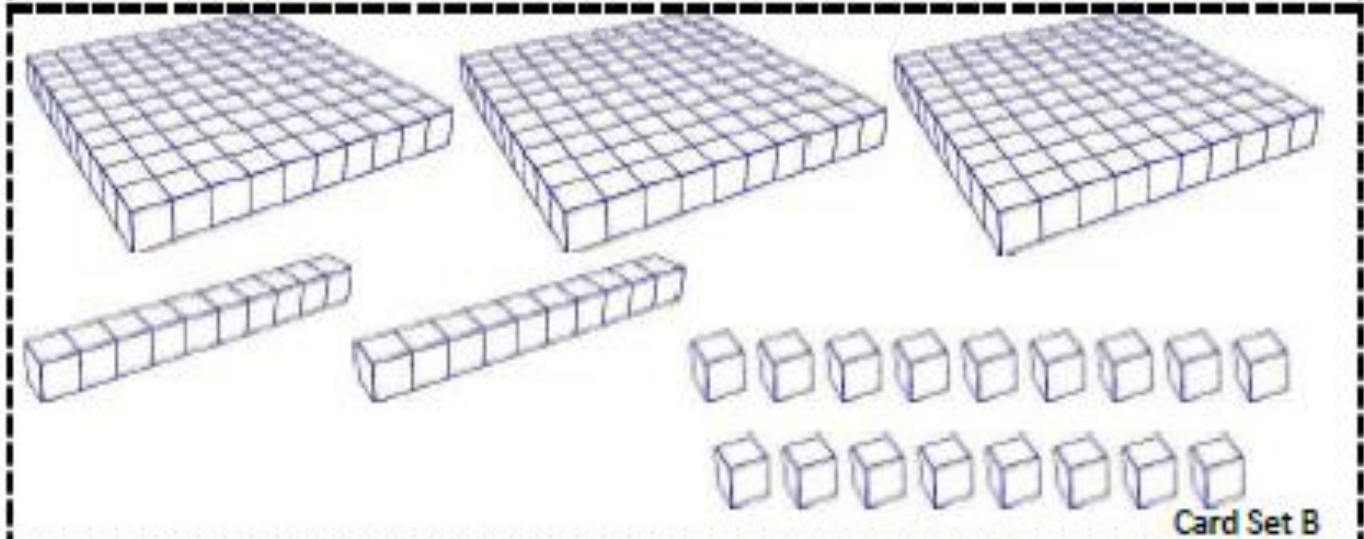

Card Set B

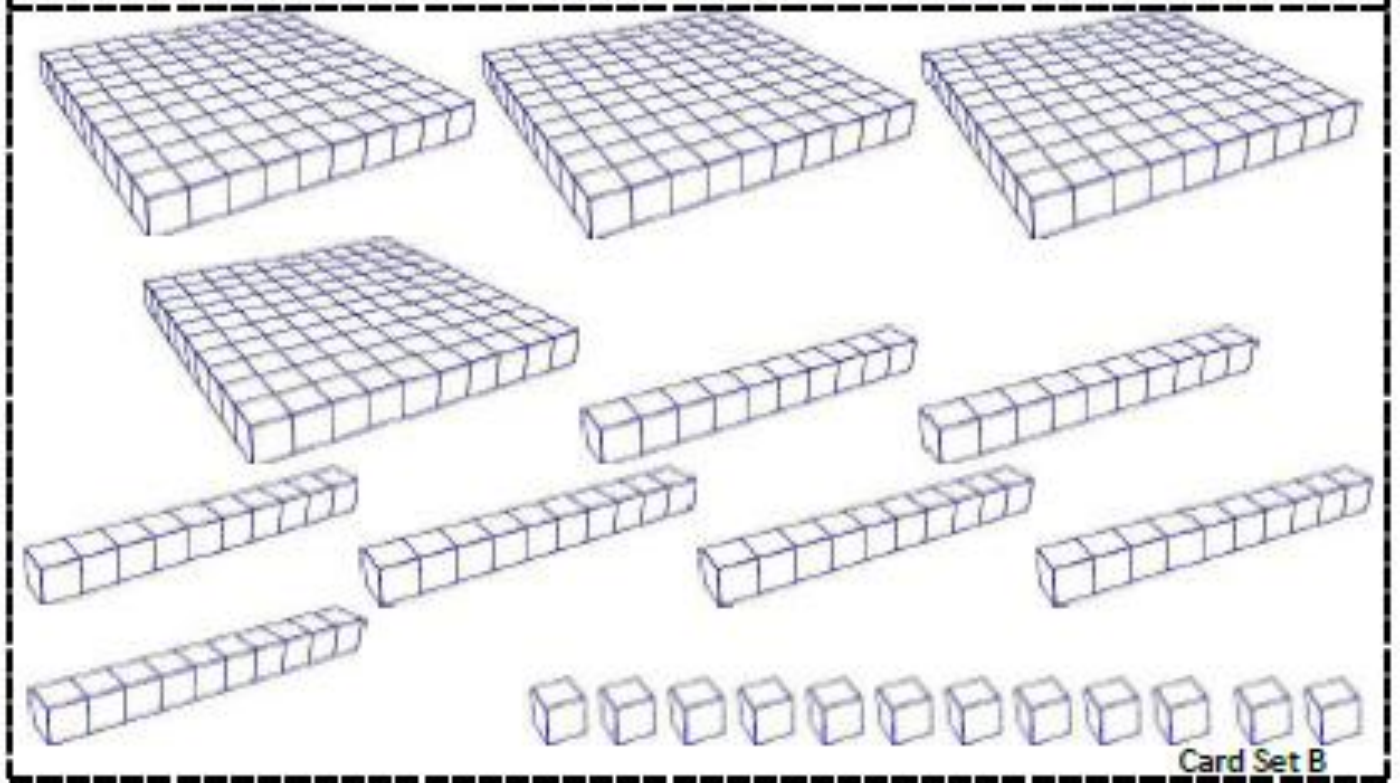
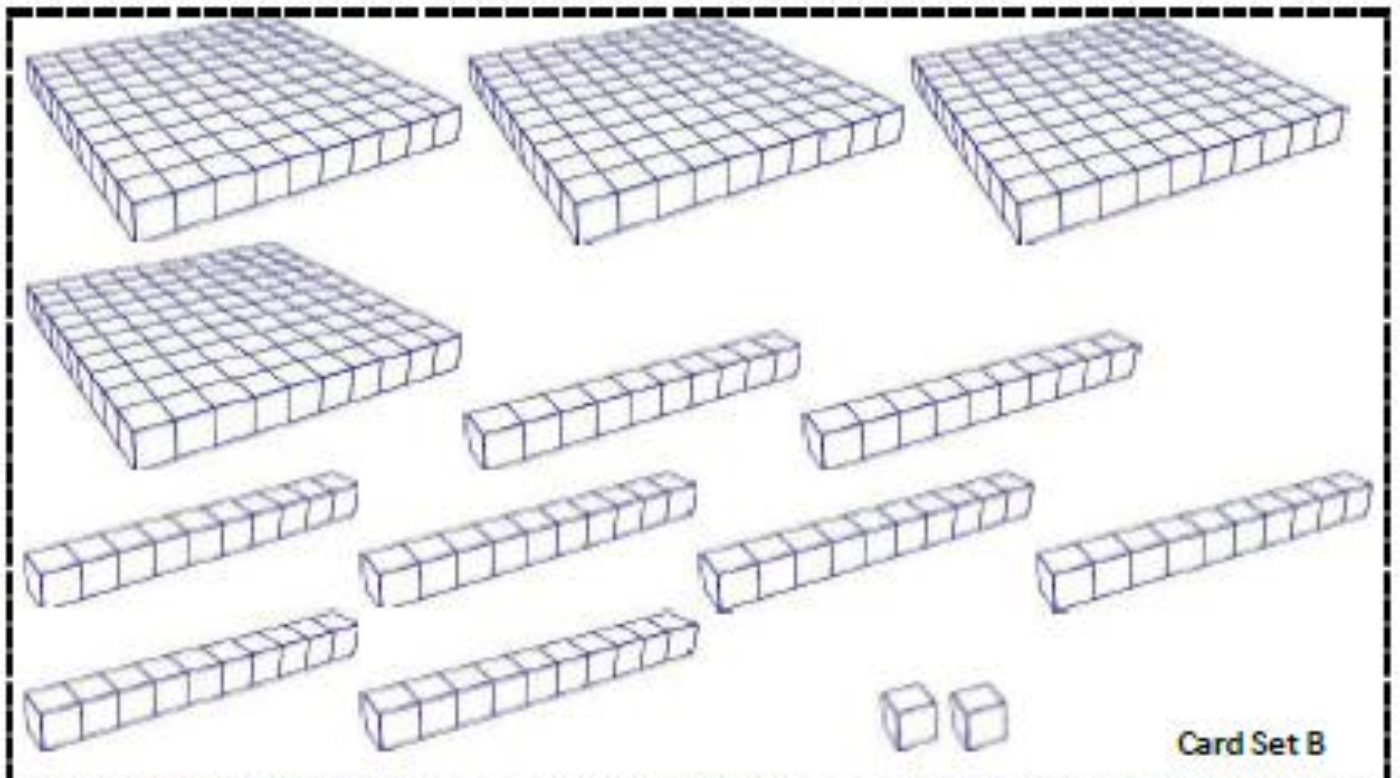

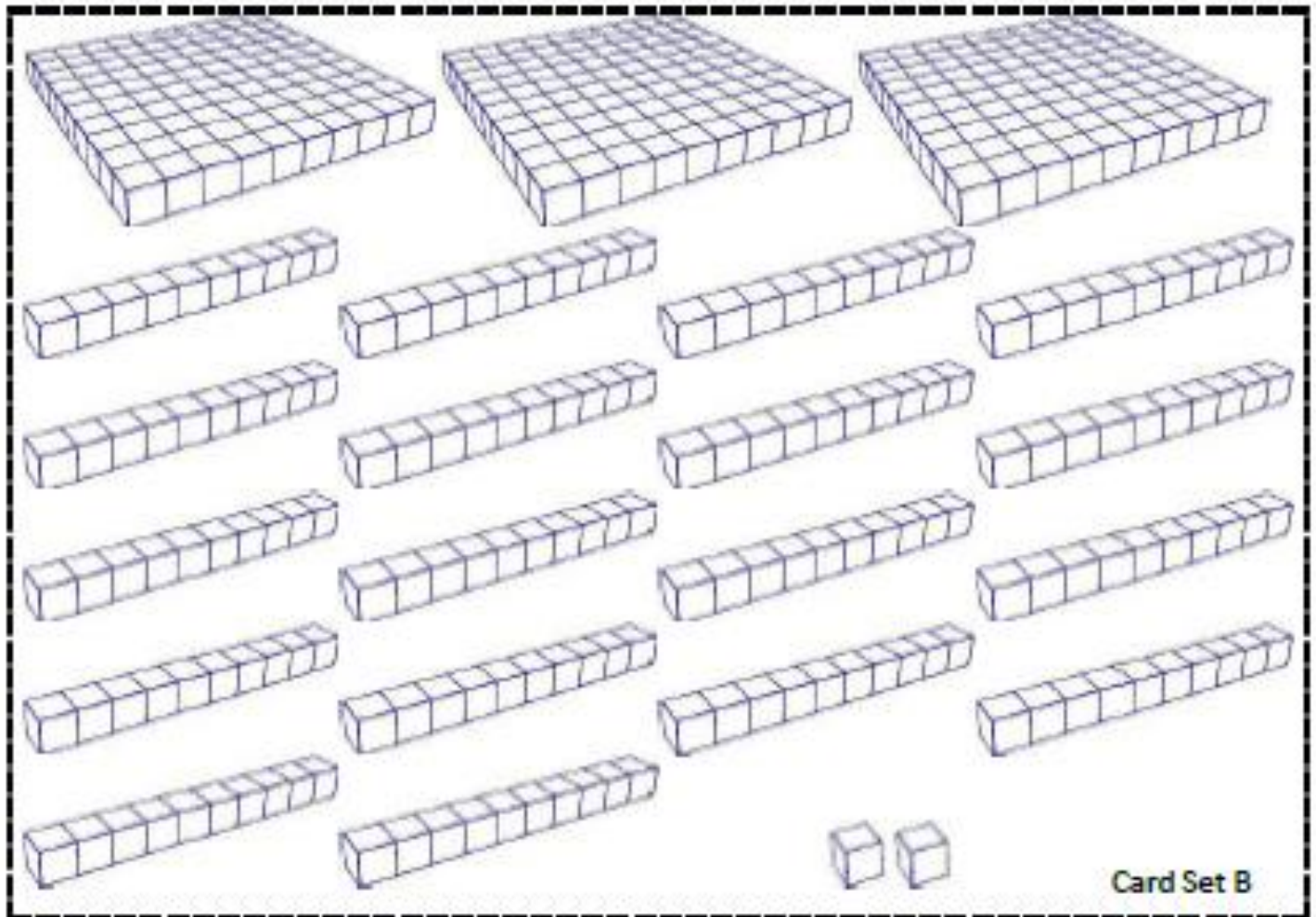

Card Set B

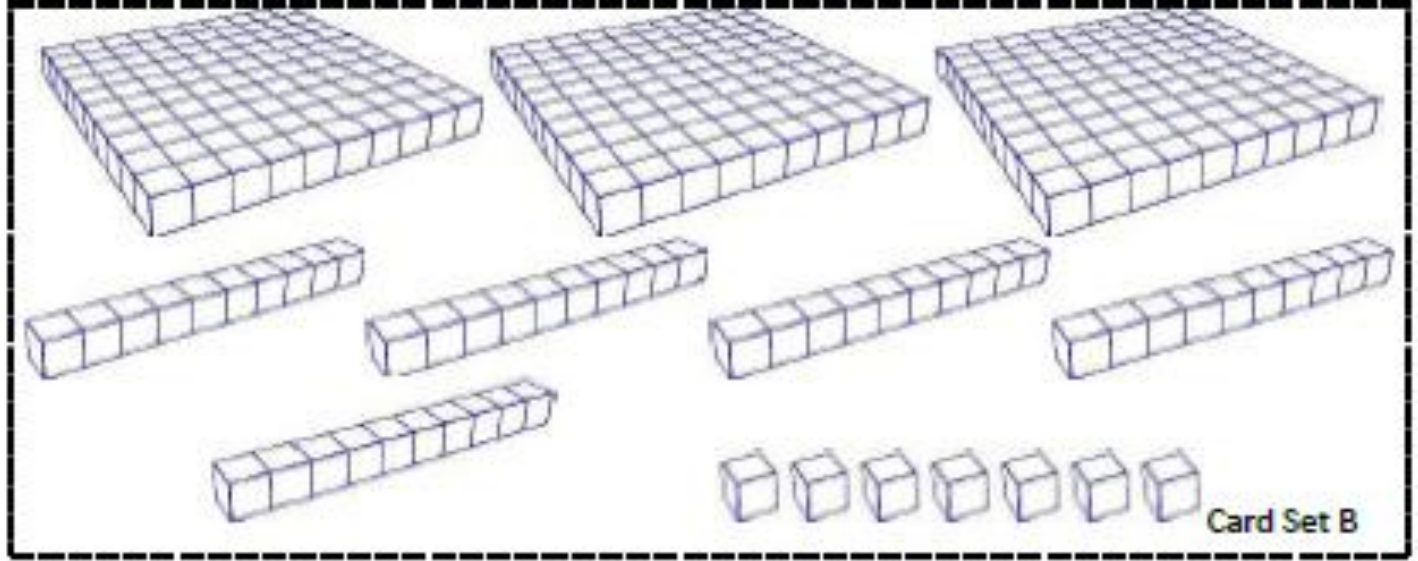

Card Set B

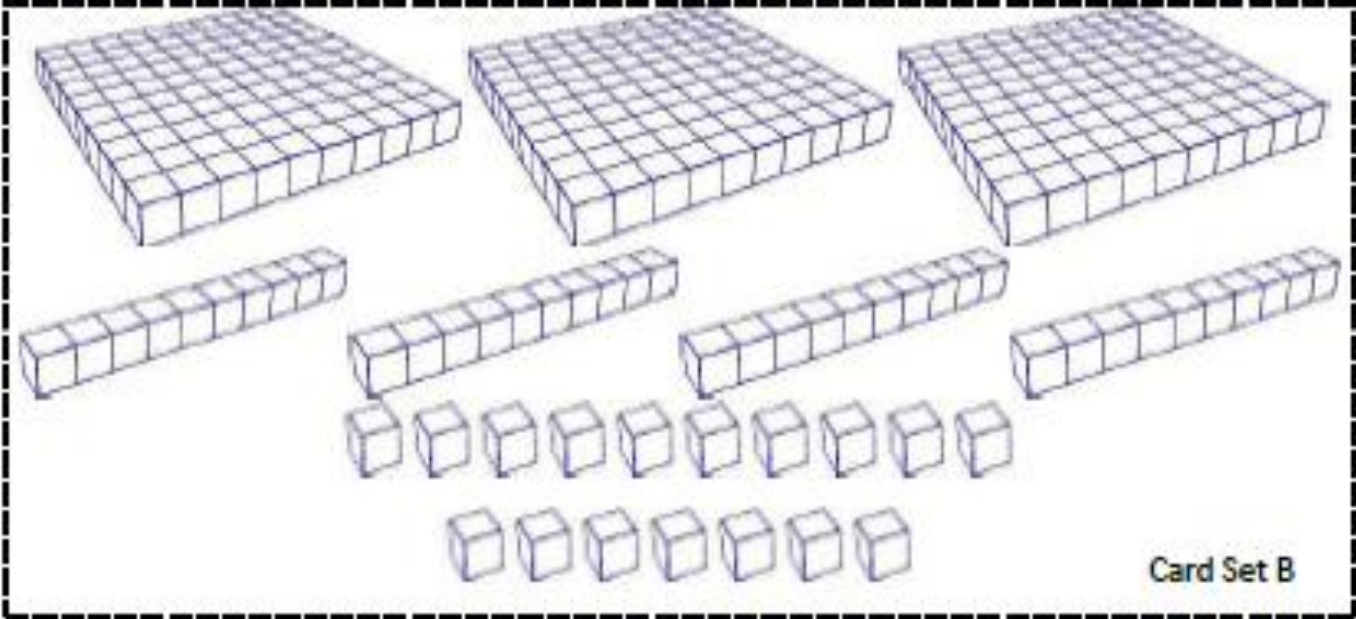
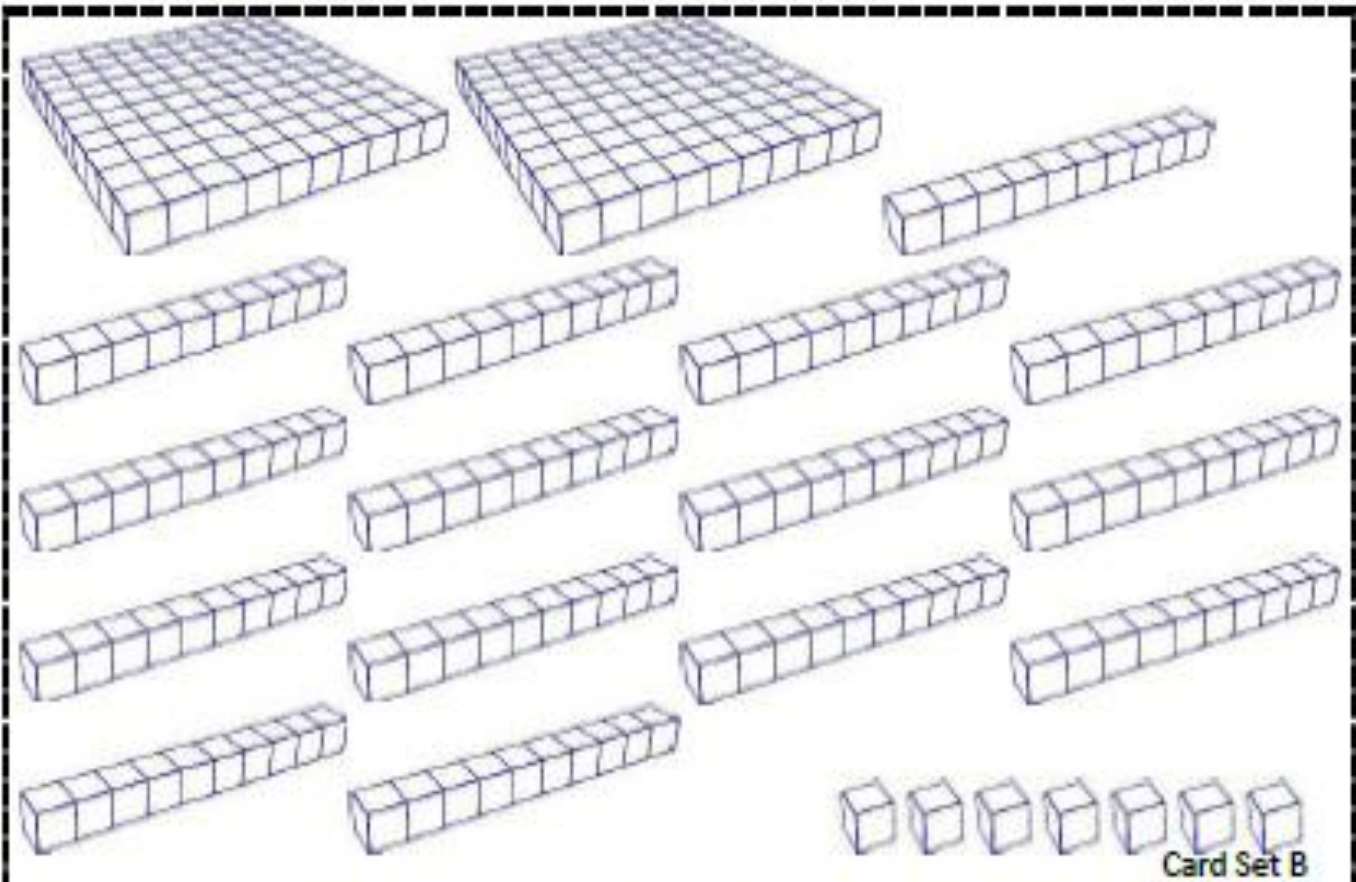

Card Set C

547

Card Set C

547

Card Set C

338

Card Set C

338

Card Set C

630

Card Set C

630

Card Set C



421

Card Set C

421

Card Set C

### **Extension #1**

*Students will return to card set C and will be asked to draw each number a third way.*

### **Extension #2**

*Build the following numbers using base ten blocks.*

4390

5912

7310

6934

2902

9022